

# D45 SYSTEM

System technical guide

TECHNICAL GUIDE 2011



Release 01 – September 2011

**bticino**



**INDEX****D45 VIDEO DOOR ENTRY SYSTEM**

General features and devices overview . . . . .	02
Installation rules. . . . .	73
Configuration concept and examples . . . . .	95
Troubleshooting. . . . .	124
System topology - layout examples . . . . .	127
Wiring diagrams. . . . .	137

## D45 System introduction

D45 VDE system consists of five main components: Entrance Panels, Internal Units (Handsets), Switchboard, system accessories, and Power Supply . It is a security monitoring system that applies MCU, serial connection BUS, TCP/IP LAN technologies. The system is designed to perform functions like call, doorbell, conversation, monitoring, door lock release, network, alarm, and message, by connecting riser systems with network system devices, and using the main Switchboard as the management and control centre for the whole system.

- Main feature of the D45 system: the use of CAT5 cables for the whole system, ensuring easy installation, and cost savings;
- Audio and video signals are transmitted differently, with better performance in terms of electronic disturbance immunity,
- The system automatically equalizes and amplifies the video signal, restoring high quality video performance even for long distances using CAT 5 cable,
- Smart system power supply, all system devices detect the power load status automatically, and work in normal power mode, therefore saving power;
- Embedded operation system, combined with advanced display mode, improves the operation efficiency and display quality of the Switchboard;
- The system can satisfy different size requirements, based on riser, building, district, or TCP/IP network, ensuring the most economical system project;
- Without video amplifier on the line, B/W video signals can reach 2 km distance. Colour video signals can reach 1km distance;
- The System supports 2 management centre levels, district management centre and system management centre;



## Products list and main features

TYPE	MODEL NAME	CODE NUMBER	FIXING WAY	DIMENSIONS (mm)	CURRENT ABSORPTION	
					STANDBY	WORK
ENTRANCE PANELS	DIGITAL COLOUR ENTRAL PANEL	322010	Embedded	325*125*60.5 mm	30 V/110 mA	30 V/290 mA
	SMALL COLOUR ENTRANCE PANEL	322020	Wall mount	141*108*31 mm	/0 mA	12 V/250 mA
HANDSETS	COLOUR HANDSFREE 5.6"	321010	Wall mount	139.5*193.5*29 mm	30 V/10 mA	30 V/140 mA
	HANDSET B/W	321030	Wall mount	220*202*56 mm	30 V/20 mA	30 V/320 mA
	HANDSFREE B/W	321020	Wall mount	220*208*56 mm	30 V/20 mA	30 V/320 mA
	AUDIO HANDSET	322040	Wall mount	141*91*34 mm	30 V/30 mA	30 V/70 mA
	COLOUR HANDSFREE 7"	322050	Wall mount	175*260*23 mm	30 V/20 mA	30 V/145 mA
ACCESSORIES	FLOOR SHUNT	323002	DIN Rail	72*105*33 mm	30 V/25 mA	30 V/130 mA
	RISER SHUNT	323003	DIN Rail	106*105*33 mm	30 V/60 mA	30 V/110 mA
	2 BRANCHES VIDEO SPLITTER	323007	DIN Rail	72*105*33 mm	30 V/2.5 mA	30 V/70 mA
	ENTRANCE PANEL VIDEO MIXER	323004	DIN Rail	72*105*33 mm	30 V/20 mA	30 V/60 mA
	DISTRICIT GENERATOR	323013	DIN Rail	175*105*66 mm	30 V/100 mA	30 V/300 mA
	SYSTEM EXP INTERFACE	323019	DIN Rail	106*105*33 mm	30 V/50 mA	30 V/80 mA
	BASIC APARTMENT INTERFACE	323008	DIN Rail	72*105*33 mm	30 V/40 mA	30 V/140 mA
	POWER SUPPLY	323005	Wall mount	167.5*161*85 mm	AC input 220 V	DC output: 30 V/2 A
	AUXILIARY POWER SUPPLY	323010	Wall mount	167.5*161*85 mm	AC input 220 V	DC output: 30 V/2 A
	APARTMENT INTERFACE	323009	DIN Rail	141*105*33 mm	30 V/40 mA	30 V/140 mA
	D45/2 WIRE INTERFACE	346858	DIN Rail	72*105*33 mm	30 V/1 mA	30 V/20 mA
	D45/IP INTERFACE	323011	DIN Rail	90*175*60 mm	30 V/130 mA	30 V/230 mA
	EP/SWITCHBOARD SHUNT	323018	DIN Rail	72*105*33 mm	30 V/70 mA	30 V/70 mA
	VILLA SHUNT	323016	DIN Rail	72*105*33 mm	30 V/20 mA	30 V/160 mA
	DOOR LOCK ACCESSORY	323015	DIN Rail	72*105*33 mm	30 V/30 mA	30 V/30 mA
	SWITCHBOARD	323001	Table	290*170*165 mm	30 V/160 mA	30 V/280 mA
	CONFIGURATION TOOL WITH SOFTWARE	323020	---	---	---	---
	SF4 SWITCHBOARD SOFTWARE	323012	---	---	---	---

## Entrance panel functions overview

### 322010 - DIGITAL ENTRANCE PANEL COLOUR

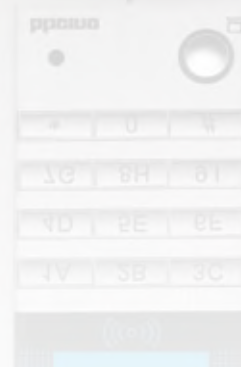
With alloy-die-casting panel with luxurious and elegant appearance. The touchtone keyboard, stable in function, for direct handset call and communication. With a blue night-light display.

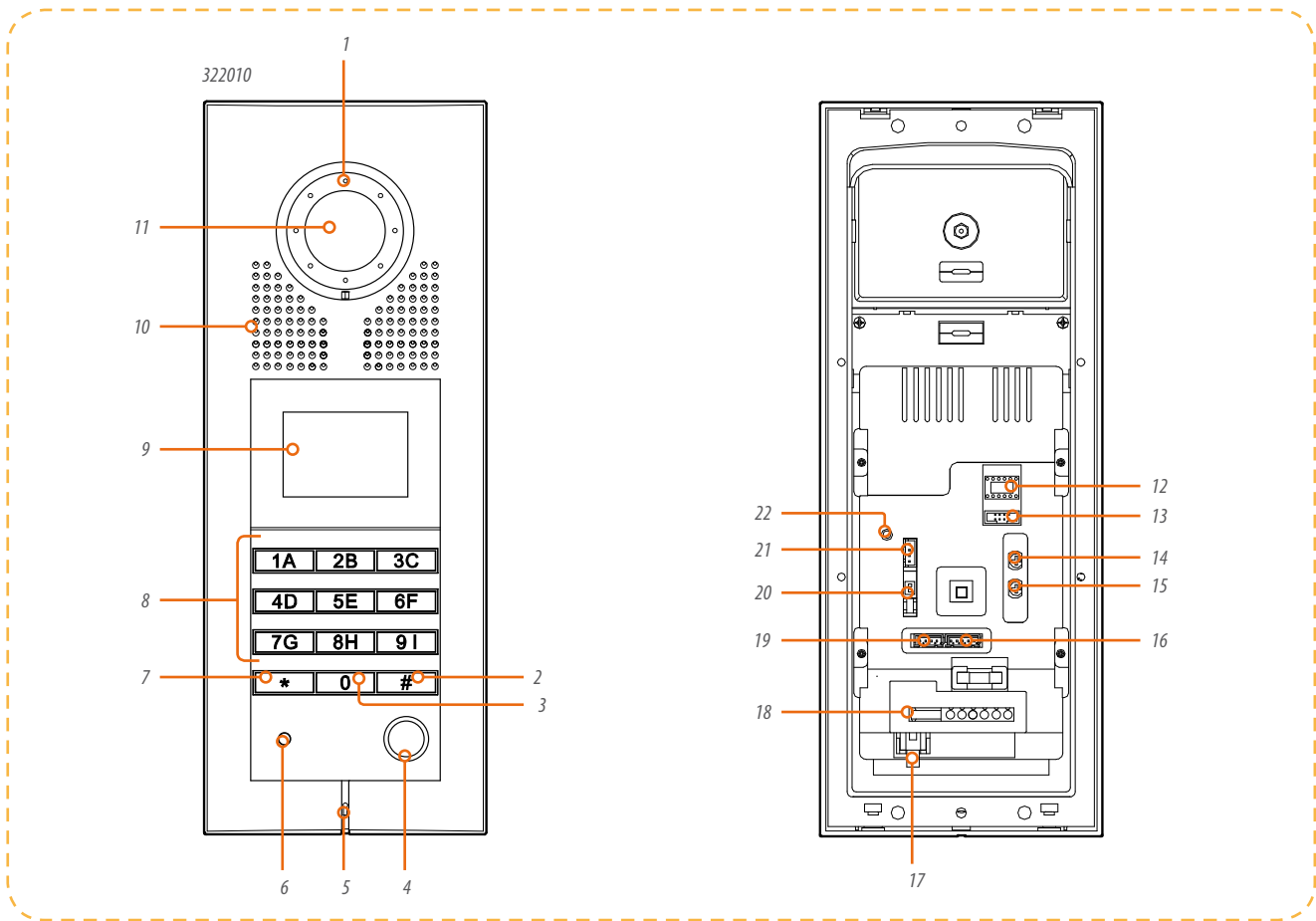
#### FEATURES

Functions such as monitoring, call, conversation, door lock release, etc.

- Volume adjustment;
- Blue backlight and LCD display to guide user operation
- Download the address book;
- The visitor can call the handset and the Switchboard;
- Anti-removal alarm;
- The CCD camera can be adjusted to its optimal effect;
- The software can be updated with no need to open the cover;
- The keyboard is designed with an automatic night lamp;
- It will automatically send an alarm for overtime door opening;
- It can set the video menu;
- CCD Super-brightness LED Light Compensation;
- The parameters of the entry panels can be set;
- Door lock release with password.

*Digital colour EP*





**LEGEND**

- 1. Compensation Lamp
- 2. Confirm menu setting or other operation
- 3. Number keyboard: call the handset and function setting
- 4. Management centre pushbutton: call the Switchboard
- 5. Microphone
- 6. Photosensitive lamp
- 7. Return or quit menu setting
- 8. Alphanumerical pushbuttons
- 9. Access control lens (Optional)
- 10. Loudspeaker
- 11. Camera: to view the image
- 12. NN #FF #II: configurator
- 13. ISP: entrance panel software upgrade connector
- 14. SPK: ADJUST loudspeaker volume
- 15. MIC: ADJUST microphone volume
- 16. VIDEO-IN/GND/NC/+12V/LED-: connect entrance panel camera and compensation Lamp
- 17. SYSTEM BUS uses CAT5 cable to connect to system
- 18. 7P connector  
+12 V/GND: supply power to A/C module  
DOOR LOCK RELEASE: door lock release signal output by A/C module

- GND/DAS: electronic lock status signal connector
- LOCK-/LOCK+: connect electronic lock.
- 19. SPK-OUT/GND/GND/SPK-OUT: connect entrance panel loudspeaker
- 20. V-GAIN: video gain setting
- 21. ANT: connector for A/C module antenna
- 22. RESET: for password reset

**ENTRANCE PANEL PARAMETER CONFIGURATION**

Entrance panel parameters setting by configurator. After changing the parameters the Configurator must be switched off and on again.

⊙	⊙	⊙	⊙	⊙	⊙
N	N	#F	#F	#I	#I
⊙	⊙	⊙	⊙	⊙	⊙

- NN: Entrance panel address
- # FF: Floor quantity in a riser
- # II: Maximum internal unit (apartments) for each floor in the same riser

## Entrance panel functions overview

### 322010 DIGITAL EP CALL BY THE VISITORS

1. A visitor can input the resident's number as per the prompt on the display and press the # key for confirmation. The unit shall send out the call signal, displaying the message "calling, please wait" . It can establish two-way communication and at the same time transmit the image to the handset. Now the resident can open the lock by pressing the door lock release key on the handset. While waiting or during the conversation, the visitor can hang up the phone by pressing the \* key, terminating the call.
2. When necessary, the visitor or the resident can directly press the Switchboard button to call and talk with the Switchboard for help.

### Handset monitors and entrance panels:

When the entrance panel is idle, the resident can press the Monitor button of the handset to monitor the entrance panel and see the image. Press the UNLOCK button to release the door lock of the entrance panel or the Talk button to a talk. When several entrance panels are installed on the same riser (The address must be kept in sequence, like 01, 02, 03 and so on. And the address for the first entrance panel must be set as 01), you can press on the Monitor button of the handset to cycle through other entrance panels.



**CALL TRANSFER**

In case that the entry panel is used as (Riser EP or secondary EP), visitors or residents can call the Switchboard from the entrance panel and ask to be put through to a certain handset. The Switchboard will then call the handset and after hanging up, direct communication between the entrance panel and the handset will be established.

**OPEN THE LOCKS BY PASSWORD**

As per the prompt on the display, we can input the unlock password after pressing on the # key. By pressing the same key again, the electric lock will be opened automatically. If the password input is not correct, the display will show "wrong password" and return to idle after three short beeps. Now press on the # key and re-input the password.

*Note: If the unlock function is disabled, it will fail. When starting this function, therefore refer to the setting.*

**ALARM FOR OVERTIME DOOR OPENING**

When the lock-status signal type has been correctly set, and the riser door is open for over 120 seconds, the corresponding entrance panel will send an alarm to the Switchboard.

*Note: This function requires that the electric door lock on the entrance panel is fitted with a lock-status (open and close) signal output, and it will only work when the lock-status signal is connected to the DAS in the 7P wiring port behind the entrance panel.*

**ALARM FOR THE DISTRESS CODE**

When the six-digit user password is entered for unlocking, and if the user re-enter the distress code "5" and presses the key for confirmation, then the entry panel shall send the distress code alarm to the Switchboard while it opens the lock.

Recover the master password:

When the entrance panel is at standby, press the reset switch at the back of the entrance panel for more than 5 seconds. A long beep will be heard and the password will be reset to 200000.



## Entrance panel functions overview

### 322010 DIGITAL EP SET THE FUNCTIONS

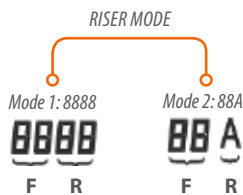
Press the # key for about 5 seconds. Input the master password as per the prompt on the display and press the # key for confirmation. When you get to the setting status, you can enter the following settings as per the prompt: (Press on the 0 key to scroll through the pages).

1. Select 1 and change the master password. The default master password is 200000. If you want to change it, you can input your desired password as per the prompt and press the # key for confirmation. If two inputs are identical, then the master password is successfully changed. If not, it will indicate an error and ask you to re-enter it. Note that only the administrator is entitled to keep or modify the master password.
2. Select 2 to set the signal types to open/close electric door locks. As per the interface prompt, we can press the 0 or 1 key to set as either often-closed or often-opened type.
3. Select 3 to complete the setting of the anti-removal alarm.

This function must be used together with the anti-removal alarm pushbutton. By selecting this function and pressing the anti-removal alarm button the entrance panel automatically send a removal alarm. If a wrong alarm is sent due to A wrong settings during installation, switch the power off and press the alarm button. Then switch the power on again to cancel the alarm settings. When the entrance panel has been installed, reopen the anti-removal alarm function.

4. Select 4 to complete the mode setting of the room number.

Eight options are available for your selections. When using the entrance panel as the (Riser EP or secondary EP), the first and the second mode can be selected. When using it as the (Backbone EP or main EP), the 3rd, 4th 5th, 6th, 7th and 8th mode can be selected, depending on the actual situations. The default factory setting is the 1st mode.

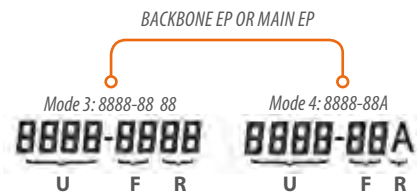


**Mode 1: 8888**  
 88 Floor number  
 88 Room number

**Mode 2: 88A**  
 88 Floor number  
 A Room number

When used as (Backbone EP or main EP):

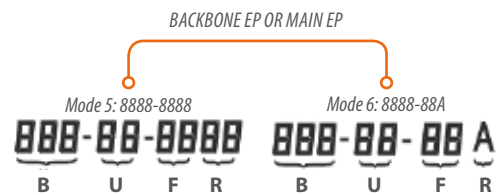
**Mode 3 and Mode 4:** these are commonly used modes. When the riser number (building number and unit number) plus floor number plus room number is not above 8 digits, one of them can be selected. Now the riser number actually includes the building number. Take Unit 1 of Building 1 for example, the riser number will be 0101.



**Mode 3: 8888-8888**  
 8888 Unit number  
 88 Floor number  
 88 Room number

**Mode 4: 8888-88A**  
 8888 Unit number  
 88 Floor number  
 A Room number

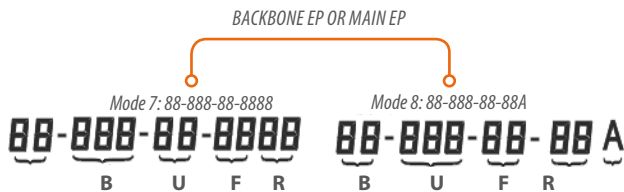
**Mode 5 and Mode 6:** When the building number plus unit number (building number and unit number are coded separately) plus floor number plus room number is not above 9 digits, one of them can be selected. Take Room 1 5th floor, Unit 2 of Building 101 for example, the riser number will be 101-02-0501.



**Mode 5: 888-88-8888**  
 888 Building number  
 88 Unit number  
 88 Floor number  
 88 Room number

**Mode 6: 888-88-88A**  
 888 Building number  
 88 Unit number  
 88 Floor number  
 A Room number

**Mode 7 and Mode 8:** When there are several zones in one project and we need the zone number for a call, we can select one of them. Take Room 1 5/F Unit 2 Building 101 of Zone 2 for example, which can be coded at 02-101-02-0501.



**Mode 7: 88-888-88-8888**

- 88 Zone number
- 888 Building number
- 88 Unit number
- 88 Floor number
- 88 Room number

**Mode 8: 88-888-88-88A**

- 88 Zone number
- 888 Building number
- 88 Unit number
- 88 Floor number
- A Room number

5. Select 5 to complete the settings of the configuration parameters of the entrance panel.

As per the prompt on the display interface, we can set the address of the entrance panel, the floor number of the said riser and the maximum number of handset installed on each floor of the riser. We can also set the address of the gate in relation to the Switchboard. When we come to the setting interface, the configuration parameters of the current entrance panel will appear. To make changes, enter the desired number in serial order. After entering the 8 digit number, just press # to confirm.

*Note: This setting is only valid when the entrance panel does not use the parameter of the configurator. For example, a certain place has been configured of its resistance, and this setting shall be invalid.*

6. Select 6 to setup language: you can setup english or other languages.
7. Select 7 to setup pulse width for unlock. 1 to 99 seconds can be set for lock opening pulse.
8. Select 8 to set the password door lock release function. As per the prompt on the display, we can enable or disable the function to open the door lock by password. When we disable this function, the menu item "7 to edit the lock-open password" shall not be on display, and therefore cannot be edited.

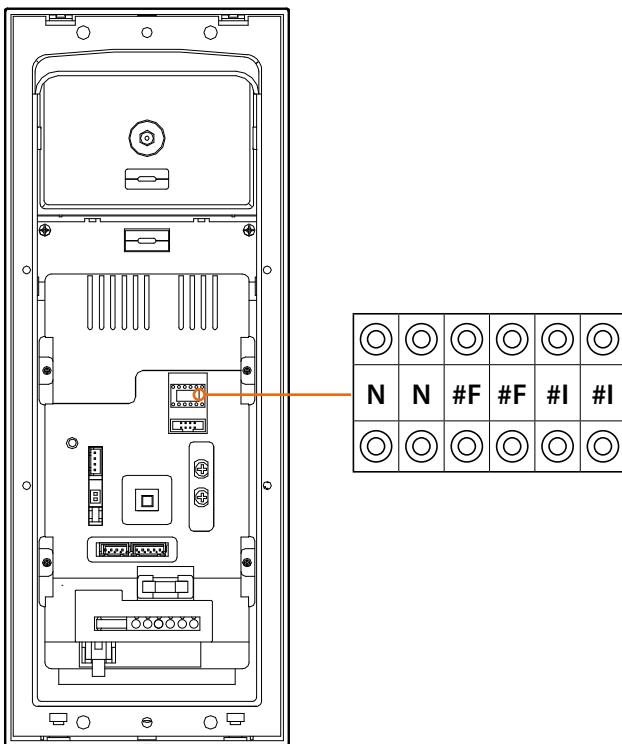
9. Select 9 to complete the relevant settings of the password door lock release function. There are three available options:
  - Set the door lock release password. Press the 1 key and enter your desired group number and the password. On entering the group number, if password of the group already exist, it will be replaced by the new one. Press \* key to exit and return to the last operation.
  - Delete the door lock release passwords one by one. Press the 2 key and enter the group number you want to delete. Press the # key to delete the password.
  - Delete all the door lock release passwords. Press the 3 key and a prompt window will appear asking you if you want to delete all the door lock release passwords or not. Press the \* key to exit and the # key to delete all the passwords.

## Entrance panel functions overview

### CONFIGURE THE EP PARAMETERS

The configuration parameters for the EP can be set either through Item 5 in the function settings under the LCD interface, or by means of the configurator. The latter is of high priority, but it will need repowering each time the resistance is replaced, as can be shown in the following diagram:

NN refers to the EP address, #FF refers to the floor number and #II refers to the maximum number of rooms in each floor.



N (Tens Place)	N (Units Place)	#F (Tens Place)	#F (Units place)	#I (Tens Place)	#I (Units Place)
-------------------	--------------------	--------------------	---------------------	--------------------	---------------------

#### Photosensitive function

When natural light falls below a certain degree, the stand-by light compensation LED tube will come on to compensate for the light. So even in dim light, users will be able to perform the necessary. With the light compensation function the visitors can be identified at a distance of up to 400 mm.

#### Volume adjustment

MIC: to adjust the output level of the microphone.

SPK: to adjust the volume of the speakers.

When used as (Backbone EP or main EP), it can download the address book using the computer.

Online update of programs

It can download or update the software through the ISP port, no need to open the cover.

Points to consider when adjusting the camera:

When adjusting the head up or down, the angle can't be too wide, or vignetting may occur.

Points to consider when installing the electric door lock release of the entrance panel:

The electric door lock released controlled directly by the entrance panel is a positive door lock release powered at DC 12 V, with a control power source of ≤1 A. For other lock types, door lock release item 323015 must be used.

- Adjust the volume of the loudspeakers
- Adjust the volume of the microphone
- Anti-removal alarm open & close function
- Camera Socket
- Adjustment switch for video gains and to adjust the video signals up and down
- Setting pushbutton
- Signal interface of door lock status
- Connect the power or the door lock release
- EP address configurator
- Connect with CAT5 cable line to the system

The entrance panel has two video compensation gears. By setting the different V-GAIN gears, we can adapt the video signal output from the entrance panel to the different transmission distances. Directions for the setting: On for moving up and Off for moving down.



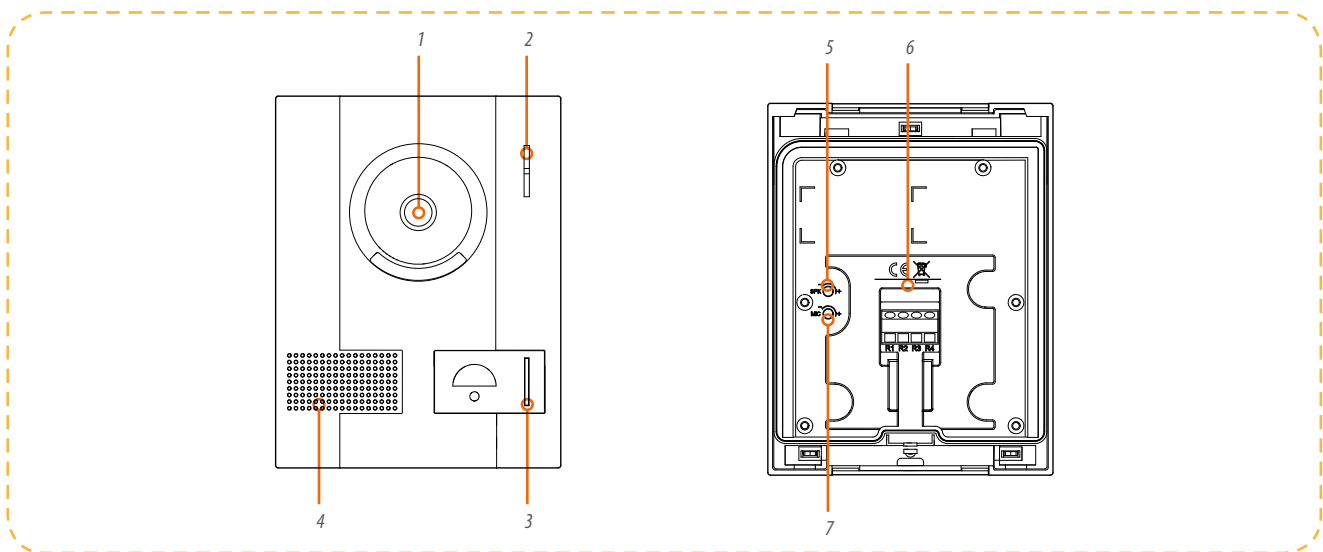
DIP SWITCH SETTING INSTRUCTION FOR B/W AND COLOUR INSTALLATION	Distance	1	2
	0 – 300 m	OFF	OFF
	300 – 700 m	ON	OFF
	700 – 1000 m	ON	ON

The data given for the settings in the above table is only for reference. In actual situations, some deviation may occur. Therefore, we need to adjust the settings according to the actual image requirements during installation.

**322020 SMALL EP**

Independent video door phone set, which should be installed by the apartment door. Aluminium alloy panel brings luxury and a classic look; touch tone pushbuttons with stable performance; for calling and communicating directly with handsets. Colour camera.

*Small colour entrance panel*



**LEGEND**

- 1. Camera
- 2. Microphone
- 3. Call key
- 4. Loudspeaker
- 5. SPK: to adjust the volume of sound coming from the handset to this device
- 6. R1: to connect the R1 terminal of the handset  
R2: to connect the R2 terminal of the handset  
R3: to connect the R3 terminal of the handset  
R4: to connect the R4 terminal of the handset
- 7. MIC: to adjust the volume of sound coming going this device to the handset

**INSTRUCTIONS**

- 1. Press "call", the handset will ring and display the picture through the camera of this device. Pick up the receiver of the handset, to start conversation.
- 2. SPK and MIC adjustments at the back of the Small EP could be used to adjust the volume of this device and the handset.
- 3. Small EP cannot be installed with the camera directly facing the sun.

## Indoor handset functions overview

*Colour handsfree 7" alarm  
322050*



*Colour handsfree 5.6" alarm 321010*



*Handsfree B/W  
321020*



*Handset B/W  
321030*



### VIDEO HANDSETS FUNCTIONS

322050 colour alarm handsets can be linked with D45 series of entrance panels into the unit bus system. Through the Switchboard, it is also possible to link the unit bus system to the district bus system, thus realizing such management functions as conversation and monitoring among the resident handset, the riser door entrance panel and the Switchboard.

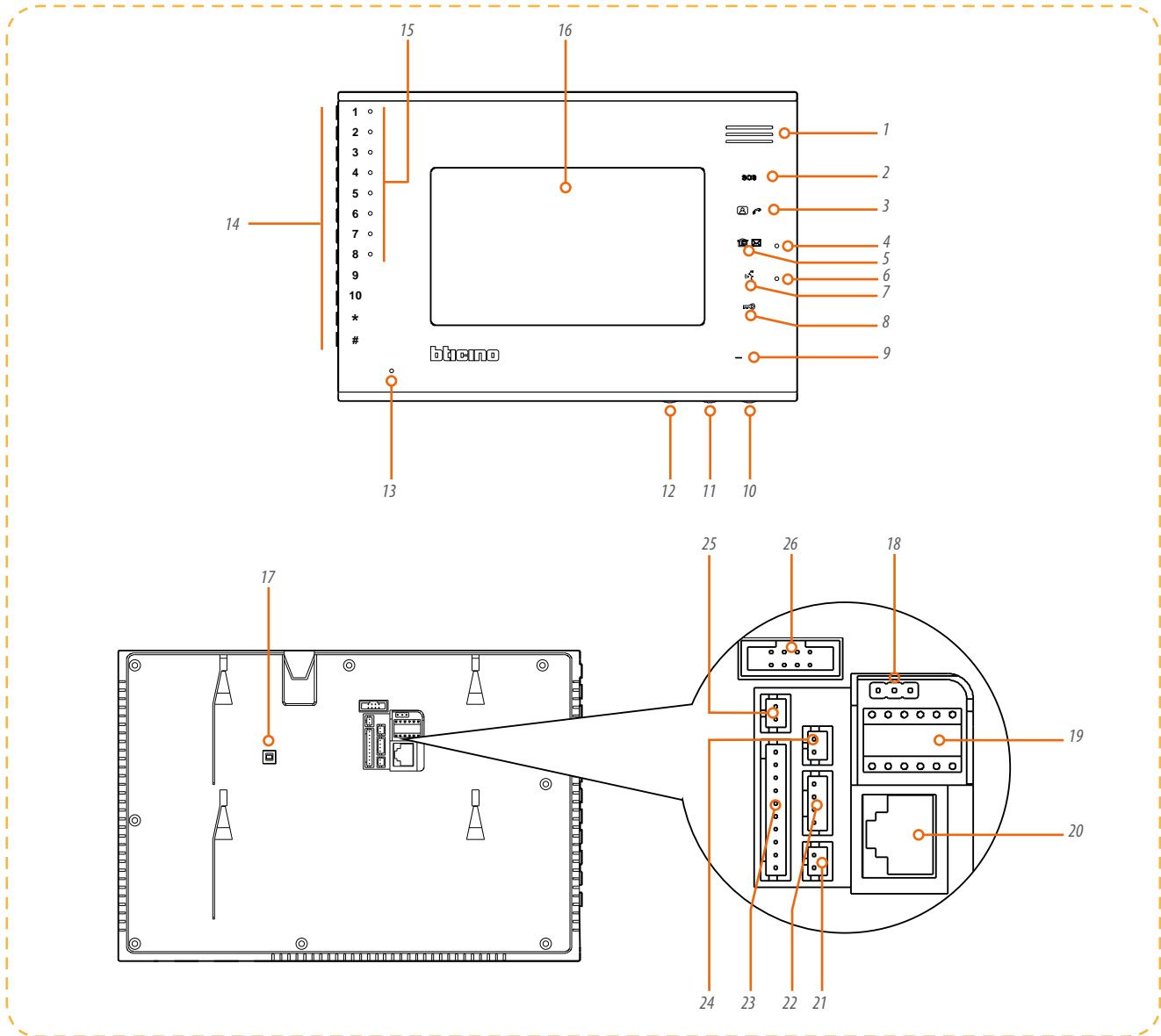
The handset is equipped with 7-inch TFT display screen, Acrylic pushbuttons, 8 alarm areas, it is suitable for wall mounted installation, and has super-thin frame. It's a unique and innovative model with a modern and fashionable style.

321010 colour handset with alarm, 321030 B/W handset with alarm and 321020 B/W handset with alarm can be connected to the D45 EP through the main system riser. The main system riser can be connected to the Switchboard to perform functions such as conversation, monitor and VDE functions. All handsets have an elegant and outstanding outlook and complete functionality, which makes it possible for them to offer top security service and to be the ideal choice for the modern house.

### FUNCTIONS AND FEATURES

- Building intercom: for video intercom with EPs, Small EPs and the Switchboard, as well as with handsets.
- Security alarm: there are eight area alarms, SOS alarm, and anti-tamper alarm, which can warn the Switchboard.
- Silent mode: The ring volume of the handset can be set to silent mode. In this way, when a call is received, a flashing red light comes on but the handset does not ring.
- Mutual ring control: in houses with several handsets, when a call is received all the handsets will ring. When one handset answers the call, all the other will stop ringing and return to standby.
- Priority management function: the handset can stop low-priority intercom operations for high-priority ones.

**322050 - COLOUR HANDSFREE 7"**

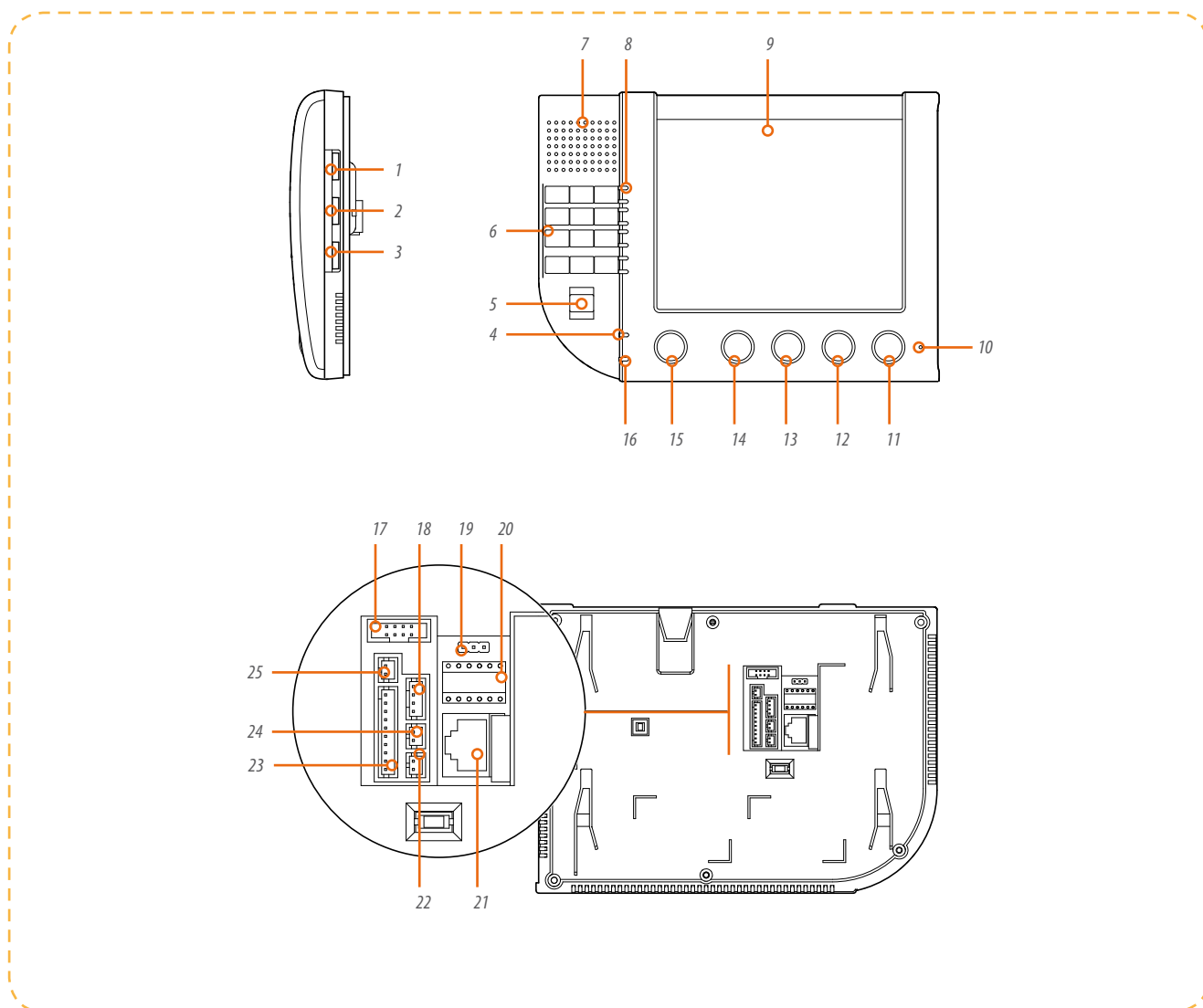


**LEGEND**

- |   |  |
|---|--|
| <ul style="list-style-type: none"> <li>1. Loudspeaker</li> <li>2. SOS key</li> <li>3. Monitor key</li> <li>4. Information LED</li> <li>5. Switchboard call key</li> <li>6. Communication LED</li> <li>7. Answer key</li> <li>8. Unlock key</li> <li>9. Shortcut key</li> <li>10. Color control knob</li> <li>11. Brightness knob</li> <li>12. Ring volume control knob</li> <li>13. Microphone</li> </ul> | <ul style="list-style-type: none"> <li>14. Number keys and corresponding numbers</li> <li>15. Alarm zone LEDs 1 to 8</li> <li>16. Display screen</li> <li>17. Anti removal switch</li> <li>18. Master and Slave pin selection</li> <li>19. Configurators socket</li> <li>20. BUS connector</li> <li>21. SOS alarm connector</li> <li>22. SEP (322020) connector</li> <li>23. Alarm sensors connector (see Wiring diagram 15)</li> <li>24. Door lock interface (323015) connector</li> <li>25. Anti-removal sensor connector</li> <li>26. Serial interface connector</li> </ul> |
|---|--|

# Indoor handset functions overview

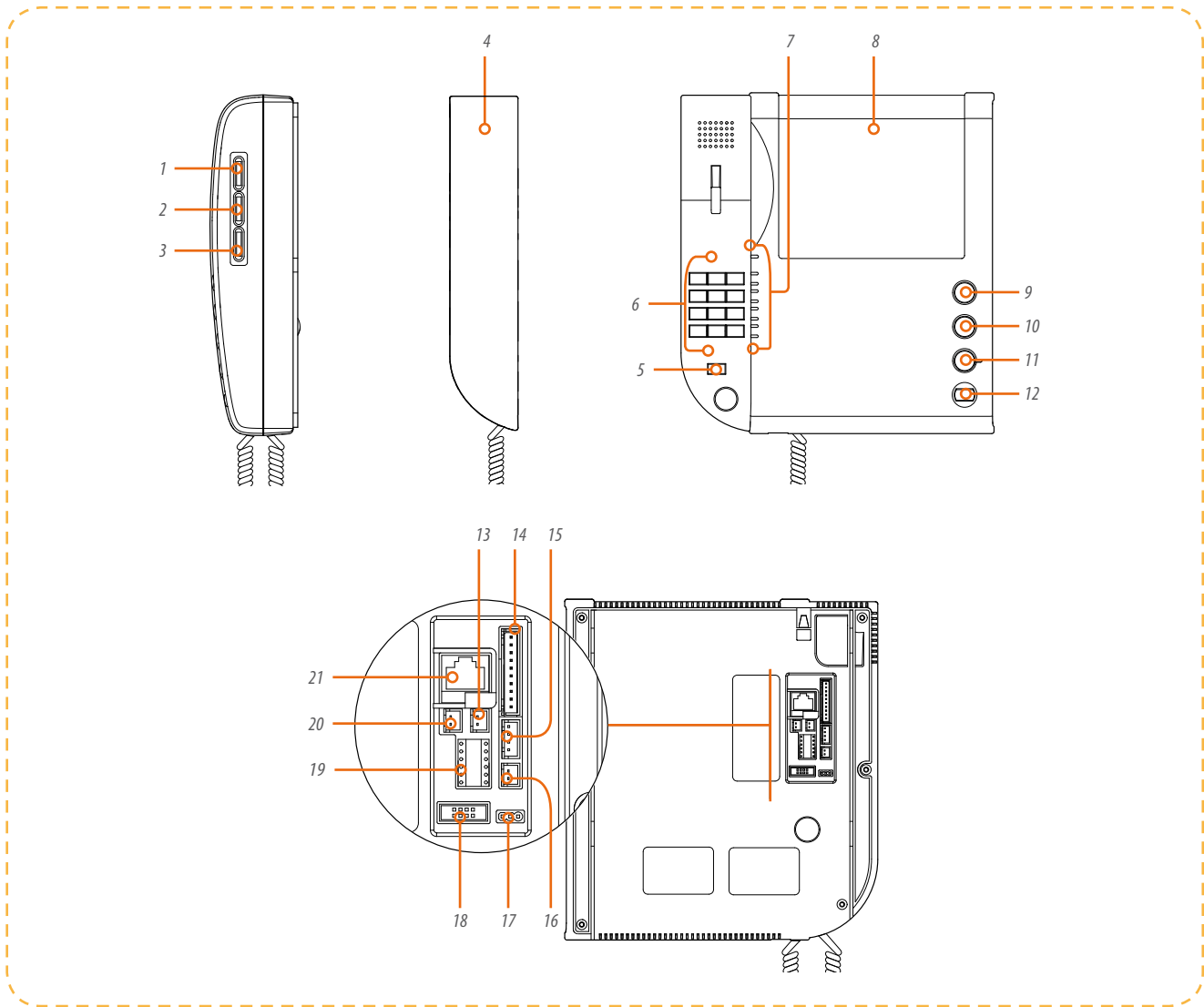
## 321010 - COLOUR HANDSFREE 5.6"



**LEGEND**

- |                            |   |
|----------------------------|---|
| 1. Ring control knob       | 14. Answer key                                      |
| 2. Brightness control knob | 15. SOS key   |
| 3. Colour control knob     | 16. Information LED                                 |
| 4. Communication LED       | 17. Download connector                              |
| 5. Shortcut key            | 18. Small EP connector                              |
| 6. Number key              | 19. Master and slave pin                            |
| 7. Loudspeaker             | 20. Room number configurator connector              |
| 8. Alarm zone LEDs 1 to 8  | 21. BUS connector                                   |
| 9. Display screen          | 22. SOS alarm connector                             |
| 10. Microphone             | 23. Alarm sensors connector (see Wiring diagram 15) |
| 11. Door lock release key  | 24. Door lock release device connector              |
| 12. Monitor key            | 25. Sensor anti-removal alarm connector             |
| 13. Switchboard call key   |   |

**321030 - B/W 4" HANDSET**

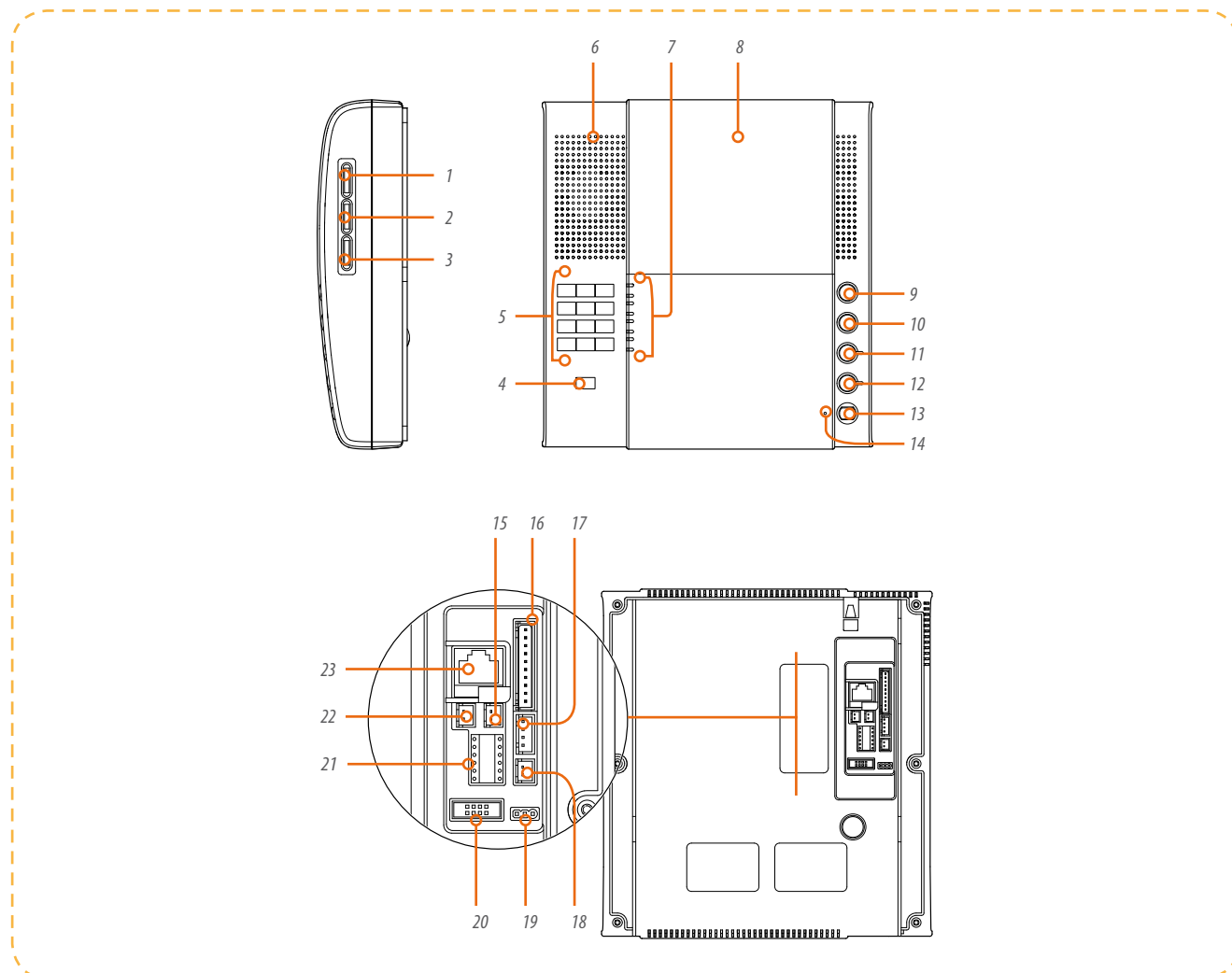


**LEGEND**

- |  |   |
|--|---|
| 1. Ring control knob                       | 12. SOS key   |
| 2. Brightness control knob                 | 13. Sensor anti-removal alarm connector             |
| 3. Contrast control knob                   | 14. Alarm sensors connector (see Wiring diagram 15) |
| 4. Handset                                 | 15. Small EP connector                              |
| 5. Shortcut key                            | 16. Door lock release device connector              |
| 6. Number key                              | 17. Master and slave pin                            |
| 7. Alarm zone LEDs 1 to 8                  | 18. Download connector                              |
| 8. CRT screen                              | 19. Room number configurator connector              |
| 9. Door lock release key                   | 20. SOS alarm connector                             |
| 10. Monitor key                            | 21. BUS connector                                   |
| 11. Switchboard call key + information LED |   |

## Indoor handset functions overview

### 321020 - B/W HANDSFREE 4"



**LEGEND:**

- |  |   |
|--|---|
| 1. Ring control knob                       | 13. SOS key   |
| 2. Brightness control knob                 | 14. Microphone                                      |
| 3. Contrast control knob                   | 15. Sensor anti-removal alarm connector             |
| 4. Shortcut key                            | 16. Alarm sensors connector (see Wiring diagram 15) |
| 5. Number key                              | 17. Small EP connector                              |
| 6. Loudspeaker                             | 18. Door lock release device connector              |
| 7. Alarm zone LEDs 1 to 8                  | 19. Master and slave pin                            |
| 8. CRT screen                              | 20. Download connector                              |
| 9. Door lock release key                   | 21. Room number configurator connector              |
| 10. Monitor key                            | 22. SOS alarm connector.                            |
| 11. Switchboard call key + information LED | 23. BUS connector                                   |
| 12. Answer key + communication LED         |   |

*Note: The Small EP interfaces for the above four handsets can be also used to connect the door-bell switch (Only connect R2 and R3 to the switch). Then you can start the door-bell function through the pushbuttons on the handset. However, when the door bell is started, it will disable the EP, which means that both can't work at the same time.*

## HANDSETS USER SETTINGS

With the handset is standby, enter the user password+ “#” pushbutton. If the wrong password is entered, 3 short beeps will be heard. If the password is correct, the device will enter the main settings menu and an extended beep will be heard.

FUNCTIONAL LIST FOR SETTING AND CHANNEL ALARMS

SETUP ITEM	OPERATION CODE	NEXT OPERATION	MEANING AND INFORMATION FOR THE OPERATION	REMARK		
Change user password	99#	First input“XXXX#”		Note 1		
		Then input“XXXX#”	If the passwords input are the same: 1 long tone, otherwise 3 short tones			
		*	Return to the main setup menu, 1 short tone			
		other keys	Unsuccessful operation: 3 short tones			
2 Select ring tone for calls from system 92#, 93# note 2 92#, 93# please refer to note 2	91#	“XX#” or “X#”	Successful selection: play the selected tone Ineffective selection: 3 short tones, play the original tone	Note 1		
		*	Return to the main setup menu, 1 short tone	Note 2		
		other keys	Unsuccessful operation: 3 short tones			
Disable zone or enable zone (Defense area)	1#	0	Disable zone 1: LED 1 off, 1 long tone	Note 1; Reason for unsuccessful zone enable, note 3.		
		1	Enable zone 1: successful, LED 1 turn on, 1 long tone; unsuccessful 3 short tones.			
		*	Return to main setup menu, 1 short tone			
		other keys	Unsuccessful operation: 3 short tones			
	...	...	...			
	8#	0	Disable zone 8: LED 8 off, 1 long tone			
		1	Enable zone 8: successful, LED 8 on, 1 long tone; unsuccessful 3 short tones.			
		*	Return to main setup menu, 1 short tone			
		other keys	Unsuccessful operation: 3 short tones			
	Enable or disable all zones with shortcut key		If has any zone is already enabled, this operation will disable all the burglar zones, 1 long tone will be heard.		Note 1; Reason for unsuccessful zone enable, note 3.	
			If all zones are disabled, this operation will enable all the zones connected to sensors . if the operation is successful, 1 long tone; if not, 3 short tones.			
	*		Quit setup mode: 1 short tone			
	other		Unsuccessful operation: 3 short tones			

Note 1: set default parameter and setting range

Items	default parameter	setting range
User's password	2000	0000-9999
System ring tone	tone 1	1-12
Ring tone for calls from EP	tone 2	1-12
Ring tone for internal calls	tone 3	1-12

Note 2: the code to set the ring tone for calls from Small EP is 92#; the code to set the ring tone for internal calls is 93#; Other operations are performed using the same method as the method to set the ring tone for calls from the system.

Note 3: reason why enabling of the zone is fail

1. Because the system may be in alarm status (except the infrared sensor). When the alarm sensor (except infrared sensor) is in alarm status, the zone cannot be enabled.
2. Wrong installation settings, or the alarm sensor is not connected. If it's caused by wrong installation settings, a professional is required.
3. Alarm current overload or short circuit.

## RESET USER PASSWORD

If forgot the user password, press pushbutton “#” while in standby and release it after an extended beep heard.

The password will change to the default 2000. At the same time, any alarm messages not sent to Switchboard, will be sent.

## Indoor handset functions overview

### Video door entry functions

#### INSTRUCTIONS

1. For all pushbuttons, the operation is only performed after the pushbutton is released. When holding the pushbutton down is required, the pushbutton should only be released after an extended beep is heard.
2. Operation indication: a short or a long beep indicates successful operation; 3 short beeps or busy tone indicate unsuccessful operation or system busy.
3. If an apartment has several handsets installed, when a call arrives, only the display of the master handset will come on. The display of the other slave handsets will not come on, unless the call is answered by them. However, they will ring together with the master handset.

#### RECEIVING CALLS

##### *Receiving calls from the EP:*

When handset rings, and the call light flashes quickly, it means a call is coming. The display will show the picture recorded by EP camera; press the answer pushbutton or pick up the handset to accept the calls. While the system is busy with the conversation the call light will flash slowly. Press the answer pushbutton or put down the receiver to end the call, than the device will come back to standby status. Unless otherwise specified, "EP" in this manual means (Backbone/ Main EP) or (riser / secondary EP)

*Note: for Handsfree handsets, both answering and terminating a call are done by pressing the answer pushbutton; for Standard handsets, pick up the receiver to answer the call and put down the receiver to terminate the call*

##### *Receiving calls from Small EPs:*

The handset will ring. The procedures are the same as explained in "Receiving calls from the EP".

##### *Receiving calls from the Switchboard:*

When handset rings, and the call light flashes quickly, it means a call is coming. The display will show the picture recorded by Switchboard camera if the Switchboard is fitted with one ; press the answer pushbutton or pick up the handset to accept the calls. While the system is busy with the conversation the call light will flash slowly. Press the answer pushbutton or put down the receiver to end the call, and the device will come back to standby status.

##### *Receiving internal calls:*

The handset will ring. The procedures are the same as explained in "Receiving calls from the EP", but without video.

#### HANDSET MONITORING OTHER DEVICES

##### *Small EP monitoring*

Press the monitor pushbutton twice while in standby. The display will show the picture recorded by Small EP camera. Pick up the receiver to start the conversation, the call light flashed slowly; Put down the receiver to end the conversation. The device will go back to standby status.

*Note: Small EP monitoring function must be enabled during installation settings.*

##### *Monitoring riser Entrance Panels*

Press the monitor pushbutton while in standby. The display will show the picture recorded by riser EP camera. At the monitor status, if there are several riser EPs, press the monitor pushbutton again to view the next riser EP. Using this procedure it will be possible to view all EPs. Pick up the receiver to start the conversation, the call light flashes slowly; Put down the receiver to end the conversation. The device will go back to standby status.

#### CALLING OTHER DEVICES

##### *Calling main Switchboard*

While in standby, press the Switchboard pushbutton to call the Switchboard and wait for the Switchboard to answer the call. Put down the receiver to end the conversation. The device will go back to standby status.

##### *Handset call other Switchboard*

While in stand by, digit Switchboard number + press Switchboard call key or press Switchboard key directly to call main Switchboard. (Such as IU 102 call the 4th. Switchboard): On handset keyboard input 4 key then press Switchboard key within 10 seconds.

*Note: for handsets you must pick up the handset to start conversation.*

##### *Calling internal handsets*

While in standby status, press and hold down the monitor pushbutton until an extended beep is heard. Release the pushbutton to initiate the internal call. Put down the receiver to end the conversation. The device will go back to standby status.

##### *Call other handsets in the same riser*

On handset input IU number + Intercom key – if only intercom key is pressed you call the same IU number. (Such as IU102 call IU104) : on handset keyboard 102 digit 104 + intercom key then long press monitor key and release.

**TIMING**

The longest time the handset can be in operation before picking up the receiver or answering the call is 30 s, after this time the handset automatically switches to standby mode. The longest time the handset can be in operation after picking up the receiver or answering the call is 60 s. After this time the handset automatically switches to standby mode.

**MUTUAL RING CONTROL**

If several handsets are installed inside an apartment, when a call is received and answered from one of the handsets, all the other handsets will stop ringing.

**VDP PRIORITY**

When the handset is monitoring a riser EP, if there is a call from the EP, Switchboard or a Small EP, the handset will stop monitoring and will respond to the call. When the handset is communicating with a Small EP, and there is a call from the EP or the MC, the handset will stop the current communication and respond to the call. When the handset is communicating with other internal handsets, and there is a call from the EP, MC or Small EP, the handset will stop the current communication and respond to the call.

**Door lock release**

When this device and the EP are in operation, press the door lock release pushbutton to release the lock controlled by the EP. When this device and the Small EP are working, press the door lock release pushbutton to release the lock controlled by the Small EP.

**Alarm****TYPE OF ALARM**

Anti-removal alarm, SOS alarm, and zone alarm are three types of alarms.

**ANTI-REMOVAL ALARM**

Anti-removal alarm: when the handset's burglar alarm and the zone alarm are enabled, if the Handset is removed, an anti-removal alarm message will be sent to the Switchboard. If the anti-removal switch is connected to the alarm sensor, when the alarm sensor is dismantled, the handset will also send anti-removal alarm message to Switchboard .

*Note: don't dismantle the handset and the alarm sensor if you use the alarm function.  
Burglar alarm zone are zone 1, zone 2, zone 5, zone 6, zone 7, zone 8; Fire alarm zones are zone 3 and zone 4.*

**SOS ALARM***SOS pushbutton on the panel*

The SOS alarm message will be sent to Switchboard by pressing SOS button.

*External SOS alarm*

The SOS alarm message will be sent to Switchboard by pressing external SOS key. For the setting method, please refer to the "Installation setting operation list" table. The default status of the external SOS is always NO.

**ALARM OPERATION AND ALARM SENDING***Alarm zone connectors*

This device has 8 external sensor connectors. A professional installer is required to install the alarm sensors and setup the software. Burglar alarm zones are zone 1, zone 2, zone 5, zone 6, zone 7, zone 8; Fire alarm zones are zone 3 and zone 4.

*Enabling alarm zones*

The user can enable alarm zones with the user password. For the details of the operation please refer to the table "Functional list for setting and channelling alarms". Once the setup operation has been completed, the alarms for which the zones have been enabled will flash slowly. After the time delay has expired (for burglar alarm zones, the default delay time is 100 s; for fire alarm zones it is 2 s. A professional installer is required to change the time delay), once the sensors are active, they will monitor the situation and send an alarm signal if needed.

*Sending alarms*

When the sensors are active, if any alarm situation occurs, the corresponding alarm zone lights will flash quickly. Meanwhile, a beep will also be emitted for fire alarm zones. For burglar alarms the beep will be emitted if the system has been set to do so during installation.

*Sending and cancelling alarm messages*

When an alarm situation occur, if the alarm is not cancelled during the set time (default time is 40 s), the alarm message will be sent to Switchboard. When an alarm occurs, user can cancel the alarm with the user password. Once the alarm has been cancelled, it will not be sent to Switchboard.

*Disabling alarm zone*

Users can disable alarm zones with the user password. For the operation details please refer to the table "List of operations to enable and disable alarm zones".

*Installation and inspection*

The installer should test the alarm function by simulating an alarm after the parameters have been set and the hardware has been installed, in order to ensure that they are correct.

## Indoor handset functions overview

### Ring volume/ silent mode setup

While in standby, adjust ring adjustment knob to change the ringing volume. When call light turns red, it means the ring volume is at minimum level and the system is in silent mode. Whilst in silent mode, if a call is received the handset call light will flash quickly but the handset will not ring. When the light is blue it means that the handset is in normal ringing mode.

### Brightness and contrast or colour setup

While the device is showing the picture from EP camera or Small EP camera, adjust the brightness and color or contrast adjustment knob to change the brightness and contrast or colour.

### Installation instructions (for the installer)

#### SET THE HANDSET ROOM NO.

There are two ways to set the room number for colour handsets:

- Set room number #FFII using configurators. This method has high priority. Each time the configurator is changed, the power needs to be disconnected and reconnected again to activate the configurator. To set room number 0806, insert configurators 0, 8, 0, 6 in the relevant sockets (for the detailed operations please refer to the system configuration chapter).

*Note: if the room number is set beyond the apartment numbers of each floor, then the settings will be consider as ineffective.*

- Set the room number using the keyboard. This method has low priority. This means that if the configurator method is also used, the handset will accept the parameters from the configurator first.
- 322040 handset can only be configured using the keyboard.

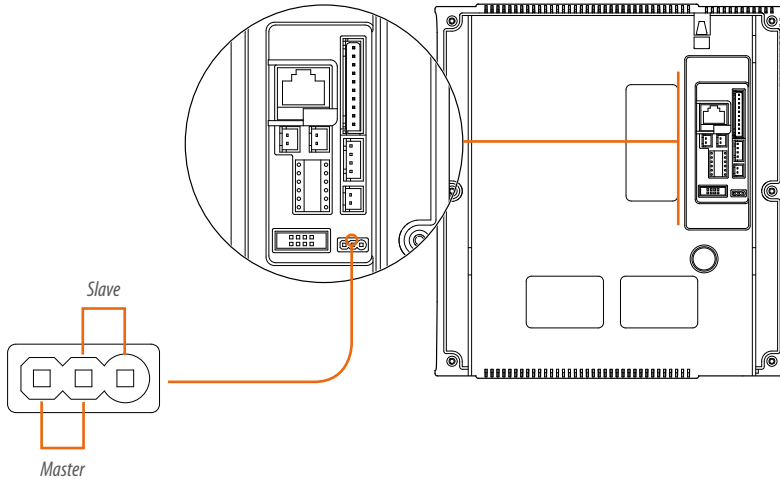
### Setting the number of apartments per floor

1. Set the apartment number #II using configurators. This method has high priority. Every time after change configurator, the power need be cut and reconnected to active the configurator. To set apartment number 6, insert configurators 0 and 6 in the relevant sockets on the back of the handset (for the detailed operations please refer to the system configuration chapter).
2. Set the floor apartment number using the keyboard. This method has low priority. This means that if the configurator method is also used, the handset will accept the parameters from the configurator first.

3.

*Note: if not set, the default floor apartment number will be 4.*

**MASTER AND SLAVE SETTINGS**



MASTER AND SLAVE SETTINGS	MASTER
Set as the master handset	<p>Or not jump</p>

MASTER AND SLAVE SETTINGS	SLAVE
Set as the slave handset	

Drawings as above, set at the back of the handset according to the marks. Default is master handset. After setting, reconnect the power to activate the new settings.

**Installing Small EPs**

If a Small EP is required, connect the Small EP to the “Small EP connector” on the master handset. You can enable the monitoring Small EP function during installation setup.

**Install Small EPs door lock releases**

If an electric door lock release is required for the Small EP, a door lock accessory is required for the door lock release function.

**External SOS switch**

The external SOS switch is installed at the back of the handset “SOS alarm connector” and can be set as always open (NO type) or always closed (NC type) using the keyboard. The default status is always open (NO type).

**Alarm sensors connections**

8 alarm defence areas can be defined for each IU. Infrared theft sensors, door sensors, smoke and gas sensors can be connected directly to the IU. Check that the cable connections between the IU and the sensors are correct and avoid cable cutting. When connecting sensors, a 10 KΩ parallel resistor + a 10 KΩ resistor in series are required. Resistors should be placed close to the sensor port in order to ensure that an alarm can be sent when the handset is forcefully removed.

*Note : IU can afford 12 Vdc sensors type and total sensors current should not exceed a maximum of 300 mA. If maximum current is more than 300 mA, than an additional power supply must be used. Maximum cable distance between sensors and IU is ≤ 50 m, suggested to use 0.5 mm<sup>2</sup> section cable.*

**Anti-removal installation for sensors**

The handset alarm has an anti-removal function. The handset has an external sensor connector. When the Alarm sensor is removed, the handset can send an anti-removal alarm message to the Switchboard. The connector requires that the alarm sensor output is NC after the alarm sensor is remove. After installation is completed and the burglar alarm is enabled, the handset will automatically check the anti-removal signal of the sensor. If the sensor is removed, the handset will send an anti-removal message to the Switchboard.

## Indoor handset functions overview

### INSTALLATION SETUP

When the handset is in standby and all zone alarms are disabled, press “#”, then enter the fixed installer password 686868, and press “#” to confirm. If the wrong password is entered, 3 short

beeps will be heard; if the password is correct, an extended beep will be heard, and the unit will switch to installation setup status. The 8 alarm lights and the message light will be off

INSTALLATION SETTING OPERATION LIST TABLE

SETUP	OPERATION CODE AND LIGHT STATUS	NEXT OPERATION	MEANING AND INFORMATION FOR THE OPERATION	REMARK		
Set room number for handset	11# 8 alarm lights and message light off	“FFll#”	correct parameter input: 1 long tone wrong parameter input: 3 short tones	Default room number: 101		
		*	return to main menu of installation setup, 1 short tone			
		other	unsuccessful operation: 3 short tone			
Set apartment quantity per floor	12# 8 alarm lights and message light off	“ll#” or “l#”	correct parameter input: 1 long tone wrong parameter input: 3 short tones	Range:1-99 Default:4; it can be set only when there is no setting for hardware		
		*	return to main menu of installation setup, 1 short tone			
		other	unsuccessful operation: 3 short tones			
Set external SOS to be always on or always off	15# message light will indicate status of this setting item	1	SOS external switch or pushbutton always open (NO): message light on, 1 long tone	Default: always open		
		0	SOS external switch or pushbutton always close (NC): message light off, 1 long tone			
		*	return to main menu of installation setup, 1 short tone			
		other	unsuccessful operation: 3 short tones			
Enable and disable function of monitoring Small EP	17# message light will indicate status of this setting item	1	enable: handset can monitor Small EP: message light on, 1 long tone	Default: cannot monitor Small EP. This function is available only when the function is set as Small EP function.		
		0	Shielded: handset can not monitor Small EP: message light off, 1 long tone			
		*	return to main menu of installation setting, 1 short tone			
		other	unsuccessful operation: 3 short tones			
Return all the parameters to default value	19# message light will indicate status of this setting item	1	Get all the default parameters: message light on, 1 long tone			
		0	Do not get all the default parameters: message light off, 1 long tone			
		*	return to main menu of installation setup, 1 short tone			
		other	unsuccessful operation: 3 short tones			
Enable and disable sensors	21# Message light is off. 8 alarm lights will indicate status of each alarm zone	1#	1	1 alarm zone with sensor: LED 1 on, a long tone.	Default: (all) without sensor	
			0	1 alarm zone without sensor: LED 1 off, a long tone.		
			*	return to previous menu, 1 short tone		
			other	Ineffective operation: 3 short tones		
		...	...			
		8#	1	8 alarm zone with sensor: LED 8 on, a long tone.		
			0	8 alarm zone without sensor: LED 8 off, a long tone.		
			*	return to previous menu, 1 short tone		
			other	unsuccessful operation: 3 short tones		
		*	return to main menu of installation setting, 1 short tone			
		other	unsuccessful operation: 3 short tones			
		Set NO and NC type of sensors	22# 8 alarm lights will indicate status of each alarm zone.	1#		1
0	always-close (NC) sensor for alarm area 1: LED 1 off, 1 long tone					
*	return to previous menu, 1 short tone					
other	unsuccessful operation: 3 short tones					
...	...					
8#	1			always-open (NO) sensor for alarm area 8: LED 8 on, 1 long tone		
	0			always-close (NC) sensor for alarm area 8: LED 8 off, 1 long tone		
	*			return to previous menu, 1 short tone		
	other			unsuccessful operation: 3 short tones		
*	return to main menu of installation setup, 1 short tone					
other	unsuccessful operation: 3 short tones					

**INSTALLATION SETTING OPERATION LIST TABLE**

SETUP	OPERATION CODE AND LIGHT STATUS	NEXT OPERATION	MEANING AND INFORMATION FOR THE OPERATION	REMARK		
Set infrared sensor	23# Message light is off. 8 alarm lights will indicate status of infrared sensor. Setting: infrared sensor: light of this alarm zone will be on. Non-infrared sensor, light of this alarm defence area zone will be off.	5#	1	infrared sensor for alarm zone 5: LED 5 on, 1 long tone	Note: 1/2/3/4 alarm zone are defined as infrared alarm zones, door alarm, smoke alarm, gas alarm. They cannot be changed. 5/7 are defaulted as infrared alarm zones s. 6/8 alarm are defaulted as non-infrared alarm zones	
			0	non- infrared sensor for alarm zone 5: LED 5 on, 1 long tone		
			*	return to previous menu, 1 short tone		
			other	unsuccessful operation: 3 short tones		
		.....	.....	.....		
		8#	1	infrared sensor for alarm zone 8: LED 8 on, 1 long tone		
			0	Non-infrared sensor for alarm zone 8: LED 8 on, 1 long tone		
			*	return to previous menu, 1 short tone		
			other	unsuccessful operation: 3 short tones		
			*	return to main menu of installation setup, 1 short tone		
			other	unsuccessful operation: 3 short tones		
Setting for Time delay after alarm set	24# The light of the zone indicates the parameter For example, if the parameter is 3, then LED 3 will on	1	delay 40 s: 1 long tone, only LED 1 will on	Default: 100 s only for thief area alarm		
		2	delay 100 s: 1 long tone, only LED 2 will on			
		3	delay 150 s: 1 long tone, only LED 3 will on			
		4	delay 210 s: 1 long tone, only LED 4 will on			
		5	delay 255 s: 1 long tone, only LED 5 will on			
		*	return to main menu of installation setup, 1 short tone			
		Other	unsuccessful operation: 3 short tones			
Setting for Time delay after alarm happens	25# The light of defence area give the parameter. For example, if the parameter is 3, then LED 3 will on	1	delay 40 s: 1 long tone, only LED 1 will on	Default: 40 s only for thief area alarm		
		2	delay 100 s: 1 long tone, only LED 2 will on			
		3	delay 150 s: 1 long tone, only LED 3 will on			
		4	delay 210 s: 1 long tone, only LED 4 will on			
		5	delay 255 s: 1 long tone, only LED 5 will on			
		*	return to main menu of installation setup, 1 short tone			
		other	unsuccessful operation: 3 short tones			
Enable and disable sound alarm for thief	26# The Information LED indicates the setup state	1	enabled: if there is a burglar alarm, loudspeaker will emit a sound. Message light on, 1 long tone	Default: no sound		
		0	disabled: if there is a burglar alarm, loudspeaker will not emit a sound. Message light off, 1 long tone.			
		*	return to main menu of installation setup, 1 short tone			
		other	unsuccessful operation: 3 short tones			
	*	exit main menu of installation setup, 1 short tone				
	other	unsuccessful operation: 3 short tones				
1) Doorbell function setup (if is doorbell function , it is not Small EP function)	16# The information LED to give setup state	1	Enable doorbell function, the information LED is on, 1 long tone.	Default: is not doorbell function, tt is Small EP function.		
		0	Disable doorbell function, the information LED is off, 1 long tone			
		*	return to main menu of installation setup, 1 short tone			
		other	unsuccessful operation: 3 short tones			
2) Handset connection to Apartment interface function setup	13# The information LED to give setup state	1	handset has connected to the Apartment interface the information LED is on, 1 long tone,	Default: Handset not connected to the Apartment interface.		
		0	handset has not connected to the Apartment interface, the information LED is off, 1 long tone.			
		*	return to main menu of installation setup, 1 short tone			
		other	unsuccessful operation: 3 short tones			

1) To Install doorbell function complete the two steps below:  
Connect the Small EP connector to R2, and the R3 pin to the doorbell switch;  
To use the doorbell function the setup procedure must be completed. The Small EP function cannot be used.

2) The handset can communicate with the 323009 device when powered or set.  
Based on the communication result, the handset can change the setup parameters.  
If the handset is to be connected to 323009, then the handset number will be changed to 101 automatically.

## Indoor handset functions overview

### TROUBLESHOOTING

1. **Small EP short circuit.** The handset emits 3 short beeps, stops communication with the Small EP and switches to standby.
2. **Overload or short circuit check for alarm sensor.** After setting the alarm zone, the handset will supply  $12 \pm 1V$  DC to the sensors. The maximum current it can provide is 300mA. If more current is required, please connect an additional power supply. In case of short circuit, 3 short beeps will be heard, and an overload alarm message will be sent to MC. Meanwhile, all the zone lights will come on (at this time, other functions will be performed normally, with the exception of the alarm function). Wait 10 seconds and reconnect the power and correct the mistake. Reset the alarm zone, the handset will start operating normally.
3. **Cannot enable the alarm zone**  
If the alarm zone cannot be enabled, do the following:  
Hardware: ensure that the sensors are connected correctly. Software: in order to enable the zones, it will first be necessary to enable the sensors, select the status of the sensors (always open or always close ), set the sensors to infrared or non-infrared as required, set all the sensor parameters. Once all these settings have been entered exit the installation setup procedure. Enter the user password to enable or disable zone.

*Note: the non-infrared sensor zone can't be set when there is an active alarm.*

*Colour handsfree 7" alarm  
322050*



**322040 - AUDIO HANDSET**

**FUNCTIONS**

322040 is an audio handset. It has basic functions such as VDP and door lock release. It's small in size and has a low power consumption.

**OUTLOOK AND CONNECTOR**

*Introduction*

Unless otherwise specified, the functions described below are all in normal mode.

*Meaning of the standby status*

When there is no calls or no settings are being entered, this manual will indicate the unit as in standby status.

**INSTALLATION NOTES**

1. *Install Small EP.*  
When installing a Small EP, this must be connected to master IU when there are 2 or 3 IUs in the apartment.
2. *Installing the electric door lock.*  
When connecting the Small EP to the electric door lock, item 323015 is necessary for performing the door lock release function;
3. *Install the SOS external switch*

*Setup notes*

1. During the setup operations, if no keys are pressed for 10 s the device will emit three short sound and return to standby.
2. If during the setup operation the wrong key is pressed or the wrong parameter is entered, 3 short sounds will be heard. At the same time the device will return to the initial installation setup status.
3. During installation setup status the handset stops all call functions and cannot respond to any calls. However, if any call is received, a short sound will be heard as indication.
4. When the power is reconnected the parameters set during the setup process will still be valid.
5. The functions of each pushbutton while in installation setup status:
  - Long Press of (MC) Switchboard call key: select the submenu;
  - press the (MC) Switchboard call key pushbutton: change parameter;
  - door lock release pushbutton: select setting item or exit.

**INSTALLATION SETTINGS**

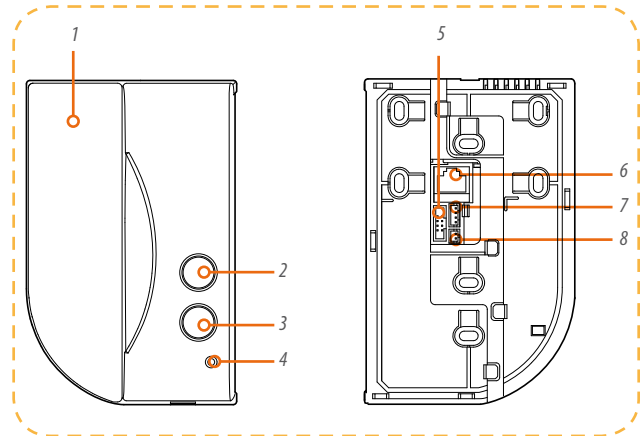
*Enter the initial installation setup status.*

At standby, press and hold the door lock release pushbutton until 1 long beep is heard. The call light will be off. Enter the initial installation setup status without selecting any submenus.

*Note: during the installation setup the handset cannot make calls. If any call is received, a short sound will be heard as indication. However the handset will be unable to answer.*



Audio handset  
322040



**LEGEND:**

1. Handset
2. Door lock release key
3. (MC) Switchboard call key
4. Communication LED
5. Serial interface connector
6. System BUS connector
7. Small EP connector
8. External SOS alarm connector

**FUNCTION SETUP**

*SOS alarm function*

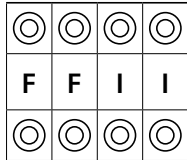
In case of external SOS alarm the switch or pushbutton changes to alarm status, the handset will send SOS alarm message to Switchboard.

## Indoor handset functions overview

### 322040 - AUDIO HANDSET

Set the installation parameters

Set the handset household no.



FUNCTIONS	OPERATION	REMARKS
Enter the household number setup submenu	While in the initial installation setup status press and hold down the MC pushbutton once to enter the household number setup submenu. Note: the first number to set after entering the submenu is the thousand position.	Household number range is 101-9999. Default number is 101. The two numbers after 101 cannot be higher than the number of households per floor.
Set the parameter	Press the MC pushbutton to add 1 unit to the relevant position. If the pushbutton is pressed after the input parameter has reached 10, 3 short beeps will indicate wrong operation and the device will exit the household number setup submenu automatically and return to the initial installation setup status.	
Select the setting and exit the setup submenu	Press the door lock release pushbutton to move to next setting position, the order is: thousands, hundreds, tens and units. Note: 1) If no number is entered in a position, the default 0 will apply. 2) After setting the units position press the door lock release key to exit household number setup and return to the initial installation setup status. If the household number is set correctly, a long beep will be heard when exiting the menu, and the number will be saved; otherwise, 3 short beeps will be heard and the number will be not saved	
Exit	1) Press the door lock release pushbutton to move to the last item. Press the door lock release pushbutton again to exit household number setup and return to the initial installation setup status. 2) If the operation is performed wrongly, 3 short beeps will be heard the unit will automatically return to the initial installation setup status.	

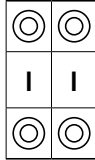
#### EXAMPLE:

If the household number must be set to 403, then the relative parameter should be: 0 for thousands, 4 for hundreds, 0 for tens and 3 for units.

While in the initial installation setup status press and hold down the (MC) Switchboard call key once to enter the household number setup submenu. The current position is thousands Since the parameter for thousands is 0, press the door lock release pushbutton to move to the hundreds position. The parameter for the hundreds is 4, press the (MC) Switchboard call key 4 times, then press door lock release pushbutton to move to the tens. Since the parameter for

tens is 0, there no need to press the (MC) Switchboard call key, just press the door lock release pushbutton to move to the units. Since the parameter for the units is 3, press the (MC) Switchboard call key 3 times. Then press the door lock release key to return to the initial installation setup status and check at the same time if the settings entered are correct. If they are correct, 1 long beep will be heard. Otherwise 3 short beeps will be heard. Once in the initial installation setup status press and hold the door lock release pushbutton to exit setup status and return to standby status.

### Setting the number of households per floor



FUNCTIONS	OPERATION	REMARKS
Enter setup submenu for number of households per floor	While in the initial installation setup status, press and hold the MC pushbutton twice to enter the setup submenu for the number of households per floor. Note: the first number to set after entering the submenu is the tens position.	The number of households per floor cannot be less than the household number. the range is 1-99. The default number is 4.
Set the parameter	Press the MC pushbutton to add 1 unit to the relevant position. If the pushbutton is pressed after the input parameter has reached 10, 3 short beeps will indicate wrong operation and the device will exit the number of households setup submenu automatically and return to the initial installation setup status.	
Select setting item and exit the submenu	Press the door lock release pushbutton to move to the next setting position, the order is: tens- units-exit current setting item, back to initial installation setup status. After moving to that position, the parameter of that position will be 0. Before exiting, please check if the setting parameter is correct. If correct, a long beep will be heard and the set parameter will be saved. Otherwise, 3 short beeps will be heard and the parameter will not be saved.	
Exit	1) Press the door lock release pushbutton to move to the last item. Press the door lock release pushbutton again to exit the current submenu and return to the initial installation setup status. 2) If the operation is performed wrongly, 3 short beeps will be heard the unit will automatically return to the initial installation setup status.	

### Set external SOS to be NO/NC

FUNCTIONS	OPERATION	REMARKS
Select the setup submenu for SOS NO/NC	While in the initial installation setup status, press and hold the MC pushbutton five times to enter the setup submenu for SOS NO/NC. Read the current parameter. If it's NO, the parameter is 1 and the message light will be on. If it's NC, the parameter is 0 and the message light will be off.	Default: always on
Set the parameter	Press the MC pushbutton to increase the parameter by 1. The parameter will return to 0 after it reaches to 2. When parameter is 1, SOS is NO type, and the message light is also on. When parameter is 0, SOS is NC type, and message light is also off. During setup the parameter will be saved automatically.	
Exit	1) Press the door lock release pushbutton to exit the current submenu and return to the initial installation setup status. 2) If the operation is performed wrongly, 3 short beeps will be heard the unit will automatically return to the initial installation setup status.	

#### EXAMPLE:

Once in the initial installation setup status press and hold MC 5 times. If SOS status is the default parameter, the message light will be on, which means the SOS is NO type. Press the Switchboard call key once, message light will go off, which means SOS will be always off. Press the Switchboard call key once, message light will go on, which means SOS will be NO type. Other operation may be deducted by analogy. Finally, press the door lock release pushbutton to exit the initial installation setup status. Once in the initial installation setup status press and hold the door lock release pushbutton to exit the installation setup status and return to standby status.

## Indoor handset functions overview

### 322040 - AUDIO MASTER AND SLAVE HANDSET

FUNCTIONS	OPERATION	REMARKS
Select the "Set master and slave handsets" setup submenu	While in the initial installation setup status, press and hold the MC pushbutton 8 times to enter the setup submenu "Set master and slave handsets" Read the current parameter. For master handsets the parameter is 1 and the message light will be on. For slave handsets the parameter is 0 and the message light will be off.	Note: only one master handset per household number is allowed. All the other handsets should be set to slave.
Set the parameters	Press the MC pushbutton to increase the parameter by 1. The parameter will return to 0 after it reaches to 2. When parameter is 1, the handset is a slave handset, and the message light is on. When the parameter is 0, the handset is a master handset and the message light will be off. During setup the parameter will be saved automatically.	Default: slave handset
Exit	1) Press the door lock release pushbutton to exit the current submenu and return to the initial installation setup status. 2) If the operation is performed wrongly, 3 short beeps will be heard the unit will automatically return to the initial installation setup status.	

To install doorbell function the two steps below need to be completed:

1. Connect SMALL EP connections R2 and R3 to the doorbell switch.
2. Before using doorbell function, the setup procedure must be completed.

FUNCTIONS	OPERATION	REMARKS
Select setup submenu for the doorbell function	While in the initial installation setup status, press and hold the MC pushbutton six times to enter the setup submenu for enabling the doorbell function. Read the current parameter. If it's enabled, the parameter is 1 and the message light will be on. If it's disabled, the parameter is 0 and the message light will be off.	Default: disabled. This apply to the Small EP function and not to the doorbell function.
Set the parameter	Press the MC pushbutton to increase the parameter by 1. The parameter will return to 0 after it reaches to 2. When parameter is 1, the handset able to use the doorbell function, and the message light is on. When the parameter is 0, the handset is unable to use the doorbell function, and the message light is off. During setup the parameter will be saved automatically.	
Exit	1) Press the door lock release pushbutton to exit the current submenu and return to the initial installation setup status. 2) If the operation is performed wrongly, 3 short beeps will be heard the unit will automatically return to the initial installation setup status.	

FUNCTIONS	OPERATION	REMARKS
Select setup submenu for enabling connection to item 323009	While in initial installation setup status, press and hold the MC pushbutton three times to enter the setup submenu for enabling connection to item 323009. Read the current parameter. If it's enabled, the parameter is 1 and the message light will be on. If it's disabled, the parameter is 0 and the message light will be off.	Default: disable. this means that the handset is not set to connect to item 323009
Set the parameter	Press the MC pushbutton to increase the parameter by 1. The parameter will return to 0 after it reaches to 2. When parameter is 1, the handset is set to connect to the apartment interface, and the message light is on. When parameter is 0, the handset is not set to connect to the apartment interface, and the message light is off. During setup the parameter will be saved automatically.	
Exit	1) Press the door lock release pushbutton to exit the current submenu and return to the initial installation setup status. 2) If the operation is performed wrongly, 3 short beeps will be heard the unit will automatically return to the initial installation setup status.	

*Note: The handset can communicate with the 323009 device when powered up or set to do so. Based on the communication result, the handset can change the setting parameter. If the handset is to be connected to item 323009, then the handset number will be changed to 101 automatically.*

### Recovering all the default parameters

FUNCTIONS	OPERATION	REMARKS
Select setup submenu of "recover all the default parameters"	While in the initial installation setup status, press and hold the MC pushbutton nine times to enter the setup submenu "recover all the default parameters".	Default: disable. this means that the handset is not set to connect to the apartment interface
Set the parameter	Press MC pushbutton to recover all the installation setup parameters. The message light will be on.	
Exit	1) Press the door lock release pushbutton to exit the current submenu and return to the initial installation setup status. 2) If the operation is performed wrongly, 3 short beeps will be heard the unit will automatically return to the initial installation setup status.	

### Exit installation setting

Press and hold the door lock release pushbutton until 1 long beep is heard. Release to exit setup status. If while in setup status no operation is performed for 10 s, the handset will automatically return to standby.

### INSTRUCTIONS:

1. For all pushbuttons, the operation is only performed after the pushbutton is released. If necessary to hold the pushbutton, this should only be released after one extended beep is heard.
2. Operation indication: a short beep indicates that the operation has been successful; 3 short beeps or busy tone indicate unsuccessful operation, or system is busy.
3. In power saving mode, the handset is able to receive but not make calls.

### RECEIVING CALLS

#### Receiving calls from the EP:

When the handset rings, and the call light flashes quickly, it means that a call is coming. The display will show the picture recorded by EP camera; press the answer pushbutton or pick up the handset to accept the calls. While the system is busy with the conversation the call light will flash slowly. Press the answer pushbutton or put down the receiver to end the call, and the device will come back to standby status. Unless otherwise specified, "EP" in this manual means main EP or UEP.

*Note: for Handsfree handsets, both answering and terminating a call are done by pressing the answer pushbutton; for Standard handsets, pick up the receiver to answer the call and put down the receiver to terminate the call*

#### Receiving calls from Small EPs:

The handset will ring. The procedures are the same as explained in "Receiving calls from the EP".

#### Receiving calls from the Switchboard:

When the handset rings, and the call light flashes quickly, it means that a call is coming. Press the answer pushbutton or pick up the handset to accept the calls. While the system is busy with the conversation the call light will flash slowly.

Press the answer pushbutton or put down the receiver to end the call, and the device will come back to standby status.

#### Receiving internal calls:

The handset will ring. The procedures are the same as explained in "Receiving calls from the EP", but without video.

### CALLING OTHER DEVICES

#### All Switchboards

While in standby press the MC pushbutton to call Switchboards and wait for the call to be answered. Replace the handset to end the conversation. The device will go back to standby.

*Note: for standard handsets you must pick up the handset to start conversation.*

#### Calling internal handsets

While in standby, press and hold the (MC) Switchboard call pushbutton until 1 long beep is heard. After release, the call made will be an internal call. Replace the handset to end the conversation. The device will go back to standby.

## Indoor handset functions overview

### TIMING

The longest time the handset can be in operation before picking up the receiver or answering the call is 30 s, after this time the handset automatically switches to standby mode. The longest time the handset can be in operation after picking up the receiver or answering the call is 60 s. After this time the handset automatically switches to standby mode.

### MUTUAL RING CONTROL

When several handsets are installed inside the apartment, when a call is received all handsets will ring. If the call is answered by one handset, all the others will also stop ringing.

### VDP PRIORITY

If while the handset is communicating with a Small EP a call from the EP or the Switchboard is received, the handset will terminate the current communication and answer the incoming call. If while the handset is communicating with an internal handset a call from the EP, the Switchboard, or the Small EP is received, the handset will terminate the current communication and answer the incoming call.

### Door lock release

When the handset and the EP are in communication, press the door lock release pushbutton to release the EP door lock. When the handset and the Small EP are in communication, press the door lock release pushbutton to release the Small EP door lock.

### Alarm

#### SOS ALARM

*SOS pushbutton on the panel*

The SOS alarm message will be sent to Switchboard by pressing MC button.

*External SOS alarm*

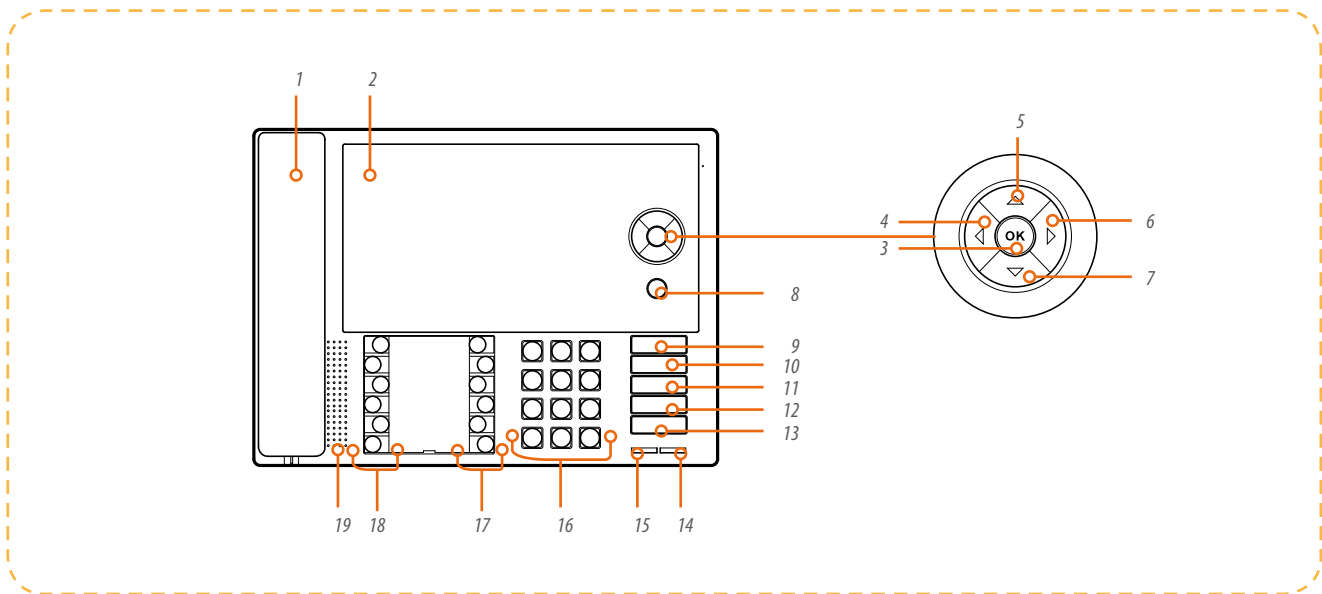
The SOS alarm message will be sent to Switchboard by pressing MC key. For the setup procedure please refer to "Table 2 Installation settings operation list", external SOS NO or NC setup. The default status is always NO.

## Switchboard overview

### 323001 - SWITCHBOARD

The Switchboard is the core of the network system intelligently managed residential apartment blocks. It is based on 32 bit embedded CPU and FPGA platform technology with high resolution 7" digital LCD. The device can manage not only the local computerised Switchboard system, but can also be linked by LAN to other computerised Switchboard for the management of larger systems. The Switchboard is able to communicate with handsets, EPs and other Switchboards with colour display, can record alarms and call event. It can make calls using shortcut key, perform cycle monitoring, call forwarding and the main Switchboard own functions. It's capable of saving thousands of calls and alarm records. It provides quick message retrieval according to handset address.

Switchboard

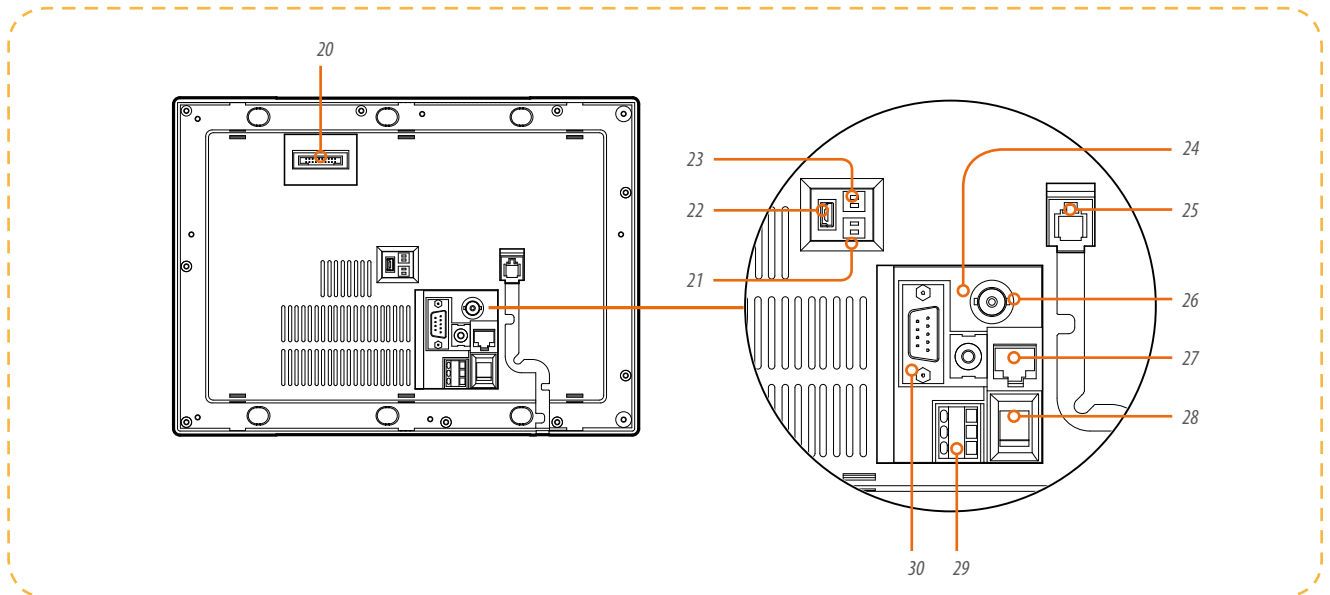


**LEGEND:**

- |                           |                                |
|---------------------------|--------------------------------|
| 1. Handset                | 11. Address Book               |
| 2. Screen                 | 12. Monitor key                |
| 3. Confirm key            | 13. Handsfree                  |
| 4. Left key               | 14. SOS Indicator              |
| 5. Up key                 | 15. Communication indicator    |
| 6. Right key              | 16. Digital keyboard           |
| 7. Down key               | 17. User-defined Key F07 – F12 |
| 8. Return key             | 18. User-defined Key F01 – F06 |
| 9. Call key               | 19. Loudspeaker                |
| 10. Door lock release key |                                |

# Switchboard overview

## 323001 - SWITCHBOARD



### LEGEND

- 20. JTAG connector
- 21. Video output amplifying DIP switch
- 22. USB connector
- 23. Video input amplifying DIP switch
- 24. RCA video input connector
- 25. RJ11 handset connector
- 26. BNC video input connector
- 27. RJ45 system BUS connector
- 28. Power switch
- 29. SOS alarm connector
- 30. COM (alternate)

### VIDEO GAIN SETTING:



System BUS to Switchboard video gain setting, video input gain control . Users can set the video gain according actual video conditions.



Video gain setting from Switchboard to system BUS, video input gain control. Users can set the video gain according actual video conditions.

### DIP switch setting instruction

	Distance	1	2
<b>COLOUR OR B/W VIDEO</b>	0 – 300 m	OFF	OFF
	300 – 700 m	ON	OFF
	700 – 1000 m	ON	ON

*Note: The above video gain setting data are just for reference. To adjust and set data take into account the actual image.*

### MAIN FEATURES:

#### Hardware features

1. Using a standard RJ45 interface, making it easy to install and connect different systems as a network, and managed as districts;
2. Audio and video signals are differential signal, and a twisted pair is used for their transmission. The image is clear and stable. It is possible to adjust the video gain and support long distance transmission of audio and video signals;
3. The handsfree can also be connected to entrance panels. Possibility of switching from handsfree communication mode to handset communication with clear intercom effect. 7 inch colour high resolution (800x480) LCD display. It can communicate with and monitor riser and standard EP with high quality audio and video signals. Interface for external camera available. The external camera can be used for video intercom with handsets.
4. higher electronic disturbance immunity performance.

## FUNCTION FEATURES

1. Digital intelligent control. Navigation pushbutton, with graphic icon menu for easy operation. Possibility of real time caller and recipient address information display. Function parameters setup using the menu and possibility of updating the software;
2. Many ways to call and monitor: calling or monitoring by input device (EP/HANDSET/other Switchboard) address, or by address book;
3. User-defined function shortcut keys: 12 user defined key enabling the user to call handsets, EP and other Switchboard at the press of a button. Entrusted or not can also be shifted by one pushbutton etc.;
4. Management by district: The Switchboard has its own address book for saving handsets, EP, and all Switchboard of the system, providing full district management. These services can all be called using the address book. The address book can be downloaded using the 323020 software;
5. Cycle check: The handset performs real time handset alarm checks to detect any faults. The function is active and the cycle check interval can be set.
6. Sort: system classify main Switchboard and subsystem Switchboards. Main Switchboard can only be installed on backbone BUS. Subsystem Switchboards can be installed on riser BUS.
7. Communication record management: capable of recording thousands of communication records, which are easy to browse;
8. Alarm recording process: possibility of real time check of all alarm sensors with burglar, fire, gas etc. alarm notifications. Easy to view alarm info. Reminder to solve pending alarms through real time indications;
9. Power supply monitor function: capable of monitoring the system power supply;
10. Call forwarding: visitors can call Switchboard from the UEP and the main EP to check resident room number. The Switchboard can forward the UEP and main EP call to the handset. Using this function two handsets can communicate with each other.
11. Cycle monitoring function: it can monitor all main EP and riser EP in succession. No need call them individually;
12. Function transfer: when subsystem Switchboard are left unattended all calls can be transferred to the main Switchboard. When in this mode, sub-menu are unable to answer calls.

# Switchboard overview

## 323001 - SWITCHBOARD



### MENU FUNCTION

MENU ICON	FUCNTION	MENU ICON	FUCNTION
	Address book		Call
	Forward		Missed alarm
	Message		Monitor
	Alarm record		Missed call
	Setting		

#### Functions of the menu icons:

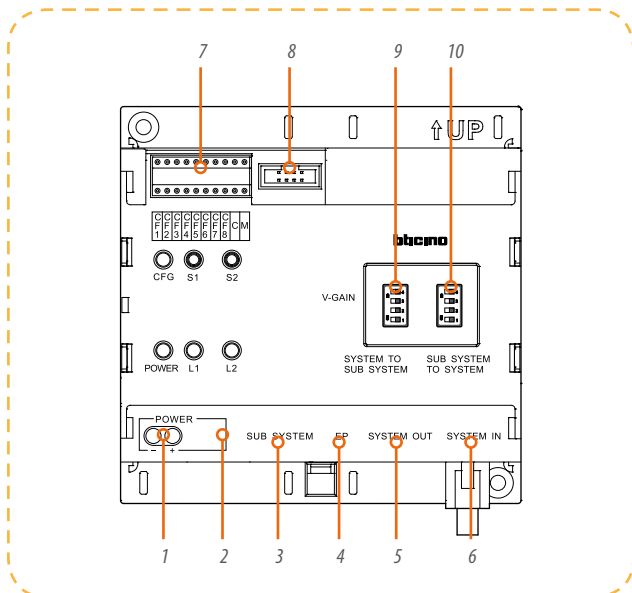
- Address book: use the navigation key to choose this icon, press "OK" to enter address book.
- Call: use the navigation key to choose this icon press "OK" to enter call the interface.
- Function transfer: use the navigation key to choose this icon, press "OK" to enable.  
When the device is not the main MC (address is not 00), it can be set to forward all call to the main MC while unattended. In enable status, do like front, switch to enable status.
- Missed alarm records → enter browser interface, press "△", "▽" keys to check next record. For unprocessed alarms, press "ok" to enter alarm processing interface. After checking and processing the alarms, press "1" or "2" to remove the alarm on MC: "1" means alarm already processed, "2" means false alarm. The MC will send the processing results to the Sf5 software. The MC without alarm will just save alarm record.

- Message record: use the navigation key to choose this icon, press "OK" to enter the message records interface, which includes the following info:
  - Missed call list press "△" and "▽" to browse
  - Answered calls → answered call list press "△", "▽" to browse.
  - Dialled calls → dialled call list press "△", "▽" to browse.
  - Records inspection → abnormal record press "△", "▽" to browse.
  - Enable and disable alarm → record list press "△", "▽" to browse.
  - Delete record → input validating password (default password "888888") → input validating password, then enter the record delete interface: select missed calls and delete by press "OK". All missed call records will be deleted. Follow the same procedure to delete answered calls, dialled calls.
- monitor: use the navigation key to choose this icon, press "OK" to enter the monitoring interface.
- Alarm records: use the navigation key to choose this icon and then press "OK" to enter alarm record interface. Press "△", "▽" key to check the next record. For unprocessed alarms, press "ok" to enter alarm processing interface. After checking and processing the alarms, press "1" or "2" to remove the alarm on MC: "1" means alarm already processed, "2" means false alarm. This device will send the alarm processing results to the Sf5 software. The MC without alarm will just save alarm records. If you need to check the alarm records, press the "\*" key to the search. Now enter the 8-bit HANDSET and press "ok" to check the handset alarm records. Press "△", "▽" key to check the next record.
- Missed calls: use the navigation key to choose this icon, press "OK" to enter the missed calls record interface. Enter the unchecked missed calls interface. The missed calls list will be shown. After checking all missed calls, "00 missed call" will be shown on the MC. Missed call can be browsed in the message record.
- Switchboard parameters setup: use the navigation key to choose this icon, press "OK" to enter the password validating. After entering the correct validating password (default password: 888888), you can enter parameters setup interface using the navigation pushbutton. At present, device can manage several functions. For example can change password, adjust video parameters, short cut key define, polling setup, date & time settings, room mode, addresses book download. It can select device type, local number, language, camera, ring type, riser parameters settings and so on.

# System accessories overview

## 323003 - RISER SHUNT

The riser shunt is used to connect the riser BUS and system BUS in order to separate BUS, transfer signal and switch between video and audio channels. The device has five RJ45 connectors, which are for riser BUS input/ output, system BUS input/ output. The last RJ45 and two other connectors are designed to connect the riser system to the main power supply. The device also has 2 4-gear video gain DIP switches for video channel from the EP to the system BUS, and video channel from the system BUS to the HANDSET. The video transfer distance can be increased by adjusting the gain. By installing several items 323003 in cascade, the riser systems can be connected as a network and managed as districts.



### LEGEND

1. Riser system power supply input connector
2. Riser system power supply input connector
3. Input connector for riser system: SUB SYSTEM IN interface for 323002
4. Entrance panel: riser entrance panel output connector
5. Output connector for SYSTEM OUT BUS: connect the SYSTEM IN interface of next 323003 or 323001 related interface
6. System BUS connector for SYSTEM IN: connect last 323003 SYSTEM OUT interface or leave empty
7. System configurator connector: insert resistor
8. Configuration connector for updating the software and connect the PC in series
9. Adjust switch of video channel gain from the system BUS to the riser handset
10. Adjust switch of video channel gain from the riser entrance panel to the system BUS

Riser shunt



Note: (2 – 6) these five terminals are Rj45 connectors, use a CAT5 cable.

### Indication lights

- CFG: Configuration guide
- POWER: Power supply
- L1 L2: Intercom status
- S1: Confirmation
- S2: Input



The following table indicates the video amplifying gains. During the installation, the parameters need to be adjusted according to image requirements.

### DIP switch setting instruction

	Distance	1	2	3	4
COLOUR VIDEO SIGNAL	0 – 300 m	OFF	OFF	OFF	OFF
	300 – 700 m	ON	OFF	OFF	OFF
	700 – 1000 m	ON	ON	OFF	OFF
B/W VIDEO SIGNAL	1000 – 1500 m	ON	ON	ON	OFF
	1500 – 2000 m	ON	ON	ON	ON

### SYSTEM CONFIGURATION INSTRUCTIONS

The system configuration for the Riser Shunt consists in assigning a number to item 323003, setting the address range managed by item 323003, and selecting the system configuration mode. Only if the configuration is correct can the system work correctly. There are 3 configuration methods. The configurator alternative enjoys the highest priority. If the physical configurator is used on the Riser shunt, then the other configuration methods will be ineffective.

Note: if use physical configurator method is used, the power of item 323003 should be disconnected after the configurator has been installed, and then reconnected to activate the configuration.

## System accessories overview

### 323003 - RISER SHUNT

#### 1. Configuration using physical configurators

There are 3 configuration methods using physical configurators: mode 1, mode 2 and mode 3. The user can choose one of them according to the complexity of the system. The 10th bit is used to mark the mode used. For the details please see the system configuration chapter.

#### 2. Configuration by COM

Use an appropriate cable to connect this device to a PC and enter all the configuration information for this device using the configuration tool installed on the PC.

#### 3. Configuration using the pushbuttons

⊙	⊙	⊙	⊙	⊙	⊙	⊙	⊙	⊙	⊙
<b>CF1</b>	<b>CF2</b>	<b>CF3</b>	<b>CF4</b>	<b>CF5</b>	<b>CF6</b>	<b>CF7</b>	<b>CF8</b>	<b>C</b>	<b>M</b>
⊙	⊙	⊙	⊙	⊙	⊙	⊙	⊙	⊙	⊙

- Enter configuration status: in standby press input key S2 and hold for 2 s. The CFG light will be always on. Enter configuration setup status.
- Enter the configuration number (i.e. select one configurator): press S2 to count. Each pressure will increase the number by one (no press= 1st one) and the CFG light will flash once.
- Confirm the configuration number: press S1, the CFG light flash quickly twice. Then it will come on steady.
- Enter configuration parameter: press S2, the default parameter is 0. Increase by 1 with each pressure. The CFG light will flash quickly twice. The highest number possible is 9.
- Confirm the configuration parameter: press S1, the CFG light will flash quickly twice and then flash slowly twice at the same time. Then the configuration procedure for this step is now completed.
- Set next parameters: if necessary, set the other configuration parameters, press S2. The CFG light will flash quickly 3 times. Then proceed according to (2).
- Complete the configuration: press S1 to exit configuration. The CFG light will be off.
- If the operation is successful, the CFG light will flash slowly once, and then come on steady. If the configuration is not successful, the CFG light will be off.

### FOR EXAMPLE: CONFIGURE CF4 AS 5

1. Enter configuration status: in standby press input key S1 and hold for 2 s.
2. Enter the configuration number: press S2 3 times.
3. Confirm the configurator number: press S1.
4. Enter the configuration parameter: press S2 5 times.
5. Confirm the configuration parameter: press S1.
6. Complete the configuration: press S1 to exit configuration.

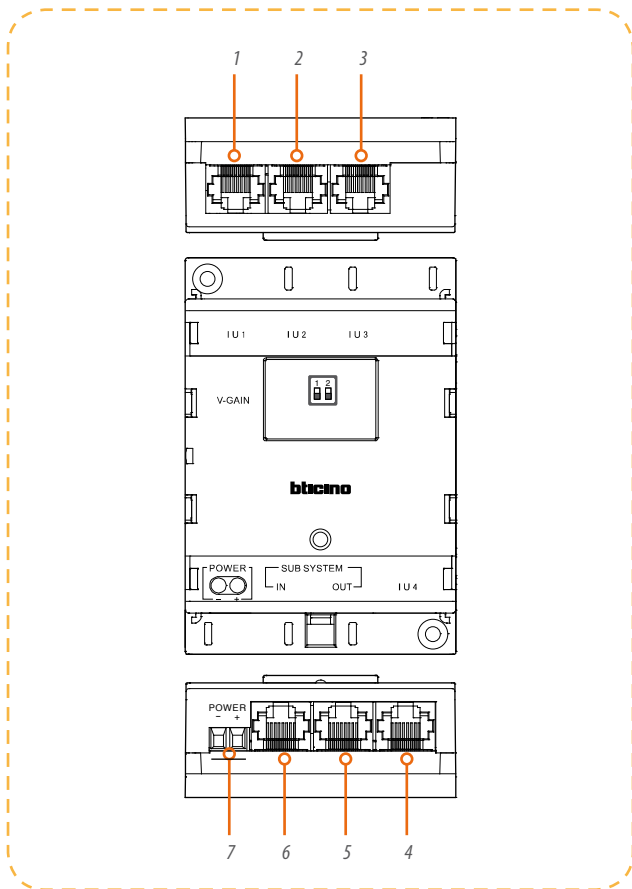
### CONFIGURATION ENQUIRY

1. Enter configuration status: in standby press input key S1 and hold for 2 s. The CFG light will come on and the device will switch to configuration enquiry status
2. Enter the configurator number (i.e. select one configurator): press S2 to count. Each pressure will increase the number by one (no press= 1st one) and the CFG light will flash once.
3. Confirm the configuration parameter: press S1, the CFG light will flash quickly a number of times. This number of times depends on the parameters being read (for example, if the parameter read is 0, there is no flashing, for one it will flash once, for two it will flash twice). Other operations may be deducted by analogy.
4. Exit configuration enquiry status: The CFG light will be off. If no key is pressed for 10 s during the operation the device will automatically switch to standby. The CFG light will be off.
5. If there are 323011 in system or Switchboard be install in riser then need additional configuration in riser shunt as listed below :  
These configuration only can be set by SF2 configuration software or by keyboard.

CONFIGURATION SLOT	Definition	Remark
CF11 CF12	First EP number in this riser	From 1 to 80
CF13 CF14	Riser EP quantity of riser	
CF15 CF16	Riser Switchboard number	From 1 to 15

**323002 - FLOOR SHUNT**

A floor shunt should be installed between floors. Using a signal cable, each apartment handset is connected to the BUS through item 323002. One 323002 can be connected to 4 handsets. The device converts the BUS video signals to transfer mode and then distributes them to the connected handsets.



**LEGEND**

1. Connect four handsets separately;
2. Connect four handsets separately;
3. Connect four handsets separately;
4. Connect four handsets separately;
5. Riser system BUS output connector to connect next 323002 SUB SYSTEM IN connector;
6. Riser system BUS input connector to connect last 323002 SUB SYSTEM OUT connector or 323003 SUB SYSTEM connector;
7. Additional Power supply connector 30 Vdc.

*Note: (1 – 6) these six terminals are RJ45 connectors, use a CAT5 cable.*

Floor shunt



Video gain setting instruction (switch up ON, switch down OFF)



*Note: users can switch the DIP switch to adjust according the actual video conditions.*

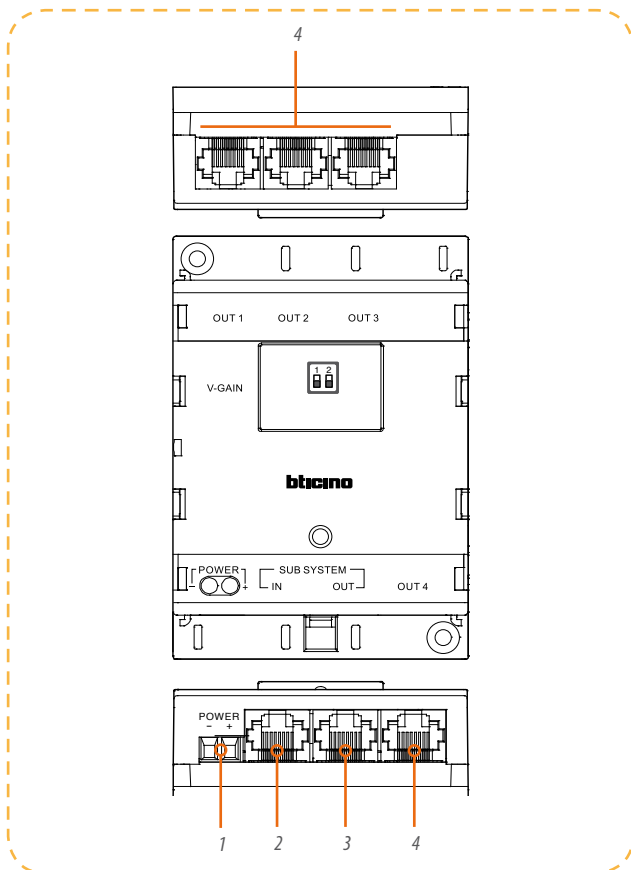
	Distance	1	2
B/W SIGNAL	1000-1500 m	ON	OFF
	1500 - 2000 m	ON	ON

*Note: The instruction data in the above table are suggestions for the B/W signal. They may differ during the actual operation. Irrespective of whether it's a colour (less than 1000m) or B/W signal, please take into account the actual image when setting the data.*

## System accessories overview

### 323016 - VILLA SHUNT

Villa shunt is installed in the public low voltage box in villas areas. The handset of each villa's resident can connect all the signal lines to the bus through the Floor shunt and the Villa shunt. One 323016 can be connected to 4 Floor shunt. If 323002 is connected to 323016, it can only be linked to one house, and only one to three handsets. Device item 323016 can distribute the video signal, audio signal, data signal of the bus to the connected Floor shunt, so that the signals from the unit bus to the Floor shunt can reach a maximum distance of 200 meters, meeting the special requirements of villas.



#### LEGEND

1. DC30V;
2. Auxiliary power connectors: DC30V is the unit system bus input interface, to connect the Riser shunt SUB SYSTEM input interface or the SUB SYSTEM OUT interface of the last Floor shunt;
3. Unit system bus output interface, to connect SUB SYSTEM IN interface of the next floor shunt, or nothing;
4. Connects to 4 floor shunts respectively.

*Note: The six ports from 2) to 7) are all RJ45 interfaces, connected with CAT5 cable.*

Villa shunt



Video gain setting instruction (switch up ON, switch down OFF)



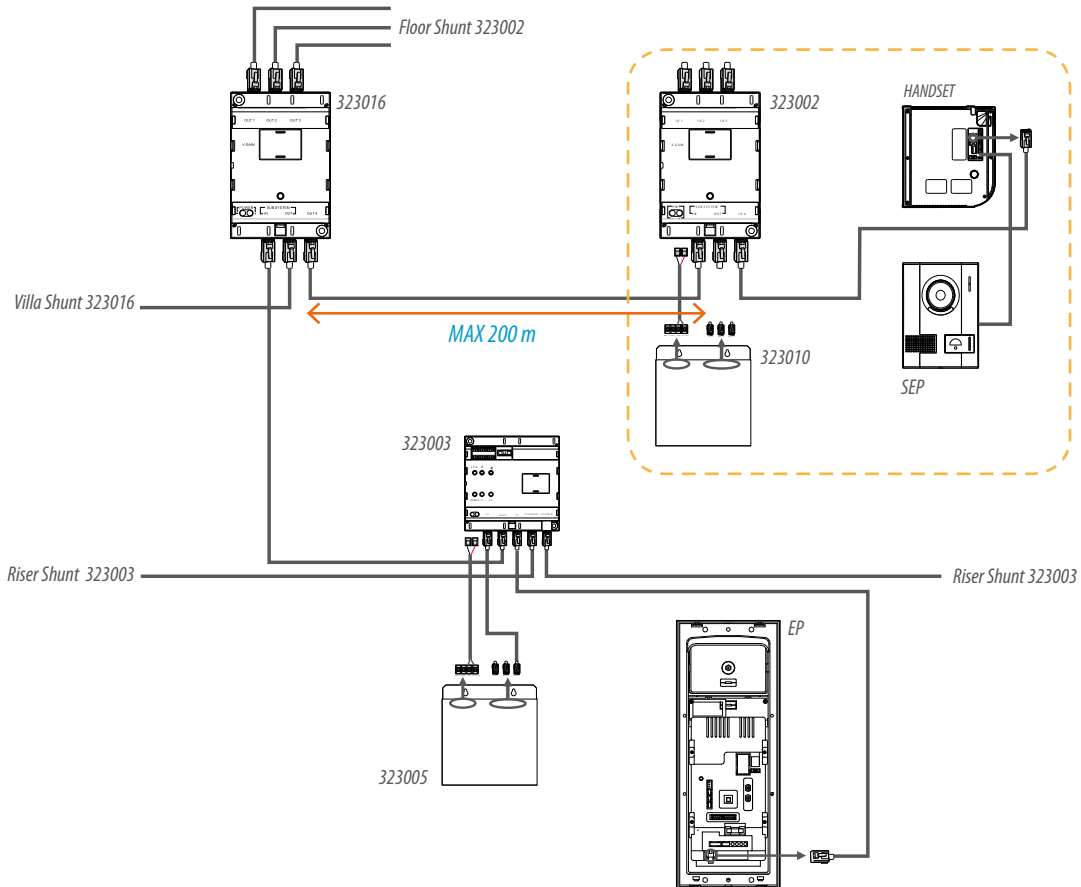
B/W SIGNAL	Distance	1	2
	200 m	OFF	OFF
	200 - 400 m	ON OFF	OFF ON
400 - 500 m	ON	ON	

Directions to the setting of the video-gain switch (up being ON and down being OFF)

*Note: users can turn the switch at any line length and directly verify the setting effect. For details on how to adjust the B/W image, refer to floor shunt specifications.*

**EXAMPLE**

Typical Wiring Diagram of Villa shunt. System wiring diagram for the detached villas.

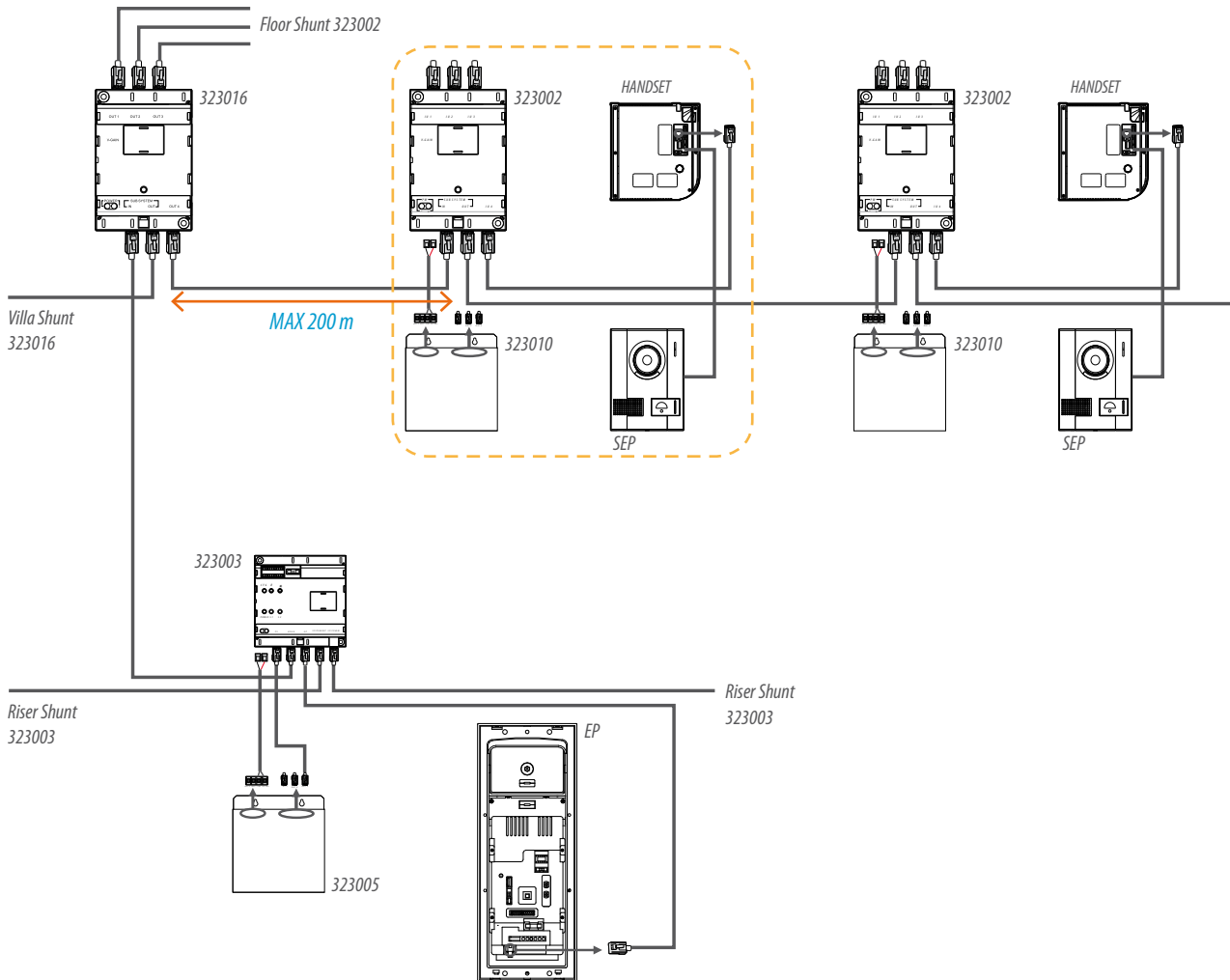


## System accessories overview

### 323016 - VILLA SHUNT

- Power options: You can select the Floor shunt power supply according to the actual power consumption and the distance between Villa shunt and Floor shunt.
- For detached villas without Small EP, if there are 1 to 3 handsets in one villa, then connect each handset to the handset port of Floor shunt. One handset must be set as master and the others as slaves (One Basic Apartment Interface is used to connect several handsets, saving Apartment Interfaces). If there are 4 to 5 handsets in one house, one Apartment Interface should be connected to the HANDSET port for expansion. The Small EP will be connected to the apartment interface, which must be separately powered (as there are many handsets, they need to be powered separately).
- When the detached villa is only fitted with one handset, this can be connected to Floor shunt. If there are 2 to 5 handsets, one Apartment Interface needs to be added for expansion, and the Small EP must be connected to the Apartment Interface.
- The distance between the Villa shunt and the handset must be less than 50 meters and the villa shunt can only be used for one villa.
- The maximum distance between Villa shunt and Floor shunt can reach 200 meters, but on the precondition that the maximum distance from the furthest video source (like main EP) to the furthest video terminal (like HANDSET and management centre) must be 1000 meters for the colour system and 2000 meters for the B&W systems.
- To ensure correct operation of Villa shunt and Floor shunt, their power source must be configured following the software calculation results.

System wiring diagram of town villas.



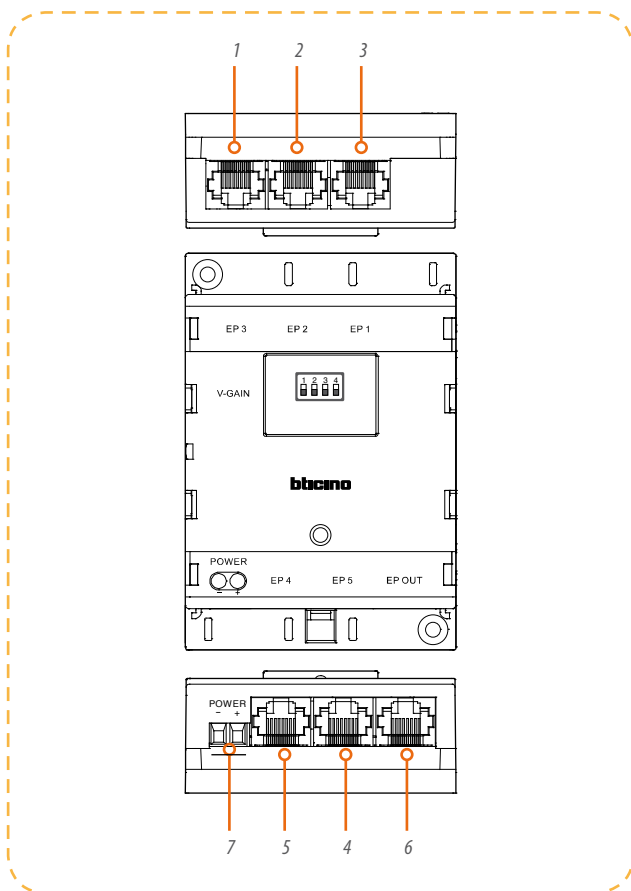
- Power options: You can select the 323010 for 323002 power supply according to the actual power consumption and the distance between Villa shunt and Floor shunt.
- For town villas not fitted with Small EP, if there is 1 handset in each villa, then connect the handset to the Floor shunt. One Floor shunt is used for one house. If there are 2 to 5 handsets in one house, one Apartment Interface should be connected to the Floor shunt HANDSET port for expansion. All the handsets will connect to the Apartment interface, and One Floor shunt must be used for each house.
- For town villas fitted with the Small EP, the installation is just the same as that for the detached villas.
- The distance between the floor shunt and the handset must be less than 50 meters and the floor shunt can only be used for one villa.
- The maximum distance between Villa shunt and Floor shunt can reach 200 meters, but on the precondition that the maximum distance from the furthest video source (like main EP) to the furthest video terminal (like HANDSET and management centre) must be 1000 meters for the colour system and 2000 meters for the B&W systems.
- To ensure correct operation of Villa shunt and Floor shunt, their power source must be configured following the software calculation results.

## System accessories functions overview

### 323004 - ENTRANCE PANELS VIDEO MIXER

The 323004 enables connection of up to 5 entrance panels, providing management of the calls to the riser (the first entrance panel from which the call is made has priority). It is possible to connect in cascade several handsets item 323004.

Video Mixer



DIP switch setting instruction

	Distance	1	2	3	4
COLOUR SIGNAL	0 – 300 m	OFF	OFF	OFF	OFF
	300 – 700 m	ON	OFF	OFF	OFF
	700 – 1000 m	ON	ON	OFF	OFF
B/W SIGNAL	1000 – 1500 m	ON	ON	ON	OFF
	1500 – 2000 m	ON	ON	ON	ON

The instruction data in the above table are suggestions for the B/W signal. They may be different during the actual operation.

#### LEGEND

1. Entrance panels 1, 2, 3, 4, 5: connect to entrance panel output interface 1-5.
6. Entrance panel – OUT: connect the system BUS.
7. Additional Power supply connector, 30 Vdc.

*Note: (1 – 6) these six terminals are RJ45 connectors, use CAT5 cable.*

V-GAIN: Video gain set up.

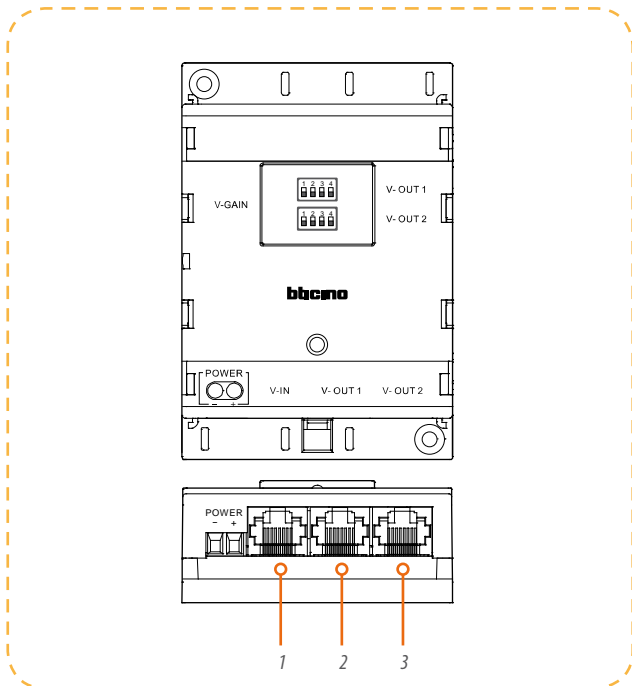
Video gain setting instruction (switch up ON, switch down OFF)



**323007 - 2 BRANCHES VIDEO SPLITTER**

The device has one input and two outputs. It splits the BUS signal into two channels: the video signal can only be transferred from input to output. The video Splitter has 4 gears for video compensation functions. It can provide compensation to two channels separately and make the video signal output from EP adapt to different transfer distances by setting different gears. It mainly use in riser systems to divide the riser BUS into many channels to adapt to the wiring in many low electricity wells. One building that is particularly high will use 323007 to adjust video gains by splitting in two channels. One channel will be used for lower floors, the other is for higher floors. 323007 also can be used for physically connecting the Switchboard and extend the Switchboard interface. (in this case, if the Switchboard is fitted with a camera, the video signal cannot be transmitted to the handset).

2 Branches video splitter



**LEGEND**

- 1. BUS input connector.
- 2. Branch 1 output connector.
- 3. Branch 2 output connector.



DIP switch setting instruction

	Distance	1	2	3	4
COLOUR SIGNAL	0 – 300 m	OFF	OFF	OFF	OFF
	300 – 700 m	ON	OFF	OFF	OFF
	700 – 1000 m	ON	ON	OFF	OFF
B/W SIGNAL	1000 – 1500 m	ON	ON	ON	OFF
	1500 – 2000 m	ON	ON	ON	ON

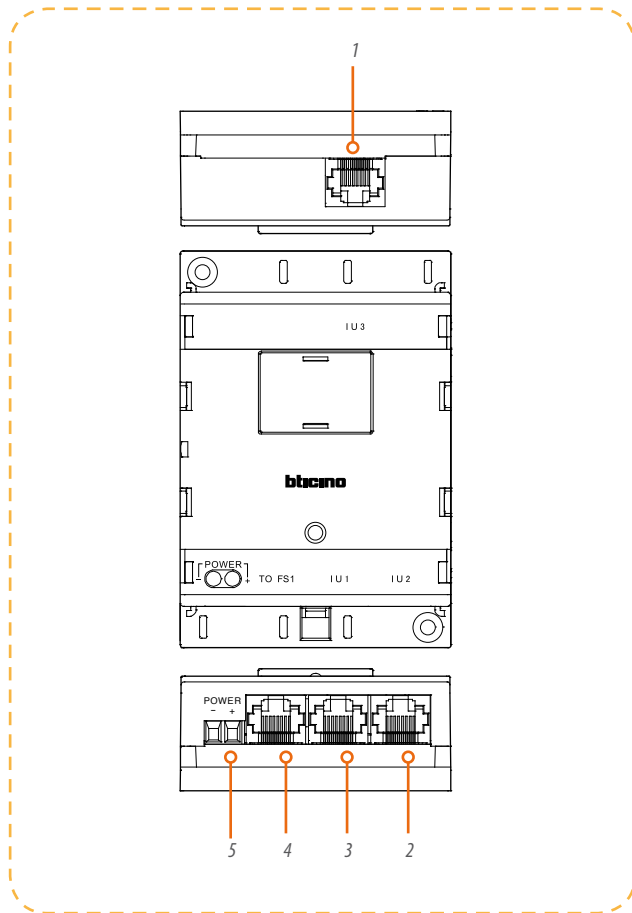
The instruction data in above table may be different during actual installation.

## System accessories functions overview

### 323008 - BASIC APARTMENT INTERFACE

323008 should be installed between Floor shunt and handset. When one apartment has 2 or 3 handsets, please use this device to extend interfaces.

Basic apartment interface



### LEGEND

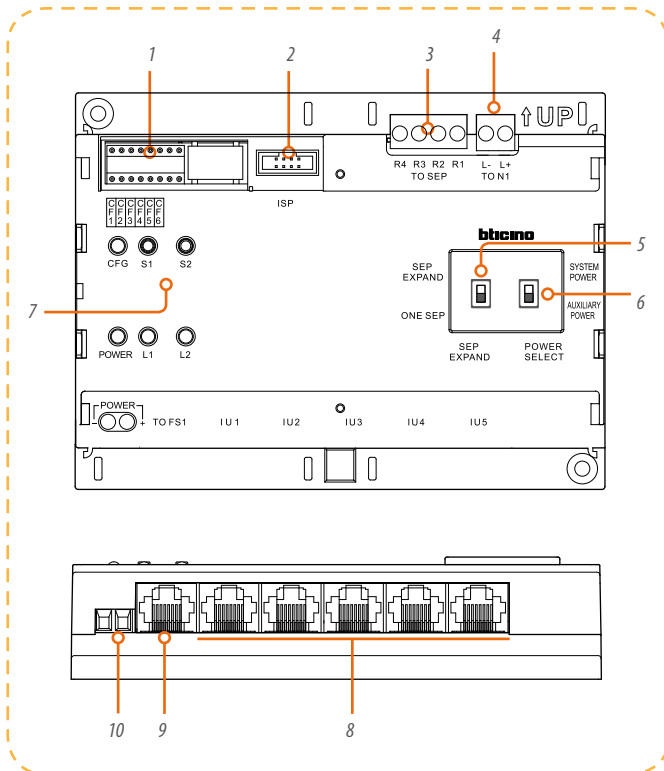
1. Connector for handset 3
2. Connector for handset 2
3. Connector for handset 1
4. System BUS input
5. Accessory power supply input 30 Vdc

Note: (1 – 4) these four terminals are RJ45 connectors, use CAT5 cable.

**323009 - APARTMENT INTERFACE**

This device is installed inside the house of the user and is used for expanding handsets and Small EP. One Apartment interface can connect 5 handsets and one Small EP, performing the necessary functions for calling the handsets and calling and monitoring Small EP.

Apartment interface



**LEGEND**

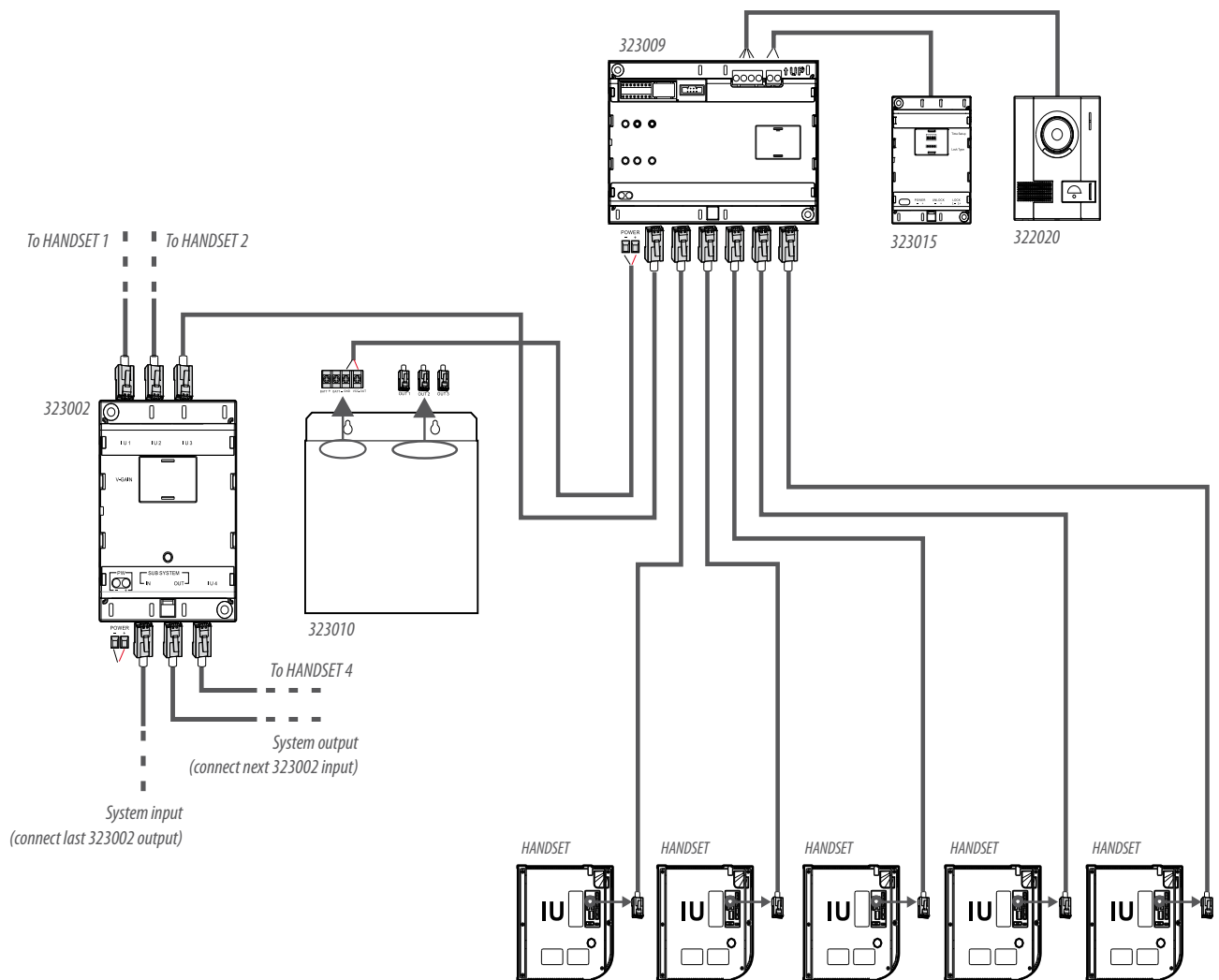
1. Configurators housing
2. Serial interface connector for PC configuration and firmware update
3. Analogue small entrance panel connections
4. Electrical door lock connector
5. Small entrance panel expansion microswitch setting (factory set to DOWN position)
  - SWITCH UP position = enable multi gate interface expansion
  - SWITCH DOWN position = only one gate enabled
6. Power supply source selection switch :
  - SWITCH UP position = system power supply power source enabled
  - SWITCH DOWN position = auxiliary power supply source enabled
7. S1 - S2 Manual device configuration pushbuttons (NOT USED)
8. IU1 to IU5 RJ45 Indoor handsets connectors
9. RJ45 floor shunt connector
10. Auxiliary power supply input connector (30 V)

## System accessories functions overview

### 323009 - APARTMENT INTERFACE

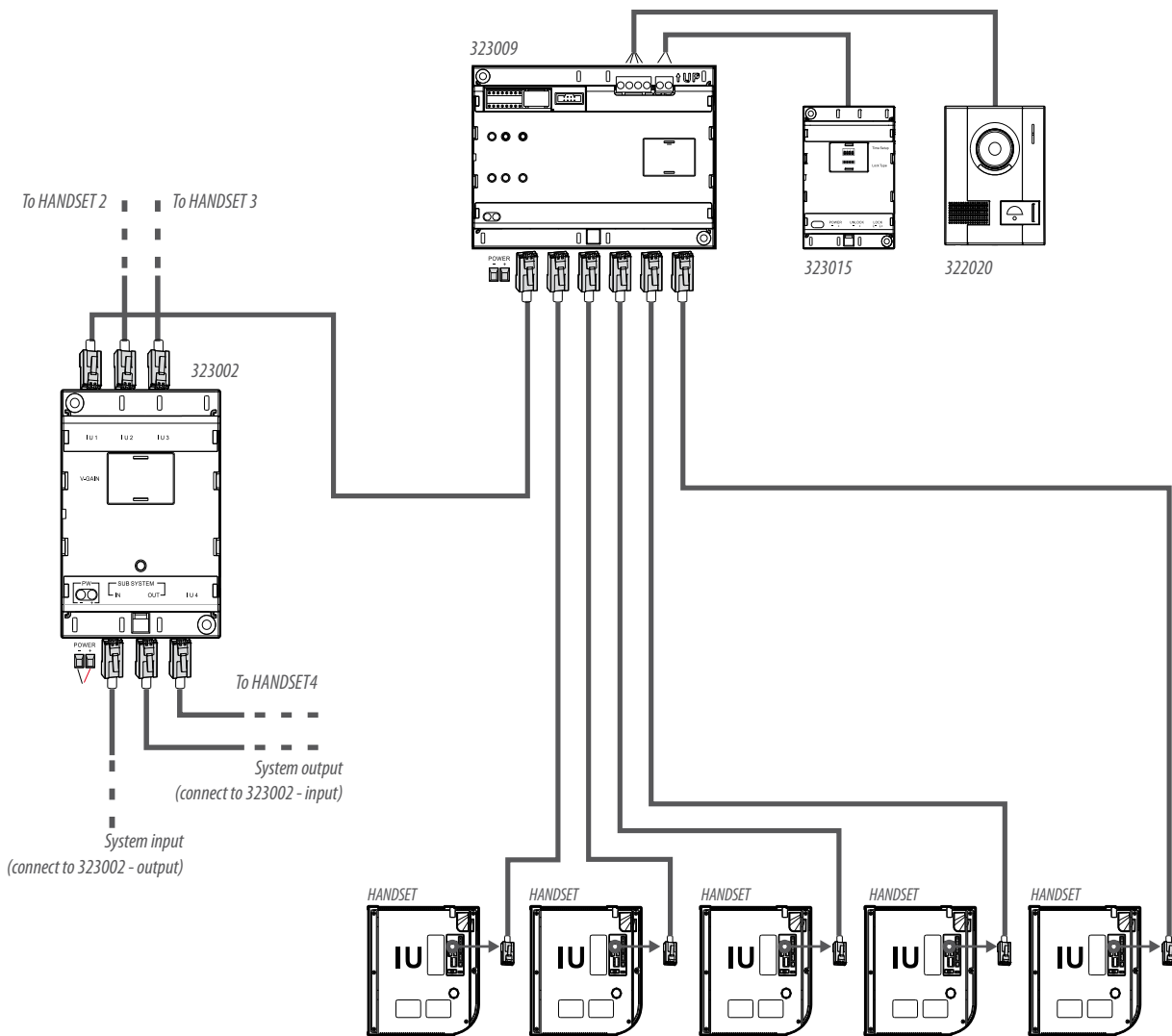
#### Typical Wiring Diagram 1

Remarks. To power this device you can either use the auxiliary power supply or the standard power supply (We recommend using the auxiliary Power supply). If the power consumption of five handsets is not more than the supply provided by one power supply, then these five handsets can all be set as the master handsets.



*Typical Wiring Diagram 2*

Remarks: If powered through the unit bus system, only one indoor unit can be set as the master indoor unit.

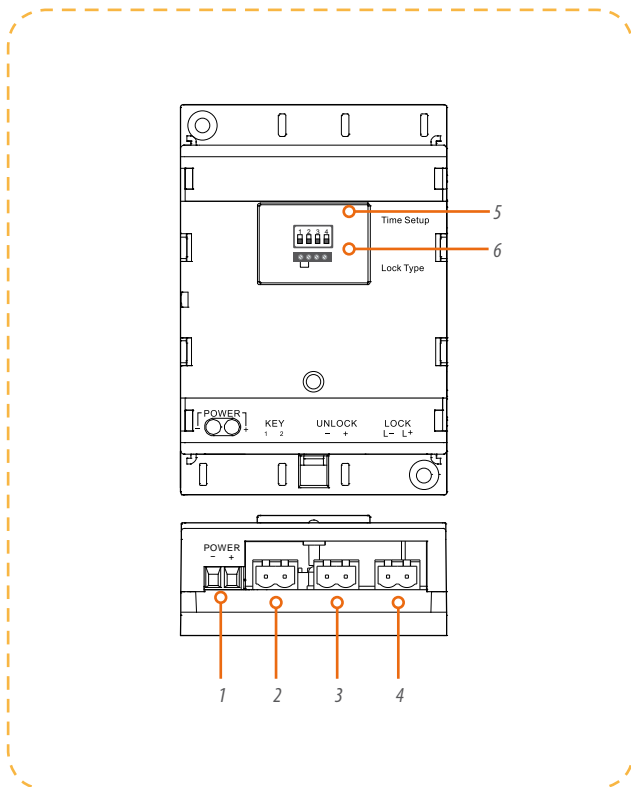


## System accessories functions overview

### 323015 - DOOR LOCK ACCESSORY

323015 accessory is an electric door lock driver, used to control the commonly used 12 V negative locks. When the Positive locks' opening current is over 1 A, the device is also needed to drive positive locks. It's generally connected with the EP to get the door lock release control signal. The Door lock can also be released by means of an external manual switch. You can select the type of electric door lock control through the jumper line configuration. When used to drive the negative locks, device can drive two negative locks at most. The device also has a time delay function with 4 time delay steps, which can meet different types of needs.

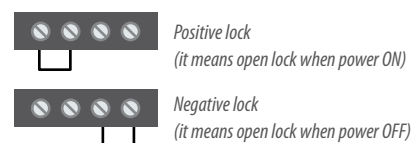
Door lock accessory



STATUS				
TIME DELAY	5 S	10 S	15 S	20 S

Select the jumper line for the electric door lock release types

#### 6. Door lock release type



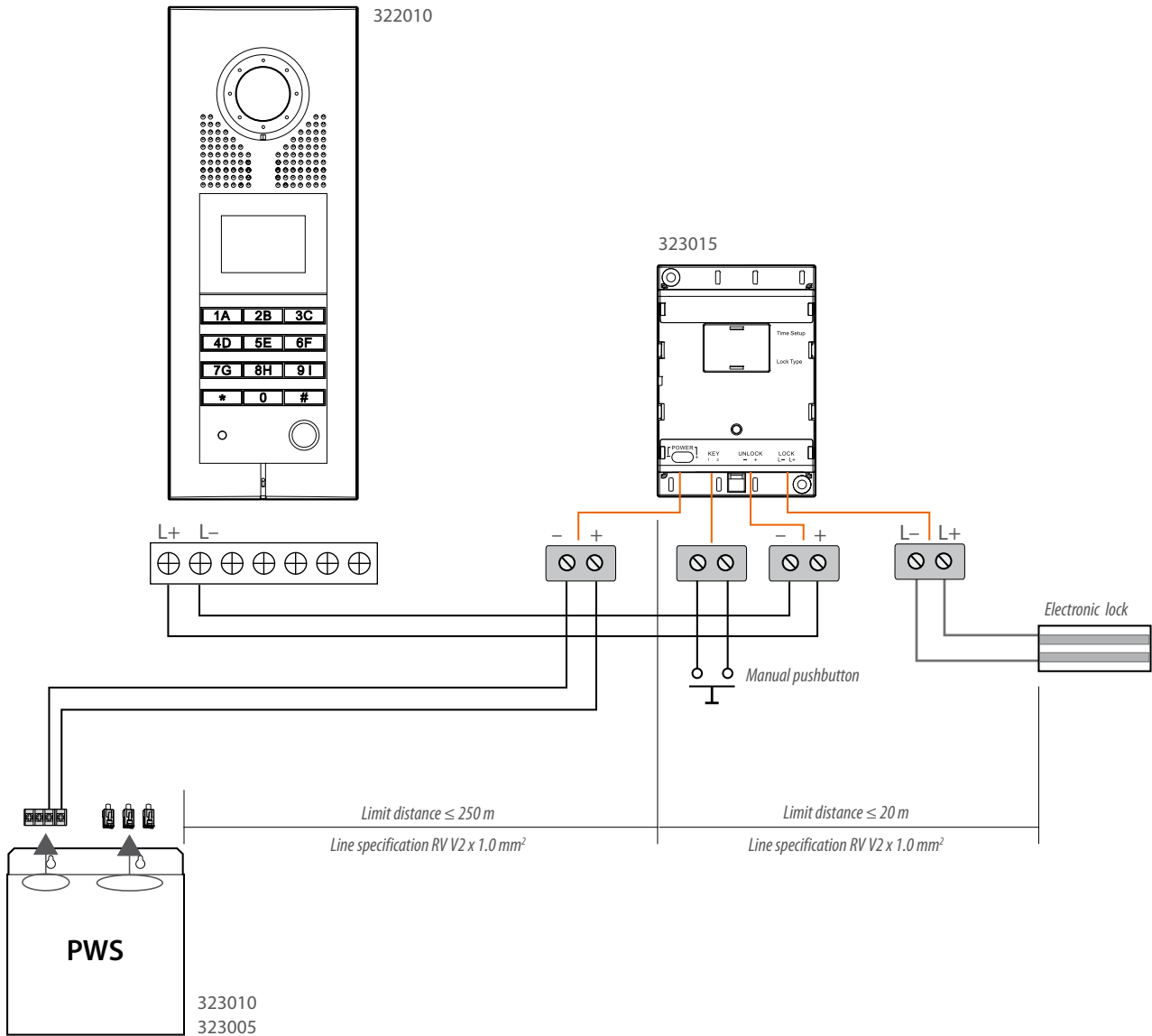
(Positive Lock) Drives the positive lock  
(Negative Lock) Drives the negative lock

*Note: The factory default is negative locks. The device can drive two negative door locks at the same time.*

#### LEGEND

1. Power input end: to DC15~30V drive positive locks; to DC18~30V drive negative locks
2. External manual door lock release switch
3. Input end of the control signal, it can connect the door lock release signal of EP or the door lock release signal of the handset .
4. Connect the negative or positive locks. When connecting the negative locks, it can control two negative locks maximum at the same time.
5. Setting switch for the door lock release time delay, only valid for the negative locks.

Example: Typical Wiring of the door lock accessory



Note: the above power supply belongs to the unit system power and is commonly used with the Riser shunt, if there are no other requirements. Users can also connect an external DC18V~30V/2A power transformer for separate door lock accessory power supply. Device item 323010 is the auxiliary power supply for

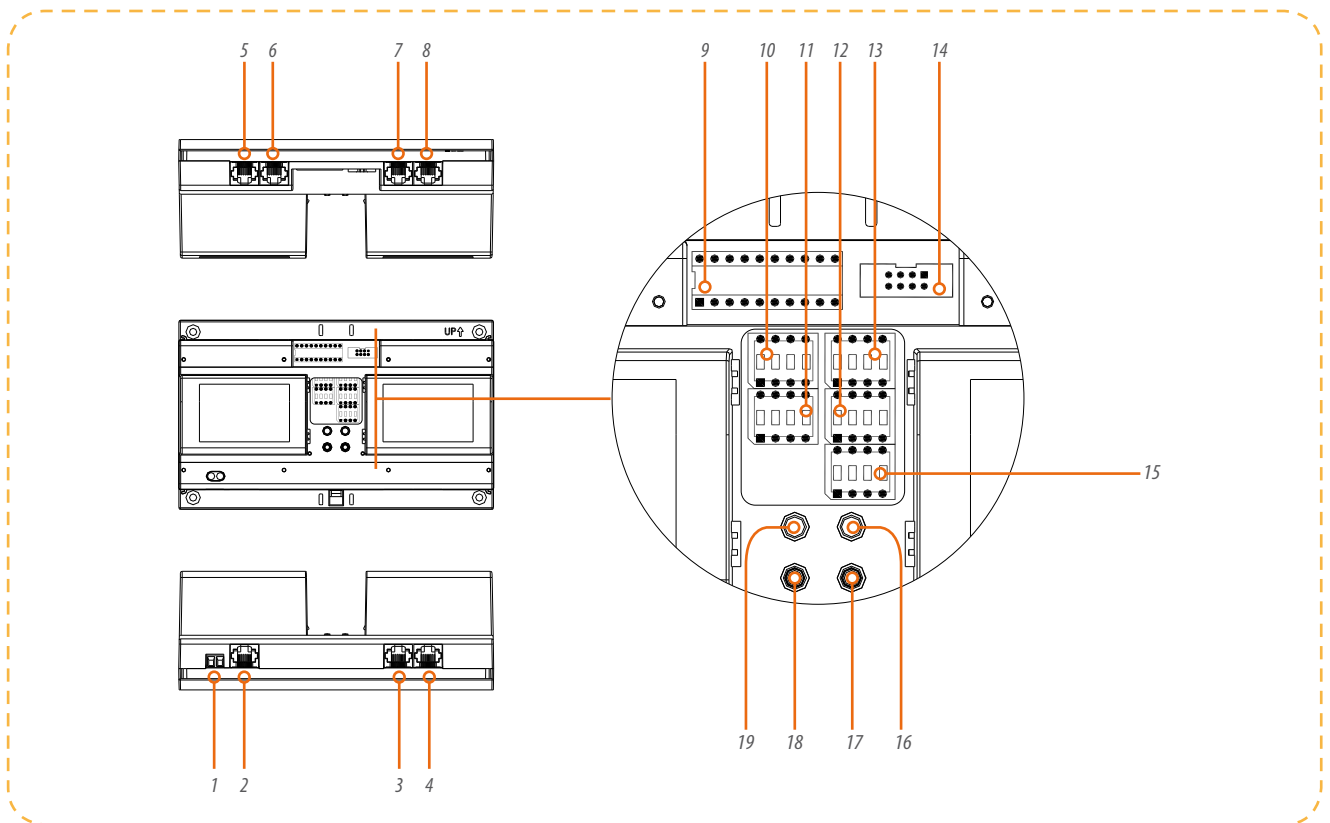
the EP (sometimes, when there are several EPs in one unit, or if the main EP lines are too long, auxiliary power sources are needed). The door lock accessory can either be connected to this power source or to the external DC18V~30V/2A power transformer.

## System accessories functions overview

### 323013 - DISTRICT GENERATOR

323013 is the district hub that can be connected with 4 district riser shunts, 1 wall EP connector, 1 Switchboard connector and 1 main system power connector. It's used to create large networks. Can be connected in cascade to extend to 16 district branches. The maximum level of cascade connection is 1. When installed as part of the system, the device controls and changes video channel, and provides amplifying compensation for video signal. The video gains of each Riser shunt district branch can be set separately.

District generator



#### LEGEND

- |   |   |
|---|---|
| <ul style="list-style-type: none"> <li>1. POWER: Input connector main system power supply</li> <li>2. POWER: Input connector main system power supply</li> <li>3. Switchboard: Connector for Switchboard</li> <li>4. Main EP: Connector for wall EP</li> <li>5. D1: Riser shunt branch 1</li> <li>6. D2: Riser shunt branch 2</li> <li>7. D3: Riser shunt branch 3</li> <li>8. D4: Riser shunt branch 4</li> <li>9. Configurators socket</li> <li>10. Adjust switch for branch 2 video gain</li> <li>11. Adjust switch for branch 1 video gain</li> <li>12. Adjust switch for branch 4 video gain</li> <li>13. Adjust switch for branch 3 video gain</li> </ul> | <ul style="list-style-type: none"> <li>14. Serial interface connector for upgrading the software and connecting the PC</li> <li>15. Adjust switch for WEP or message release to indoor unit channel video gain</li> <li>16. CFG: Indicator light for configuration by pushbutton</li> <li>17. S2 Key</li> <li>18. S1 Key</li> <li>19. POWER: Indicator light</li> </ul> |
|---|---|

The video gain setting can be divided into 5 branches, branch1, branch 2, branch 3, branch 4, wall EP, or release message to handset channel. They can all be set according to the instruction data in following table. However, these data may be different during actual installation. To adjust and set the data take into account the actual image.



**DIP switch setting instruction**

	Distance	1	2	3	4
<b>COLOUR SIGNAL</b>	0 – 300 m	OFF	OFF	OFF	OFF
	300 – 700 m	ON	OFF	OFF	OFF
	700 – 1000 m	ON	ON	OFF	OFF
<b>B/W SIGNAL</b>	1000 – 1500 m	ON	ON	ON	OFF
	1500 – 2000 m	ON	ON	ON	ON

**SYSTEM CONFIGURATION INSTRUCTIONS**

Only if the configuration is correct can the device work correctly. District generator system configuration includes District generator level mode; dial address of the Switchboard managed by District generator etc. The District generator can be configured in three ways. The configurator alternative has the highest priority. If configurator method is used, the other method will not work. Note: When the configurator method is used, after the procedure disconnect and reconnect the power to activate the configuration.

1. resistor configuration method.  
There is only one configuration method using the configurator. For the details please see the system configuration chapter.
2. Pushbutton method ( only effective when the resistor configuration method is not used)

⊙	⊙	⊙	⊙	⊙	⊙	⊙
<b>EPS</b>	<b>EPS</b>	<b>MC min</b>	<b>MC min</b>	<b>MC max</b>	<b>MC mac</b>	<b>P/S</b>
⊙	⊙	⊙	⊙	⊙	⊙	⊙

1. Enter configuration status: in standby press input key S2 and hold for 2 s. The CFG light will be always on. Enter the configuration setup status. (If there is a resistor configurator installed or if the pushbutton configuration has been performed incorrectly, the device cannot enter configuration setup status.

2. Enter the configuration number (select which place): press S2 to count. Each pressure will increase the number by one (no press= 1st one) and the CFG light will flash once.
3. Confirm the configurator number: press S1 then CFG light flash quickly twice. Then it will come on steady.
4. Enter the configuration parameter: press S2, the default parameter is 0. Increase by 1 with each pressure. The CFG light will flash quickly twice . The highest number possible is 9.
5. Confirm the configuration parameter: press S1, the CFG light will flash quickly twice and then flash slowly twice. Then the configuration procedure for this step is now completed.
6. Set the next parameters: if necessary, set the other configuration parameters, press S2. The CFG light will flash quickly 3 times. Then proceed according to (2).
7. Complete the configuration: press S1 to exit configuration. The CFG light will be off.

If the operation is successful, the CFG light will flash slowly once. Restart to activate the new configuration. If the configuration is not successful (for example, one configuration exceeds the acceptable value, e.g. P/S>1), the CFG light will be off, and the old configuration will be still effective. If the configuration value has logical errors (for example, EPS>80 or MC Min > MC Max), after restart the CFG light will keep flashing slowly to indicate the error and pushbutton operation will be disabled. In this case it will be necessary to connect a non-zero (1- 9) configurator to the right position (from the 1st to the 7th position of the configurator) and reconnect the power to clear the pushbutton configuration. Then remove the configurators, reconnect the power and repeat the above configuration steps. If no pushbutton is pressed for 10s during the operation, the device will automatically exit configuration mode and the CFG light will go off.

**CONFIGURATION INQUIRY:**

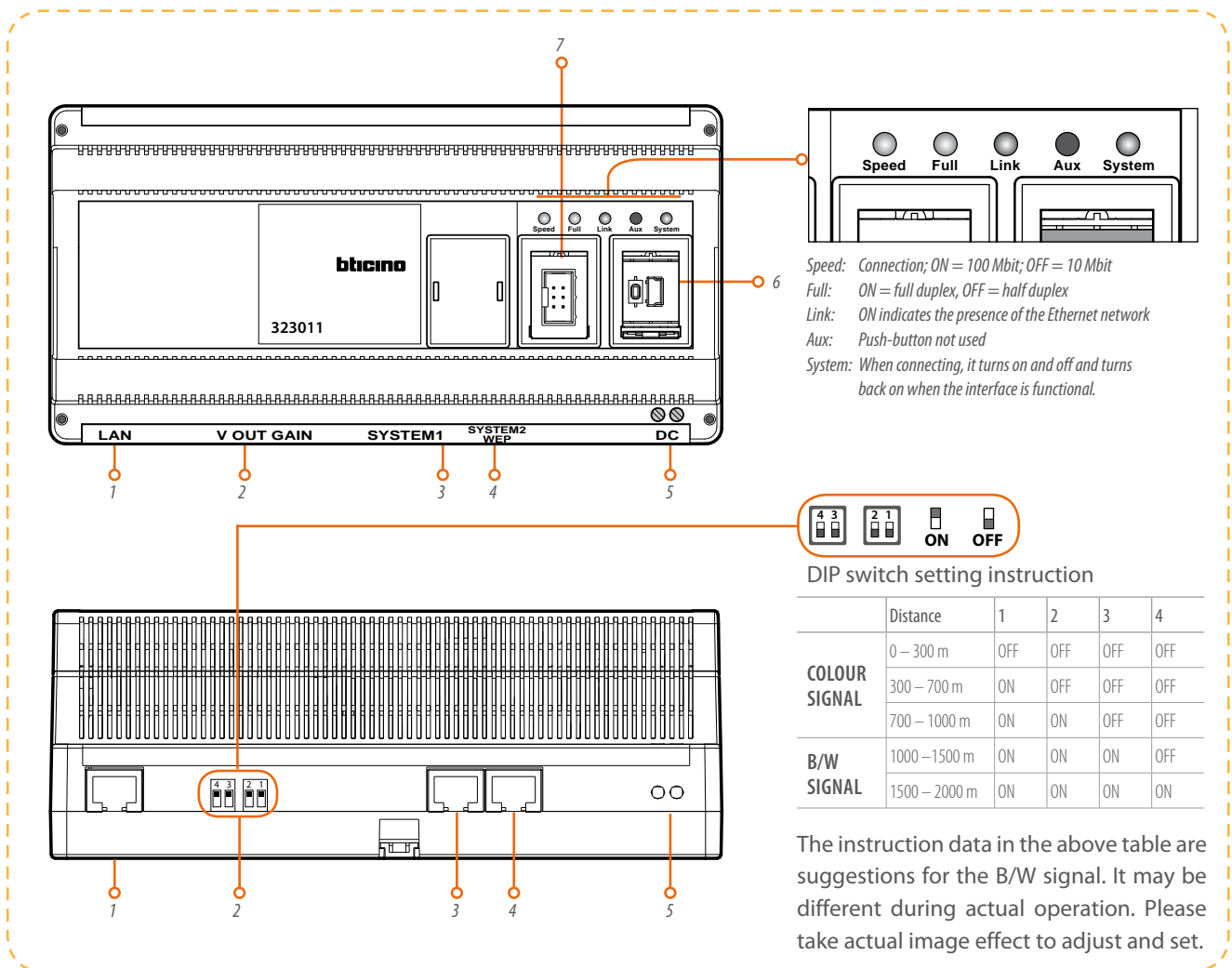
1. Enter configuration enquiry status: in standby press input key S1 and hold for 2 s. The CFG light will come on and the device will switch to configuration enquiry status.
2. Enter the configurator number (i.e. select one configurator): press S2 to count. Each pressure will increase the number by one (no press= 1st one) and the CFG light will flash once.
3. Confirm the configuration parameter: press S1, the CFG light will flash quickly a number of times. This number of times depends on the parameters being read (for example, if the parameter read is 0, there is no flashing, for one it will flash once, for two it will flash twice, and so on for the others (4). Exit configuration enquiry status: The CFG light will be off. If no key is pressed for 10 s during the operation the device will automatically switch to standby. The CFG light will be off.

# System accessories functions overview

## 323011 - D45/IP INTERFACE

323011 is an IP interface that can be connected to the D45 system and the BT 2-wire IP system. It ensures compatibility with the D45 system and BT 2-wire system.

D45/IP interface

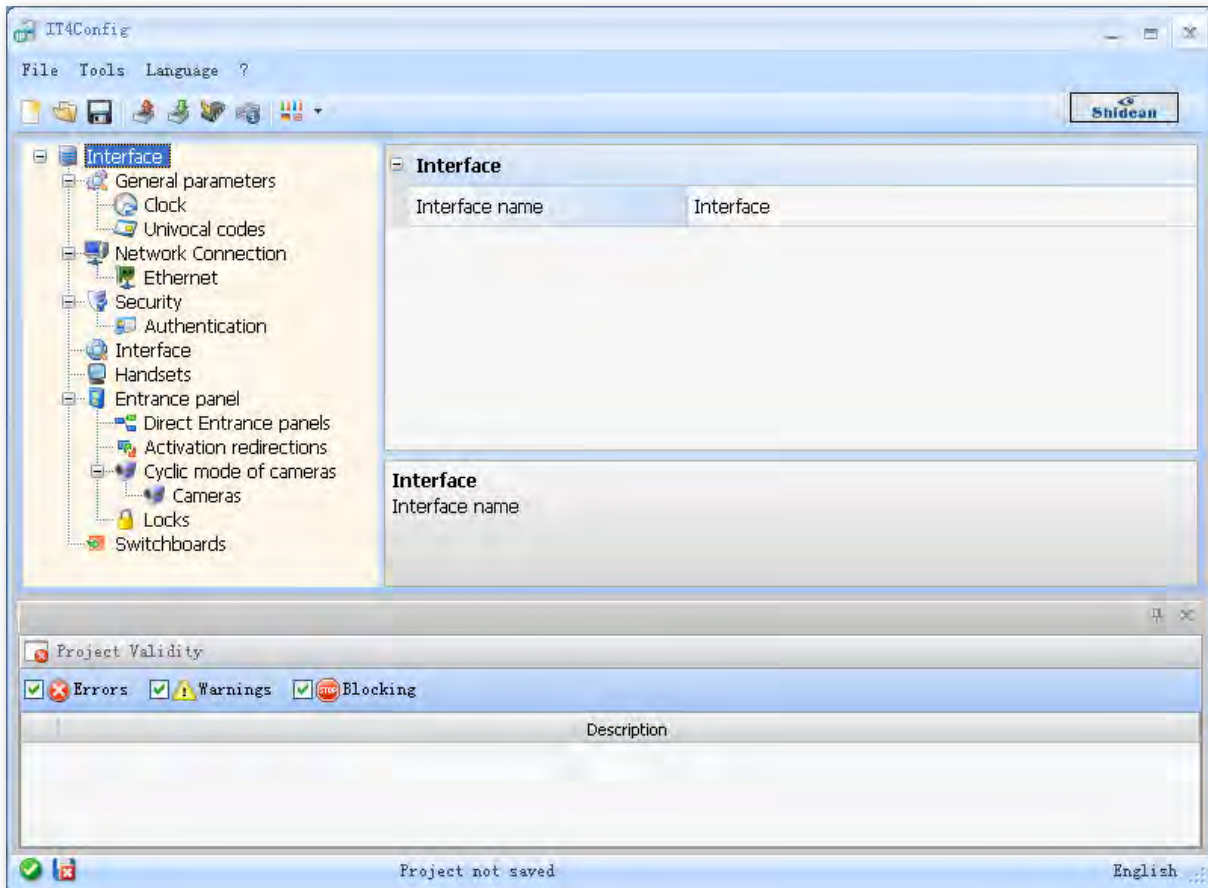


### LEGEND

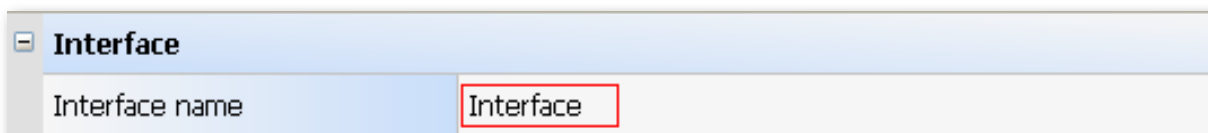
1. LAN: network interface, used to connect the Ethernet to the system network. It can also download the configuration, read the configuration and update the programs through the Ethernet.
2. V-OUT GAIN: switch to adjust the video gains, which can be adjusted as per the actual video effect.
3. SYSTEM 1: system bus interface 1, to connect to the Riser shunt.
4. SYSTEM 2/main EP: system bus interface 2, used to connect the main EP.
5. DC: 30V power input port, no positive or negative difference.
6. USB interface: used to download the configuration, read the configuration and update the programs.
7. Serial port: used to download the configuration, read the configuration and update the programs.

### 323011 CONFIGURATION

The device can't work unless configured before use with the special-purpose configuration software D45/IP interface Config 3.0. Its operating environment needs the support of Microsoft NET3.5, which means that before installing the D45/IP interface Config 3.0, NET3.5 must be installed. After installing the D45/IP interface Config 3.0, it can be run. The interface is shown below:



Select the "INTERFACE" node at the left of the main interface and input the name of the D45/IP interface into the red box at the right. The users can either input a name that can be easily remembered, such as D45/IP interface-1, or can use the default name.



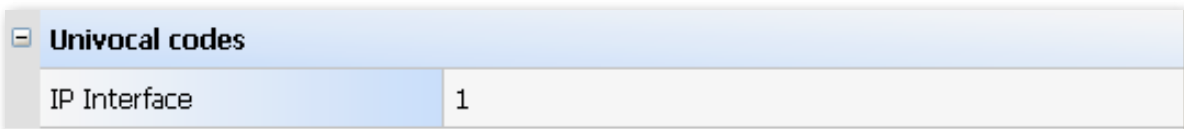
## System accessories functions overview

### 323011 - D45/IP INTERFACE

Select the "CLOCK" node on the left of the main interface. The Time Zone option on the right is used for selecting the time zone, which can also use the default value. The default working mode option is used to select the clock working mode of 323011: Slave mode (a subordinate passive mode of accepting the time), or Master mode (an active mode where the clock can be set), can be used as the default value. The date format option is used to select the date format. The default value can be used.



Select the "UNIVOCAL CODE" node at the left of the main interface and input in the only identification code into the IP interface. The range is 1~100000, with no code repetition in the same project allowed.



Select the "ETHERNET" node on the left of the main interface. The Addressing type option on the right is used to select the distribution IP addresses distribution mode. Select Dynamic IP and you get dynamic IP distribution, for which the network requires a router (the DHCP function needs to be started), or the DHCP server can dynamically distribute an IP address for the D45/IP interface. Or you can select the Fixed IP mode, which is a manual IP configuration mode. In this mode the addresses can be configured manually:

- the IP address will be used to configure the IP address of item 323011, defaulted at 192.168.1.100. Please configure the IP address based on the actual system situation, which is suggested as 192.168.1.X. (Note: No repetitions in the same system).
- Subnet mask: it's used to configure the subnet mask, defaulted at 255.255.255.0. Please configure the subnet mask based on the actual IP configuration, but generally adopting the default value.
- IP router: it's used to configure the IP of the router in the configuration system. It's suggested that you just use the IP address of the management centre computer (the management centre computer uses 192.168.1.1).
- Primary DNS: it's used to configure the IP address of the first domain name analysis server. It's suggested that you just use the IP address of the management centre computer.
- Secondary DNS: it's used to configure the IP address of the second domain name analysis server. It's suggested that you just use the IP address of the management centre computer.

Ethernet	
Addressing type	Dynamic IP
IP Address	192.168.1.100
Subnet Mask	255.255.255.0
IP Router	192.168.1.1
Primary DNS	192.168.1.1
Secondary DNS	192.168.1.1

Select the “AUTHENTICATION” node on the left of the main interface and the Password option on the right will be used to input in the password for the 323011 to download the configuration. The default password is 12345. It’s suggested to still use this password for later maintenance.

Authentication	
Password	12345

Select the “INTERFACE” node on the left of the main interface. The Handsets under the option of Base address will be used to configure the base address of handset 323011, which can just use the default value 0. Entrance panel is used to configure the base address of the EP’s D45/IP interface, which can also use the default value of 0. Handsets under the Callout base address option will be used to configure the base address of the handset callout at 323011, which can just use the default value of 0.

Base address	
Handsets	0
Entrance panel	0
Callout base address	
Handsets	0

Select the “HANDSETS” node on the left of the main interface, and then look at the interface on the right, The handset presence option will be used to select whether the 323011 connects the handset or not (namely whether D45/IP interface is the resident Riser). If yes, please select Yes; if it’s only used to connect the backbone, select NO. On selecting No, the Lower address, Higher address, and system address range will become grey, which means that they cannot be set. The Lower address option is used to input in the lowest address (range 0 to 3999. It must be smaller than the higher address) that connects item 323011 to the handset. The Higher address option is used to input in the highest address (range 0 to 3999. It must be higher than the lower address) that connects item 323011 to the handset. The system address range displays the address range of the handset set for the above two options.

**EXAMPLE:**

If the first D45/IP interface 1 connects 3 Risers (Riser 1, Riser 2 and Riser 3), the second D45/IP interface 2 will connect 4 Risers (Riser 4, Riser 5, Riser 6 and Riser 7). Each Riser should be configured as per Mode 1

SET THE HANDSETS OPTION OF D45/IP INTERFACE 1				
Riser Serial number	Each Riser address range	Lower address	Higher address	323011 address range
Riser 1	0 - 79	0	239	0-239
Riser 2	80 - 159			
Riser 3	160 - 239			
Set the handsets option of D45/IP interface 2				
Riser serial number	Each Riser address range	Lower address	Higher address	323011 address range
Riser 4	240-319	240	559	240-559
Riser 5	320-399			
Riser 6	400-479			
Riser 7	480-559			

## System accessories functions overview

### 323011 - D45/IP INTERFACE

The Autoignition option uses the default value of Switchboard autoignition.

<b>Handset address range</b>	
Internal unit presence	<input checked="" type="checkbox"/> Yes
Lower address	0
Higher address	3999
System address range	[0;3999]
<b>Autoignition</b>	
Switchboard autoignition	<input checked="" type="checkbox"/> Switchboard autoignition

The Entrance panel presence option is used to select whether D45/IP interface connects to the main Backbone/Main EP or EP. If so, please select Yes, or if it's only used to connect a Riser and there is no EP in the unit, then select NO. On selecting No, the Lower address, Higher address, and system address range will become grey, which means that they cannot be set. The Lower address option is used to input in the lowest address (range 1 to 80. It must be smaller than the higher address) used by interface D45/IP to connect the main Backbone to the Main EP or EP.

The Higher address option is used to input in the highest address (range 1 to 80. It must be higher than the lower address) used by interface D45/IP to connect the main Backbone to the Main EP or EP. The system address range displays the Backbone/Main EP or EP address range set for the above two options.

Remarks. With D45/IP interface as part of the network, the Switchboard must use SF4, when the distribution address for Backbone/Main EP and EP may be different from that used for a floor shunt. When using IT1 and the floor shunt, the EP address range is 1 to 80, and so is the EP. But when using 323011 and EP jointly use the same address section, namely that main EP+EP address range is 1 to 80 (All the main EPs and EPs in the system are identified with line address from 1 to 80 that can't be repeated).

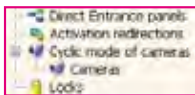
### EXAMPLE

If the first D45/IP interface 1 connects 2 main EPs and 3 Risers (Riser 1, Riser 2 and Riser 3), then each Riser will be connected to one EP. If the second D45/IP interface 2 connects 0 main EP and Risers (Riser 4, Riser 5 and Riser 6), then Riser 4 and Riser 6 are connected to 1 EP and Riser 5 is connected to 2 EPs:

				SET THE ENTRANCE PANL OPTION UNDER D45/IP INTERFACE 1	
Device	Locally set address	Configure EP deviation address on 323003	Relevant system address	Lower address	Higher address
The 1 <sup>st</sup> main EP	1	—	1	1	5
he 2 <sup>nd</sup> main EP	2	—	2		
Riser 1 EP	1	2	1+2=3		
Riser 2 EP	1	3	1+3=4		
Riser 3 EP	1	4	1+4=5		
				THE ENTRANCE PANEL OPTION UNDER D45/IP INTERFACE 2	
Device	Locally set address	Configure EP deviation address on 323003	Relevant system address	Lower address	Higher address
Riser 4 EP	1	5	1+5=6	6	9
The 1 <sup>st</sup> EP of Riser 5	1	6	1+6=7		
The 2 <sup>nd</sup> EP of Riser 5	2		2+6=8		
Riser 6 EP	1	8	1+8=9		

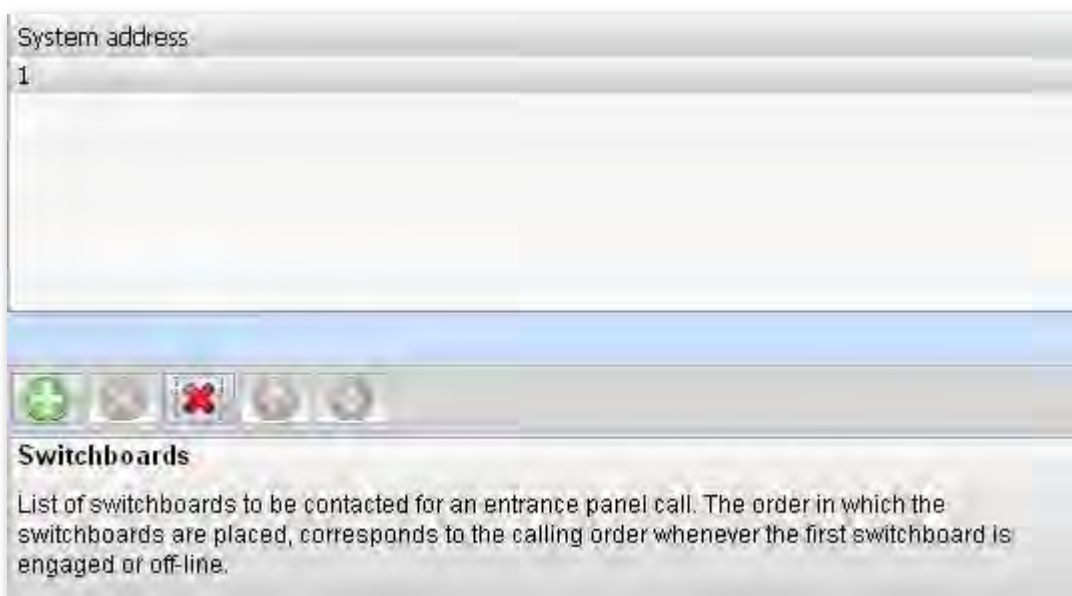
It's suggested to select the default value, "No forwarding" for the "Call forward" option.

<b>Entrance panel address range</b>	
Entrance panel presence	<input checked="" type="checkbox"/> Yes
Lower address	0
Higher address	95
System address range	[0;95]
<b>Call management</b>	
Call forward	No forward



Select the "Direct Entrance panels" node on the left of the main interface and use the default value for the setting.

Select the "SWITCHBOARD" node on the left of the main interface. the interface on the right will be as follows. If the project includes a Switchboard, press the "+" key to add the address of the management centre directed by the D45/IP interface, which will be defaulted at 1. If the actual address of the management centre is not set to 1 (it's recommended that it is 1), then you can modify and input in the actual address. With several management centres, you can add addresses by pressing the "+" key and input in the correct ones. By using the "↑↓" key, you can sort an address list for the several management centres. Sorted at the top is the D45/IP interface that takes priority to call the management centre. If busy, it will be automatically transferred to the other management centres following the list.

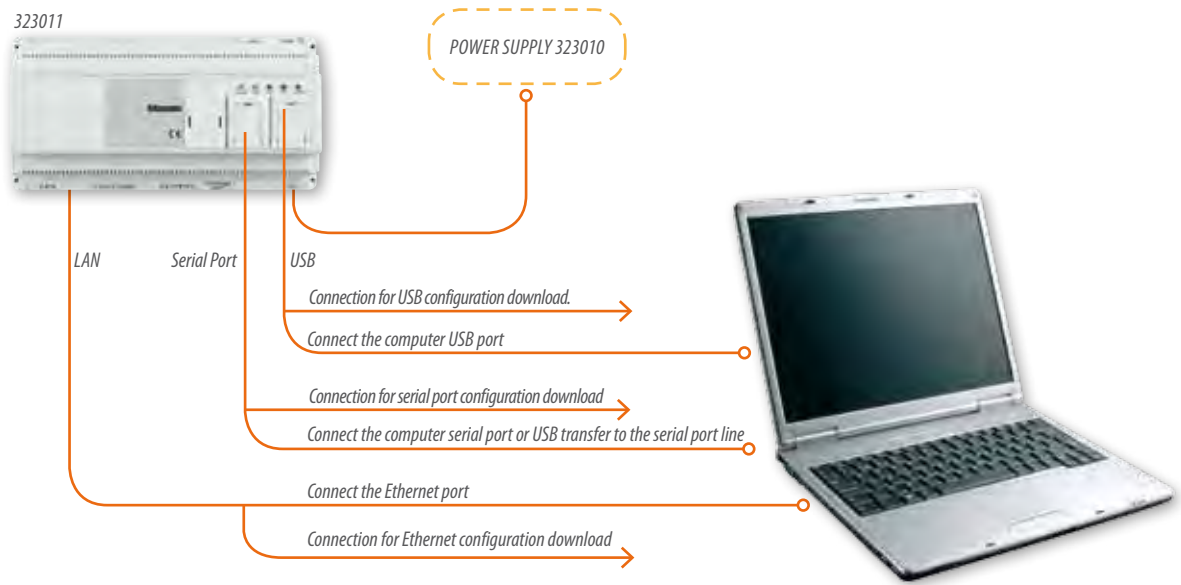




## System accessories functions overview

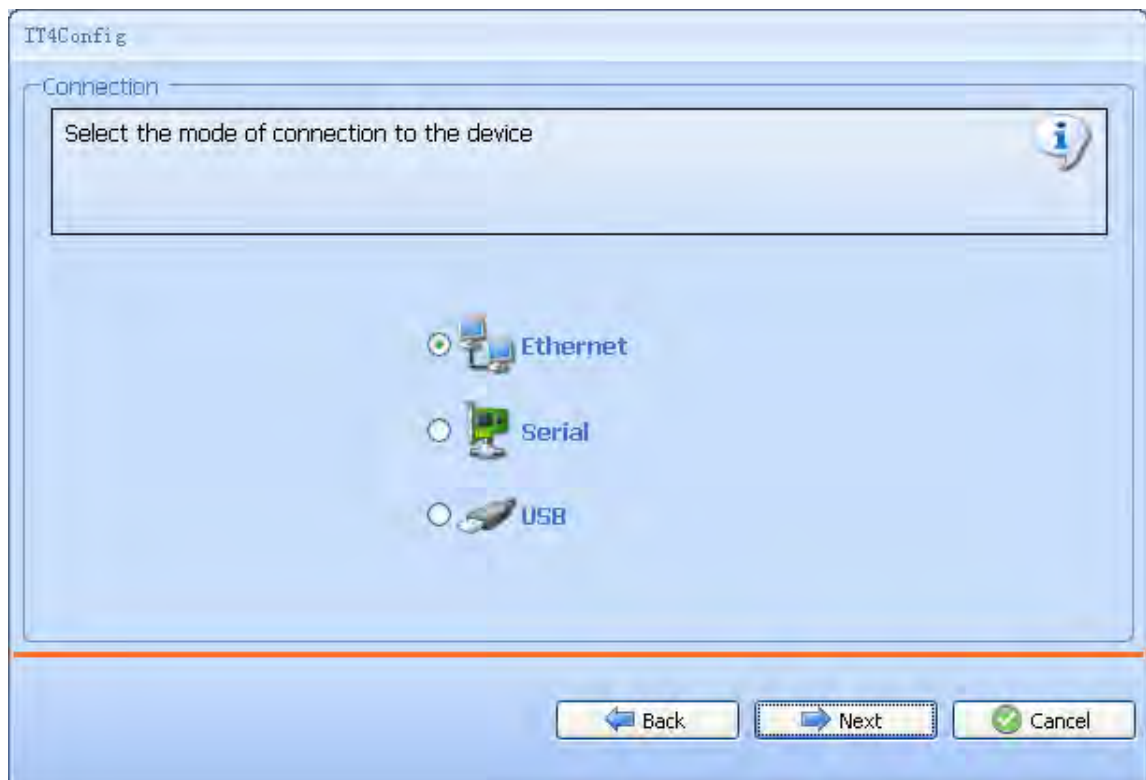
### 323011 - D45/IP INTERFACE


Prepare for the configuration lines

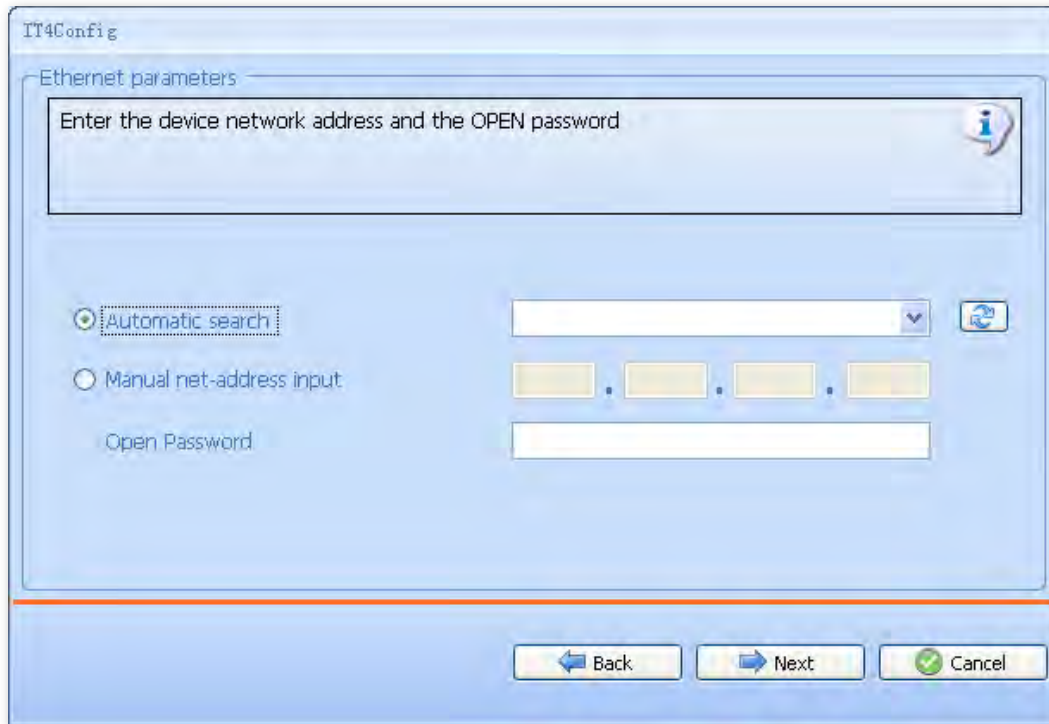
The D45/IP interface has options for downloading the configuration: online download, serial port download, and USB download.



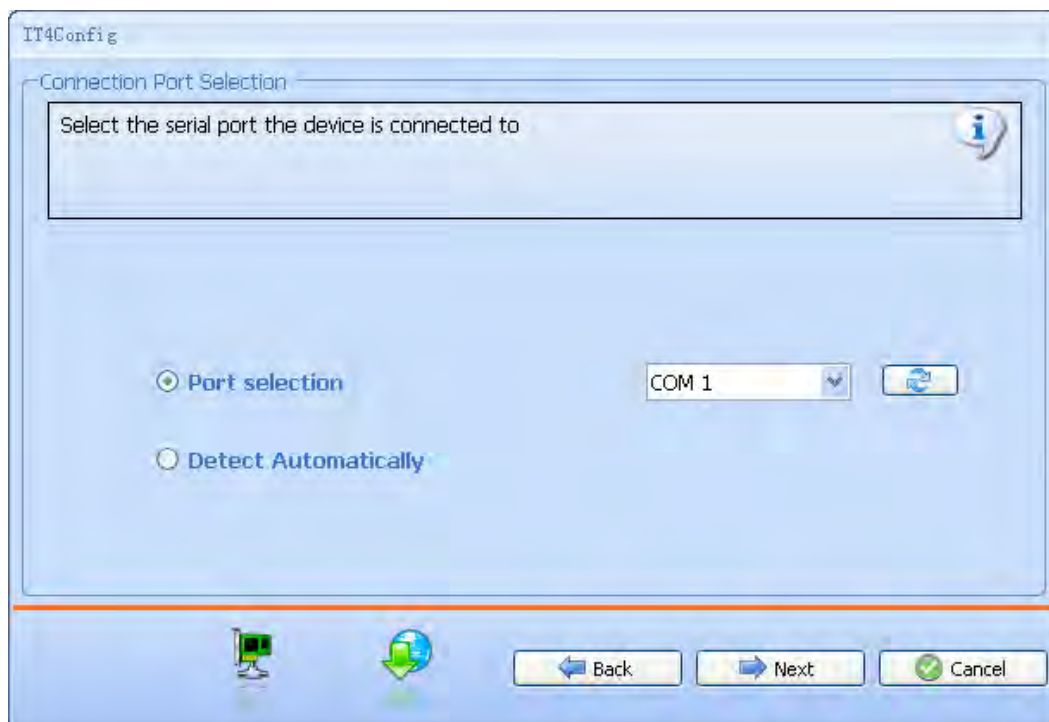
On completing the above configuration, press  to save the configuration for future view or maintenance. Press  used for the download configuration.



As for the above, you can select Ethernet for the configuration. Click NEXT and as shown in the following diagram. The first time "Automatic search" can be used. Click  and let the system find 323011, after which you can input the password into Open Password. The initial password is 12345. Then click NEXT to go to the download configuration interface. (it will indicate either success or failure).




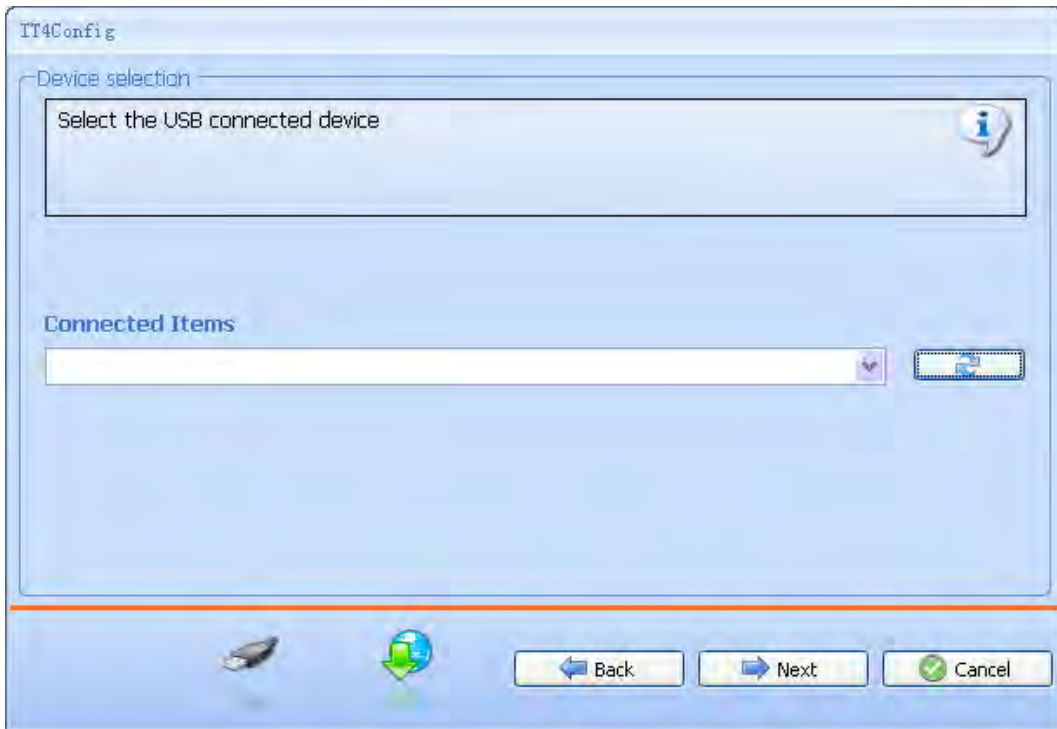
If serial port is selected for the configuration, click NEXT. As it can be seen in the following diagram, select the port selection to manually, specify the serial port number, and select Detect Automatically to automatically detect the serial port. It is not necessary to specify the serial port. Then click NEXT to go to configuration download. (The serial port does not require password). It will indicate either success or failure.



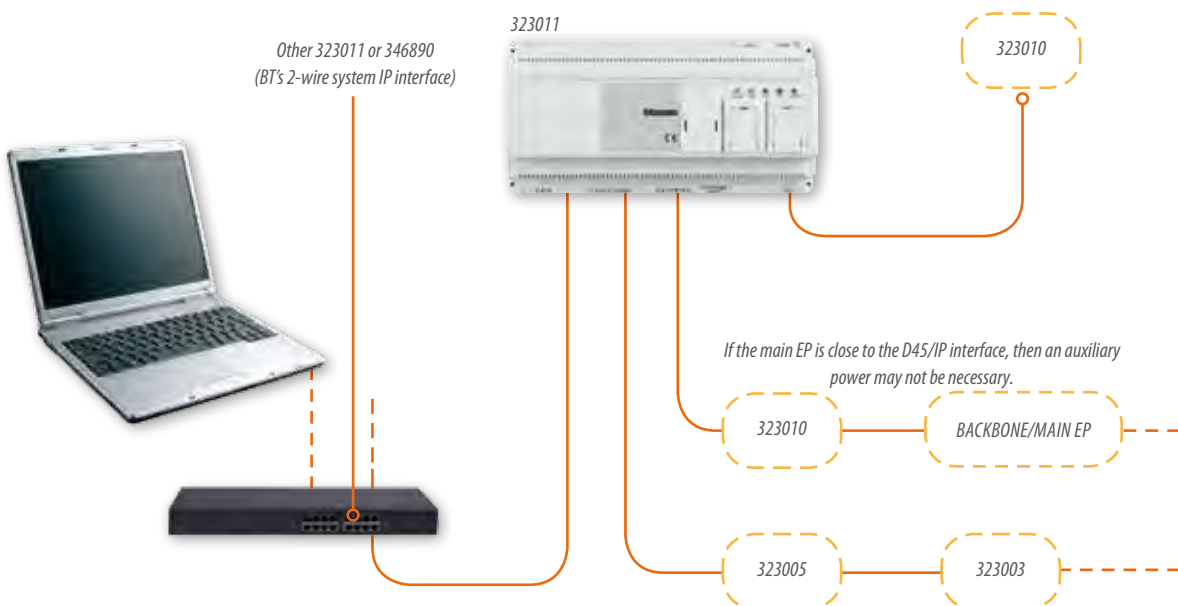
## System accessories functions overview

### 323011 - D45/IP INTERFACE

If you select USB for the configuration, you must first install the USB driver so that the system can identify the USB port. Click NEXT. As it can be seen in the following diagram, if you click  it will automatically find the USB connection. Then click on NEXT to go to configuration download (no password required). It will indicate either success or failure.



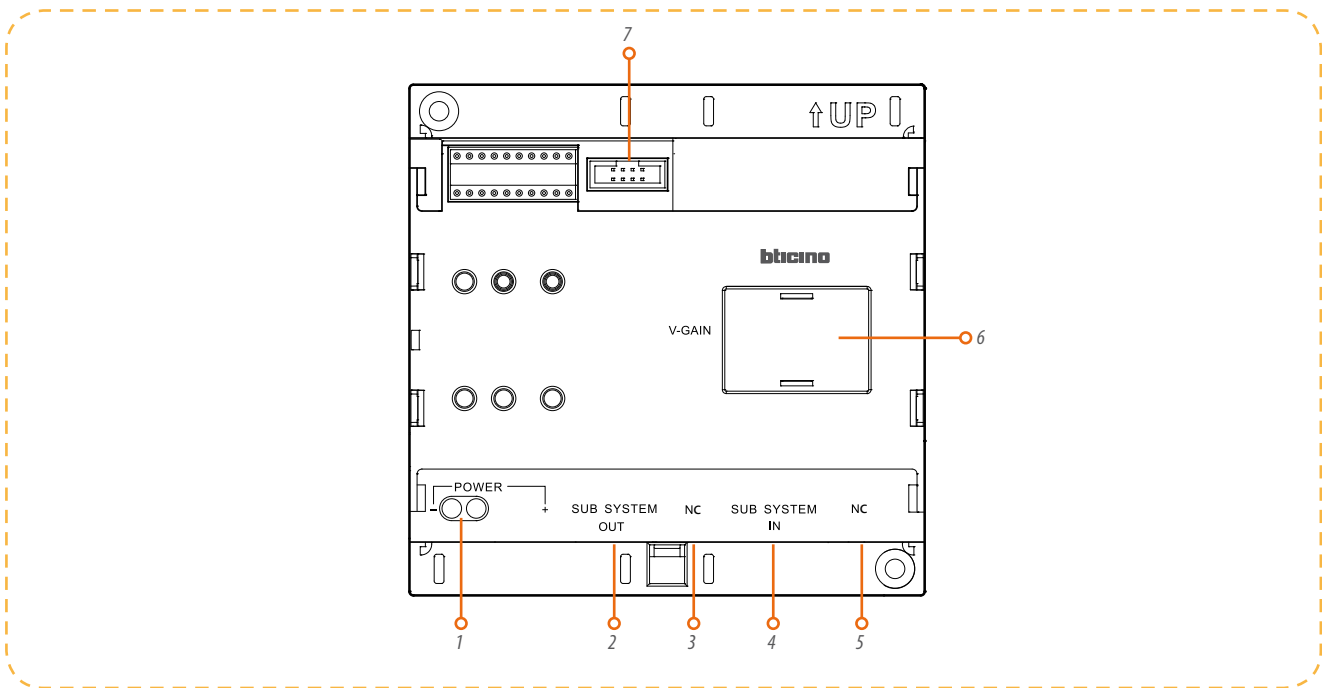
### WIRING OPTIONS FOR THE INSTALLATION OF ITEM 323011



**323019 - SYSTEM EXPANSION INTERFACE**

323019 is used to extend riser system. When the number of handsets of one riser exceed 400, the interface can be used to extend the quantity to 800. It's connected by serial connection to the riser BUS to separate riser system BUS and ensure signal transmission quality by forwarding all the signals and video gain adjustments for better video transmission quality.

System expansion interface



**LEGEND**

1. Power supply input connector 30 Vdc
2. Output connector for riser system: Floor shunt SUB SYSTEM IN interface
3. Empty (not used)
4. Input connector for riser system: Floor shunt SUB SYSTEM OUT interface
5. Empty (not used)
6. Video gain adjust switch
7. Configuration connector for updating software and connect the PC in series

Video gain setting instruction (switch to left is ON, switch to right is OFF) The instruction data in above table may be different during actual operation. To adjust and set data take into account the actual image.

	Distance	1	2	3	4
<b>COLOUR SIGNAL</b>	0 – 300 m	OFF	OFF	OFF	OFF
	300 – 700 m	ON	OFF	OFF	OFF
	700 – 1000 m	ON	ON	OFF	OFF
<b>B/W SIGNAL</b>	1000 – 1500 m	ON	ON	ON	OFF
	1500 – 2000 m	ON	ON	ON	ON

## System accessories functions overview

### 323005 - POWER SUPPLY

### 323010 - AUXILIARY POWER SUPPLY

In D45 system, there are two types of power supply: 323005 and 323010.

323005		323010
can be the system power supply	can be the additional power supply	can only be the additional power supply

Comparison between 323005 and 323010.

FUNCTION	323005		323010
	set to be system PW	set to be additional PW	additional PW
supply power to devices	√	√	√
power supply management	can be on or off	off	×(Not exist)
smart power supply	can be on or off	can be on or off	×(Not exist)
supply power to data communication cable	√	×	×
impedance matching	√	×	×

From above table, the biggest feature of 323005 is that: it's capable of supplying power to the data communication cable, and offer impedance matching for the audio channel at the same time. Therefore, the system power supply is necessary in any D45 system project.

In the project, item 323005 is normally used as system power supply; only when the system needs additional power supply with smart function, item 323005 will be used as additional power supply; otherwise, the additional power supply normally used will be item 323010. For more information, please refer to chapter: rules for using the power supply in the system.

### 323005 FUNCTIONS

Loaded short circuit protection: if the DC output suffers a short circuit, the power supply will enter protection status and stop the voltage output. After the problem is solves, it will come back to normal automatically. Smart power supply: in system where various Small EP are connected with the handset, it may happen that several Small EP will call the handset at the same time. This will leads to heavy load for the power supply. In this case (Power supply cannot supply voltage and all devices cannot work); using a smart power supply will avoid this problem. The smart power supply will allow a maximum quantity of EP to call the handset at the same time on the condition that normal power supply to the system can be assured.

Power supply,  
Auxiliary power supply



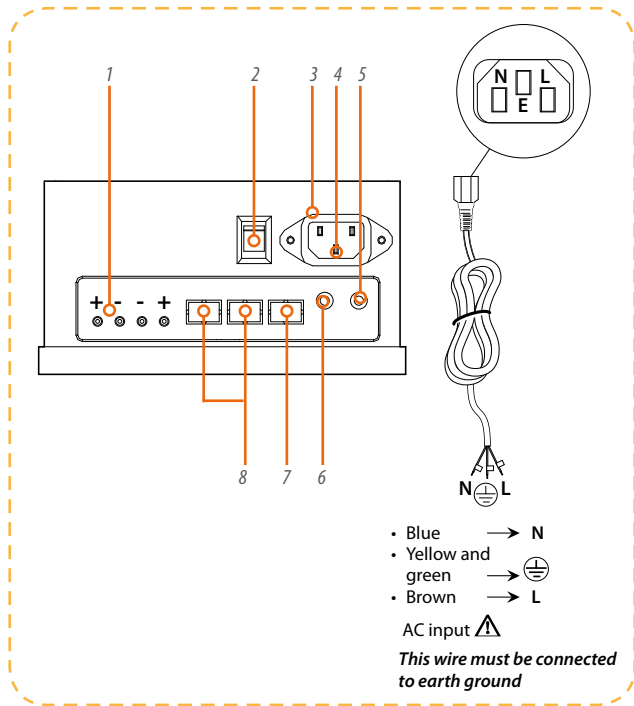
### 323010 FUNCTIONS

Loaded short circuit protection: if the DC output suffers a short circuit, the power supply will enter protection status and stop the voltage output. After the problem is solves, it will come back to normal automatically.

Notes on power supplies:

1. they should be installed in cool places with good air flow. Please do not use anything to block the air vents (on two sides and top of box) of the power supply.
2. Please do not connect the power output port of the power supply to any other power supplies in parallel.

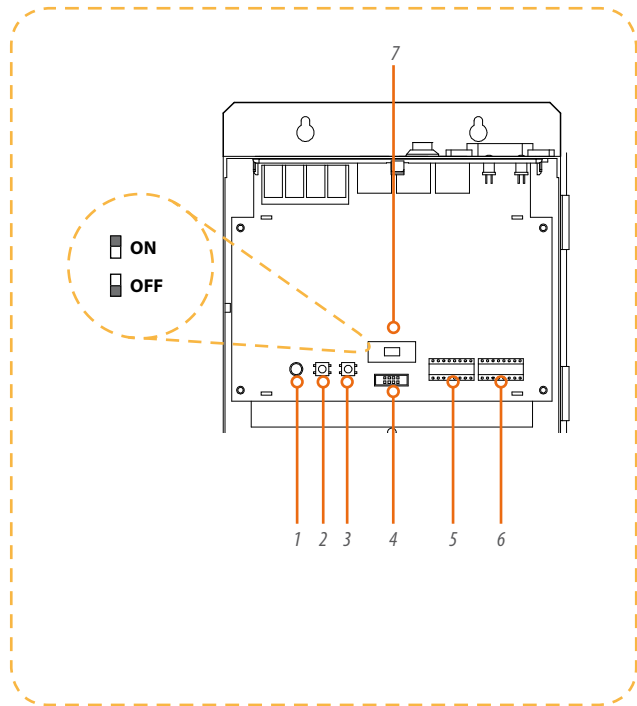
**FUNCTIONS OF POWER SUPPLY CONNECTORS**



**LEGEND**

1. Battery
2. Switch ON/OFF
3. AC IN
4. Protect Earth (must be connected to earth/ground)
5. Power off: red light on; Power on: green light on
6. Low voltage indicator: red light on
7. Data, audio, video transmission
8. Data, audio, video and power transmission

**FUNCTIONS OF CONNECTORS ONLY FOR 323005**



**LEGEND**

1. CFG: configuration light
2. S1: configuration pushbutton
3. S2: configuration pushbutton
4. serial port for upgrading software
5. configuration socket
6. configuration socket
7. Impedance switch:
  - ON connect audio impedance and supply power to communication cable
  - OFF cut audio impedance and stop supply power to communication cable

## System accessories functions overview

### 323005 - POWER SUPPLY

#### 323010 - AUXILIARY POWER SUPPLY

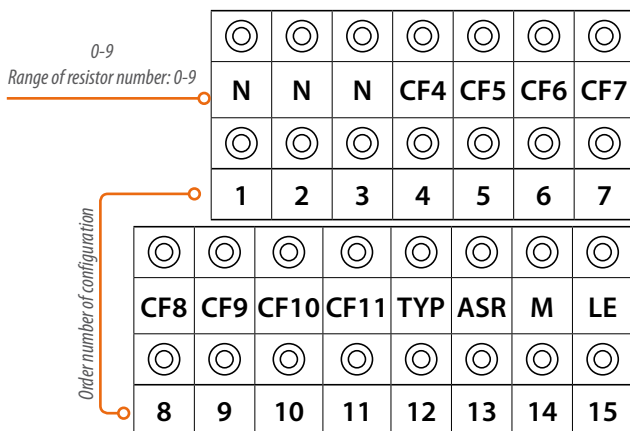
When the impedance switch is ON, 323005 is set as system power supply: it supplies power to the data communication cable and input audio impedance.

When impedance switch is OFF, 323005 is set as additional power supply: it does not supply power to the data communication cable and cuts audio impedance.

323005 The power supply device configuration is to set power supply address, the address range or floor range powered by the device, power supply type (system supply, additional supply), alarm current that power supply offers to each handset, enable or disable smart power supply and PW management, and select system configuration mode. Only if the configuration is correct can the system work correctly. There are 3 configuration methods: resistor configurator, pushbutton setup, and by SF2 software. The resistor configurator has the highest priority. If the resistor configurator method is used on 323005, then the other configuration method will be ineffective.

*Note: if the resistor configurator method is used, this will be validated after pressing and holding down the S1 and S2 pushbuttons at the same time, or after the power supply is restarted.*

1. Configuration using the resistor configurator. There are 3 configuration methods using resistor configurators: mode 1, mode 2, and mode 3. The user can choose one of them according to the complexity of the system. The 14 th bit is used to mark the mode used. For the details please see the system configuration chapter.
2. Pushbutton method ( only effective when the resistor configuration method is not used)



1. Enter configuration status: in standby press input key S2 and hold for 2 s. The CFG light will be always on. Enter the configuration setup status. (If there is a resistor configurator installed or if the pushbutton configuration has been performed incorrectly, the device cannot enter configuration setup status).

2. Enter the configurator number (i.e. select one configurator): press S2 to count. Each pressure will increase the number by one (no press= 1st one) and the CFG light will flash once.
3. Confirm the configurator number: press S1 then CFG light flash quickly twice. Then it will come on steady.
4. Enter the configuration parameter: press S2, the default parameter is 0. Increase by 1 with each pressure. The CFG light will flash quickly twice . The highest number possible is 9.
5. Confirm the configuration parameter: press S1, the CFG light will flash quickly twice and then flash slowly twice. Then the configuration procedure for this step is now completed.
6. Set the next parameters: if necessary, set the other configuration parameters, press S2. The CFG light will flash quickly 3 times. Then proceed according to (2).
7. If the operation is successful, the CFG light will flash slowly once, and the entered configuration parameters will be validated. If the configuration is not successful (for example, one configuration exceeds the acceptable value, e.g. M>1), the CFG light will be off, and the old configuration will be still effective. If the configuration value has logical errors (for example, NNN>256 or #Min IU>#Max IU), the CFG light will keep flashing slowly to indicate the error and pushbutton operation will be disabled. In this case it will be necessary to connect a non-zero (1- 9) configurator to the right position and reconnect the power to clear the pushbutton configuration. Then remove the configurators, reconnect the power and repeat the above configuration steps.

If no pushbutton is pressed for 10 s during the operation, the device will automatically exit configuration mode and the CFG light will go off.

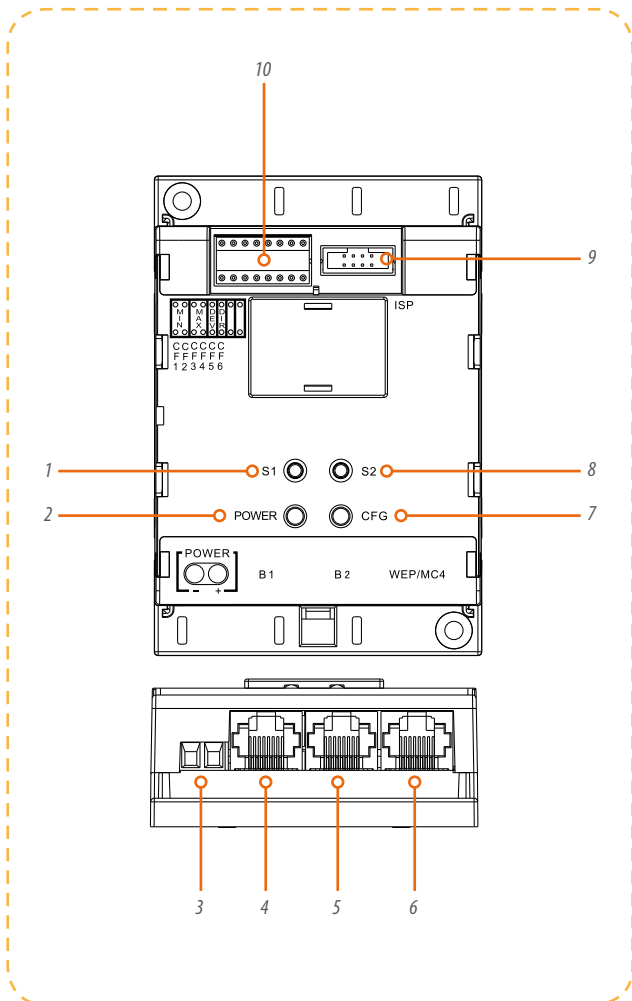
Configuration enquiry:

- Enter configuration enquiry status: in standby press input key S1 and hold for 2 s. The CFG light will come on and the device will switch to configuration enquiry status;
- Enter the configuration number (i.e. select one configurator): press S2 to count. Each pressure will increase the number by one (no press= 1st one) and the CFG light will flash once.
- Confirm the configuration parameter: press S1, the CFG light will flash quickly a number of times. This number of times depends on the parameters being read (for example, if the parameter read is 0, there is no flashing, for one it will flash once, for two it will flash twice). Other operations may be deducted by analogy.
- Exit configuration enquiry status: The CFG light will be off. If no key is pressed for 10 s during the operation the device will automatically switch to standby. The CFG light will be off.

**323018 - EP/SWITCHBOARD SHUNT**

It uses a microprocessor for interface control, and can automatically switch the video channels over. There are 2 configuration methods, by resistor configurator or by pushbutton setting. Once configured it can be used as a Switchboard or main EP backbone expansion interface and can support several wiring methods.

EP/Switchboard shunt



**LEGEND:**

1. S1 key
2. Power supply light indicator
3. Additional power supply connector: DC30V
4. B1 interface: connect the main EP or the Switchboard
5. B2 interface: connect the main network
6. Connect WEP or Switchboard
7. Pushbutton configuration indication
8. S2 key
9. Software update and computer serial configuration interface
10. Configurator socket

## System accessories functions overview

### 323018 - EP/SWITCHBOARD SHUNT

#### Introduction to the configuration procedures

1. Resistor configurator procedure. Insert the resistor configurator of appropriate value into the EP/Switchboard shunt configurator to perform EP/Switchboard shunt configuration. After connection the resistor configurator, press both S1 and S2 for two seconds at the same time and then release so that the EP/Switchboard shunt can be restarted (or repowered) for the new configuration to take effect. Note: The use of the resistor configurator for the configuration will clear the value configured with the pushbuttons.
2. Pushbutton configuration. Set the values of each configuration place using the pushbuttons and configure the EP/Switchboard shunt. You can also read the values of each configuration place using the pushbuttons. Note: When the resistor configurator is connected this method will be invalid.
3. Computer serial port configuration. Use TK1 to connect the PC and EP/Switchboard shunt, and then enter the configuration parameters as per the manual tool configuration operation and download it to EP/Switchboard shunt.

#### Introduction to the configuration place

CF1	CF2	CF3	CF4	CF5	CF6
⊙	⊙	⊙	⊙	⊙	⊙
MC min	MC min	MC max	MC mac	DEV	DIR
⊙	⊙	⊙	⊙	⊙	⊙

#### Meaning of the configuration place

CONFIGURATION PLACE	MODE 1	MODE 2	MODE 3
CF1	Min*	Same as Mode 1	Same as Mode 1
CF2			
CF3	Max**		
CF4			
CF5	DEV		
CF6	DIR		

#### Nota

\*Min: The minimum number connected to the Backbone/main EP or the Switchboard at main EP/Switchboard interface.

\*\*Max: The maximum number connected to the Backbone/main EP or the Switchboard at main EP/Switchboard interface.

#### DEV: Options of main EP/Switchboard types

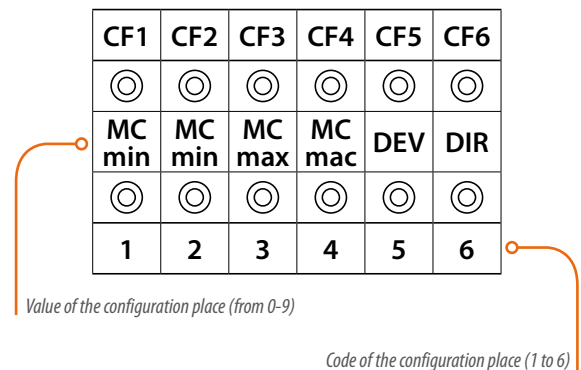
DEV	
0	Switchboard
1	Backbone/main EP

#### DIR: Options of main EP/Switchboard wiring directions

DIR	
0	The Switchboard is connected to the B1 interface and backbone/main EP to the B2 interface
1	The backbone/main EP is connected to B1 and the Switchboard to B2

The DIR configuration for the device wiring direction must satisfy the following rules or irregular system operation will occur:

1. The riser shunt must be connected to B1 of all interfaces in the relevant zone.
2. The wiring direction of the Switchboard and the main EP can be set through the DIR configuration place, but all the interface wiring directions must be identically configured in the project.
3. Pushbutton-configuration operation (it will not be valid if the resistor is inserted in the configurator).



Each pushbutton-configuration place must be relevant to the place at the configurator. For example, if the pushbutton configuration place is coded at 5, then it's relevant to DEV (CF5) in the configurator. Configuration methods by pushbuttons

- Enter the configuration status: In standby, press the S2 key and hold for 2 seconds. The CFG indicator will flash for two seconds and switch to configuration status (If the configurator fitted with a resistor or pushbutton configuration has been performed incorrectly, the unit cannot enter configuration status).
- Enter the configuration place code (to select a certain place at the configurator): press the S2 key to reach the desired number. At every pressure the code will be increased by one 1 (no pressure will give 1) and the CFG indicator will flash once.
- Confirm the configuration place code: Press the S1 key and the CFG indicator will flash quickly twice. Then it emit an extended flash to and enter value configuration mode.
- Enter the configuration place value: Press the S2 key (defaulted at 0). Press once and the value will be increased by 1, the CFG indicator flashing quickly twice.
- Confirm the configuration place value: Press the S1 key and the CFG indicator will flash quickly twice; When it flashes slowly twice, the value is set.
- Set the next place: If you need to set the value of other configuration places, press S2 and the CFG indicator will flash quickly twice. Then continue from point (2).
- End the configuration: Press the S1 key to exit configuration mode. If the procedure has been successful the CFG will flash once and then come on steady. The new configuration is now available. If the procedure fails (one configuration place is over the effective value, like  $DEV > 1$ ), the CFG indicator will be off and the old configuration will be kept. If the configuration value is logically wrong (such as  $Min > Max$ ), then on reset the CFG indicator will flash slowly, indicating wrong configuration and pushbutton operation will stop.

In this case connect the non-zero (1 to 9) resistor to the configurator and repower to clear all the values configured using the pushbuttons. Remove the resistor, repower and reset following the above steps. If during the operation no pushbutton is pressed for 10 seconds, the unit will automatically exit the configuration status and the CFG indicator will go off.

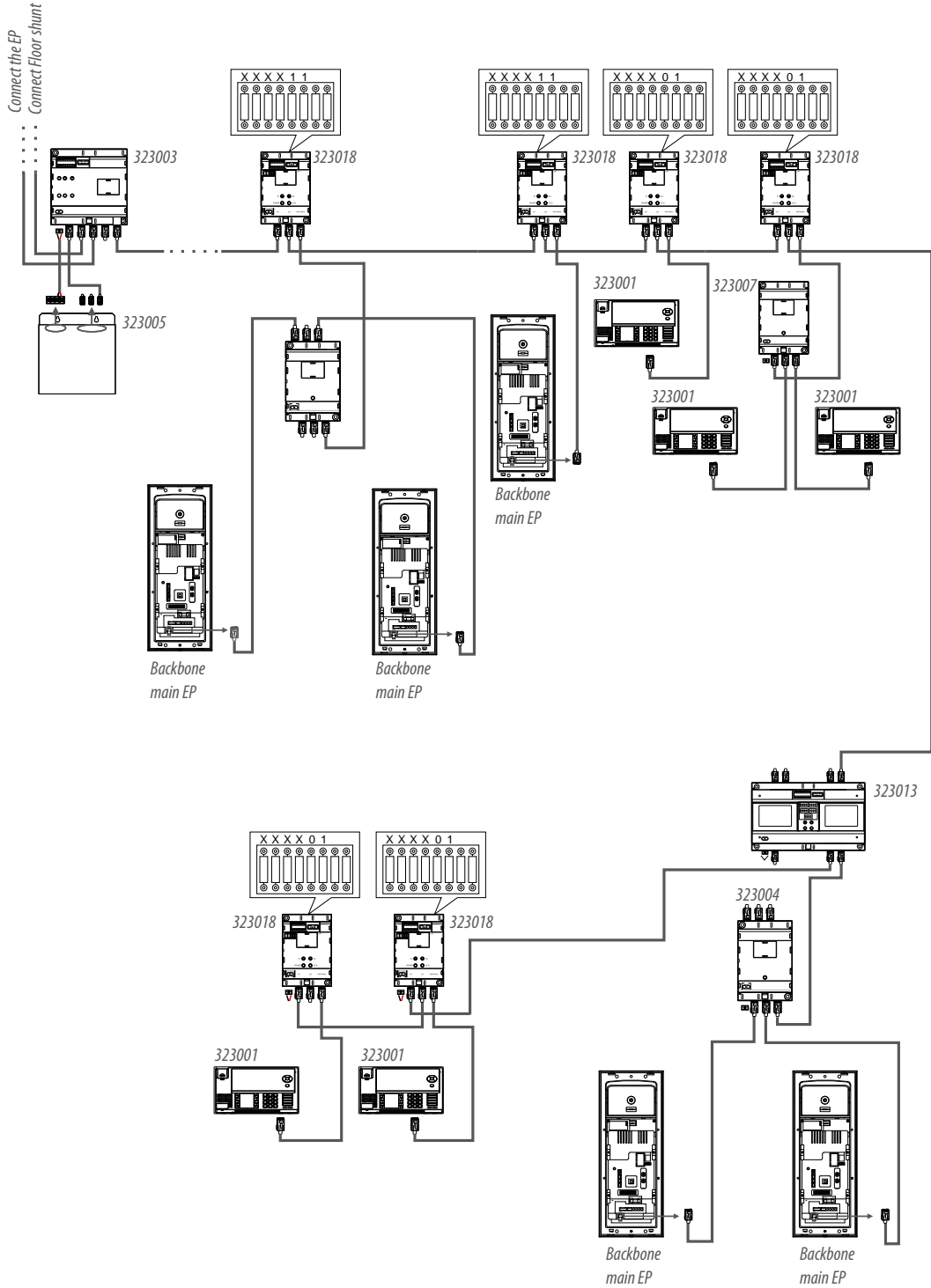
#### *Configuration enquiry methods*

- Enter enquiry status: In standby, press the S1 key for 2 seconds and the CFG indicator will flash slowly and enter configuration enquiry mode (This status is not accessible in case of wrong configuration).
- Enter the configuration code (to select a certain place at the configurator): press the S2 key to increase the numbers. At every pressure the code will be increased by one 1 (no pressure will give 1) and the CFG indicator will flash slowly twice.
- Read the configuration value: Press the S1 key and the CFG indicator will flash. The number of times it will flash will depend on the size of the value (For example, if the reading result is 0, it won't flash; if it's 1, it will flash once, and if 2, it will flash twice, and so on), and then move to the next step.
- With the CFG indicator off, it will exit configuration enquiry status: If during the operation no pushbutton is pressed for 10 seconds, the unit will automatically exit the status.

# System accessories functions overview

## 323018 - EP/SWITCHBOARD SHUNT

### EXAMPLE: TYPICAL WIRING OF EP/SWITCHBOARD SHUNT



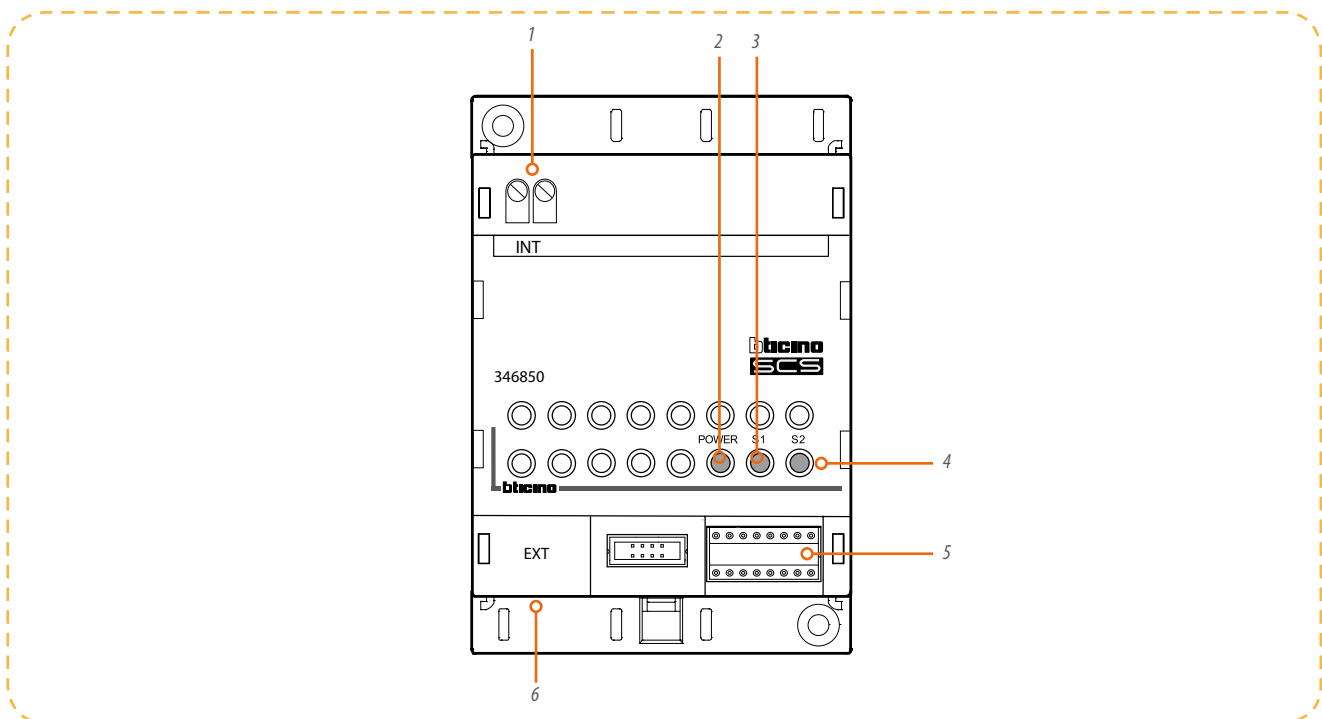
**346858 - D45 TO 2 WIRE INTERFACE**

D45/BTicino 2-wire interface (346858) is a switch-over interface device made by BTicino that can be used for installing the BTicino 2 wire system or BTicino 2 wire intelligent home devices in the D45 system.

D45 to 2 wire interface



**FUNCTIONS OF CONNECTORS**



**LEGEND**

- 1. INT: 346858 external communication port. It's a 2-wire interface to connect the HANDSET or the BTicino home system.
- 2. POWER: Power indication; when the red indicator is on, it means a normal power supply.
- 3. S1 internal-status indicator; when it's on, it means that the internal end of 346858 is engaged
- 4. S2 external-status indicator; when it's on, it means that the external end of 346858 is engaged
- 5. Resistor configurator: used to configure the setting parameters.

- 6. EXT: 346858 external communication port. It's RJ45 interface to connect the HANDSET interface or the floor shunt to the D45 system.

Remarks. With communication, both internal and external, two LEDs (S1 and S2) will flash.

## System accessories functions overview

### 346858 - D45 TO 2 WIRE INTERFACE

346858 can be configured in two ways: 1) simple configuration (Mode 1); 2) flexible configuration (Mode 2)

	CF2		CF4		CF6		CF8
⊙	⊙	⊙	⊙	⊙	⊙	⊙	⊙
F		I		#I		MC	
⊙	⊙	⊙	⊙	⊙	⊙	⊙	⊙
CF1		CF3		CF5		CF7	

Remarks. FFII= the number of the handset (FF refers to the first two places of the IP number and II refers to the last two places, namely the room number at the floor).

CONFIGURATION PLACE	SIMPLE CONFIGURATION MODE 1	FLEXIBLE CONFIGURATION MODE 2
CF1	FF= the floor number relevant to the HANDSET (01≤FF≤20)	FF= the floor number relevant to the IP (01≤FF≤99)
CF2		
CF3	II=the room number relevant to the IP floor (01≤II≤04)	II=the room number relevant to the IP floor (01≤II≤#II)
CF4		
CF5	#II (Mode 1, default 04, no need to set)	#II=household number of the unit (01≤#II≤99)
CF6		
CF7	MC (no need to set, relying on the setting of the Riser shunt)	MC (no need to set, relying on the setting of the Riser shunt)

Note: MC refers to the address of the Switchboard, with no need to set on 346858, relying on the C-place setting on the Riser shunt.

### EXAMPLE

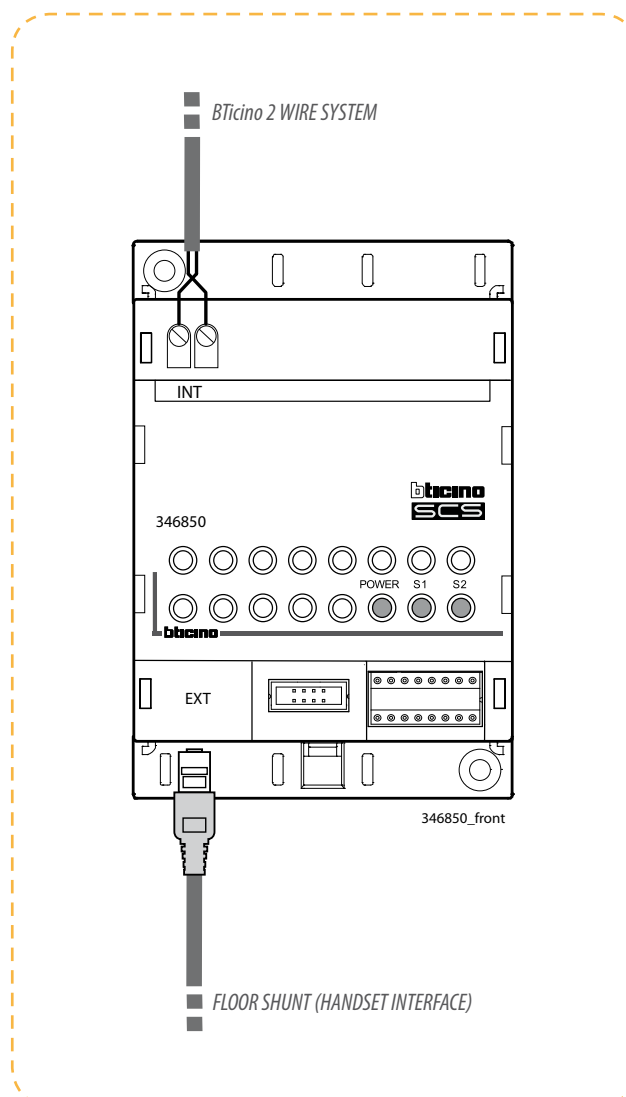
1. If the unit building relevant to 346858 has 18 floors, 4 households on each floor, then D45 system can use Mode 1 for the system configuration. If the 346858 floor is 17/F and the second household, then its configuration can be as follows:

CONFIGURATION PLACE	SIMPLE CONFIGURATION MODE 1
CF1	
CF2	FF=17
CF3	
CF4	II=02
CF5	
CF6	Default 04, no need to set
CF7	No need to set, relying on the setting of the Riser shunt

2. If the unit building relevant to 346858 has 28 floors, 3 households on each floor, then D45 system can use Mode 2 for the system configuration. And the 346858 floor is 10/F and the second household, then its configuration can be as follows:

CONFIGURATION PLACE	SIMPLE CONFIGURATION MODE 2
CF1	
CF2	FF=10
CF3	
CF4	II=01
CF5	
CF6	#II=03
CF7	No need to set, relying on the setting of the Riser shunt

### Wiring method for 346858



Remarks: 346858 will automatically get its power from BT's 2-wire connection end of INT.

**323020 - CONFIGURATION TOOL**

This package consists of the Tool interface and the Configuration tool, used by technicians to download the configuration information or update programs for the target devices (EP and interface, etc.) of the D45 system.

**PACKING LIST**

- Tool interface 1 piece
- Configuration tool disc and disc box 1 piece
- 9P serial extension line 1 piece
- 8P flat cable 1 piece

*Directions for the Configuration tool*

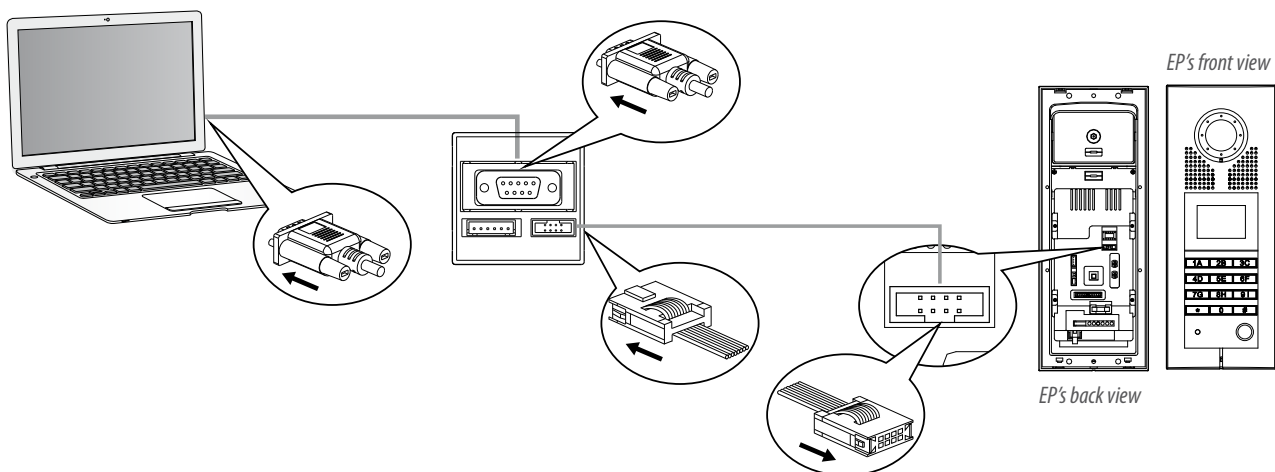
For the details of how to use the 323020 disc software, please refer to the instructions on the box, the help document, or the relevant sections in this manual.

*Wiring method for the tool interface*

Wiring method 1 (insert as per the arrow direction):

This method is mainly used to download the configuration information (such as to download the configuration information for backbone/main EP, Riser shunt, Switchboard, Power supply), and to update the programs for some devices.

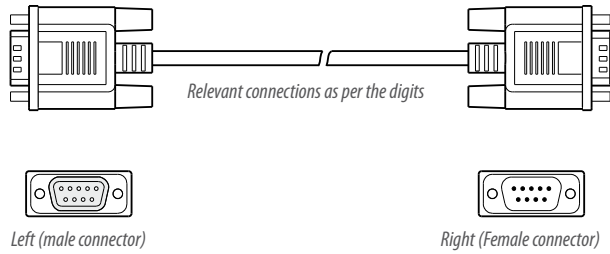
Tool interface



*Note: 9P serial-port extension line: please use the line in agreement with the following information.*

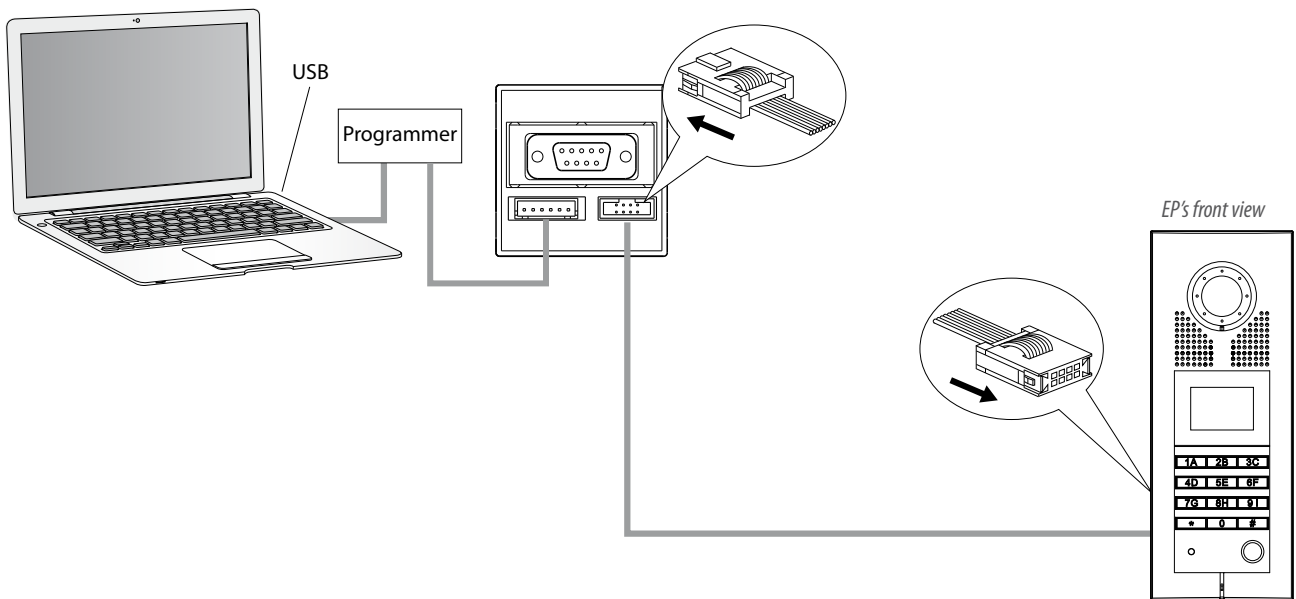
# System accessories functions overview

## 323020 - CONFIGURATION TOOL



LEFT	RELEVANT CONNECTION AS PER THE DIGITS	RIGHT
1	↔	1
2	↔	2RX
3	↔	3TX
4	↔	4
5	↔	5GND
6	↔	6
7	↔	7
8	↔	8
9	↔	9

Wiring method 2: **Only for firmware specialist to upgrade.** It's only used to update the programs (Most devices are updated in this way).



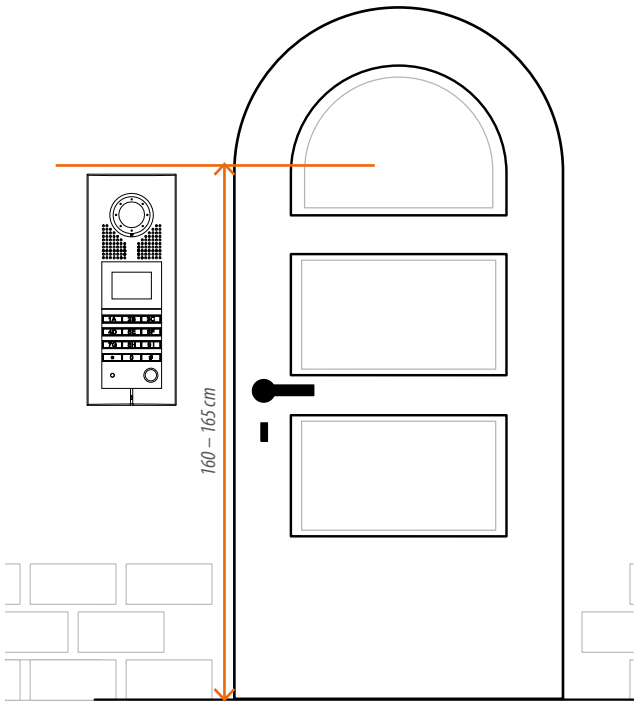
**INDEX****INSTALLATION RULES**

Entrance panels and indoor handsets installation .	74
System cable . . . . .	77
Standard RJ45 connections. . . . .	78
Lock type and distance limits . . . . .	81
Power supply installation rules . . . . .	83
Power supply check and calculation . . . . .	89
Maximum system limits . . . . .	93

## Entrance panels and indoor handsets installation

### SMALL EP/EP/MAIN EP INSTALLATION HEIGHT

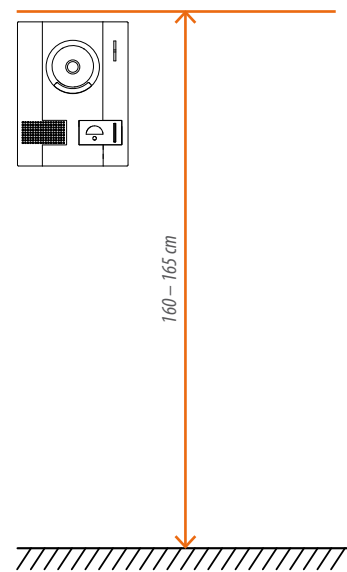
Below is the recommended installation height for the entrance panel:



*Note: To allow use by disabled people, the device must be installed at a height of 120-125 cm.*

### HANDSET INSTALLATION HEIGHT

When installing audio or video internal units, it is advisable to position the devices as indicated here.



*Note: To allow use by disabled people, the device must be installed at a height of 120-125 cm.*

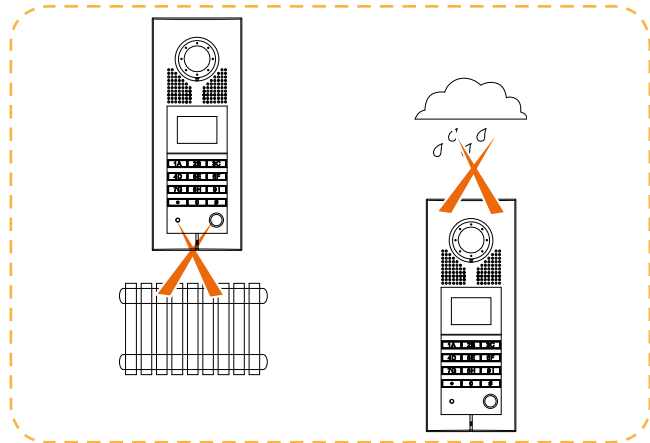
### RECOMMENDATION FOR THE INSTALLATION

#### POSITION OF THE SMALL EP/EP/MAIN EP

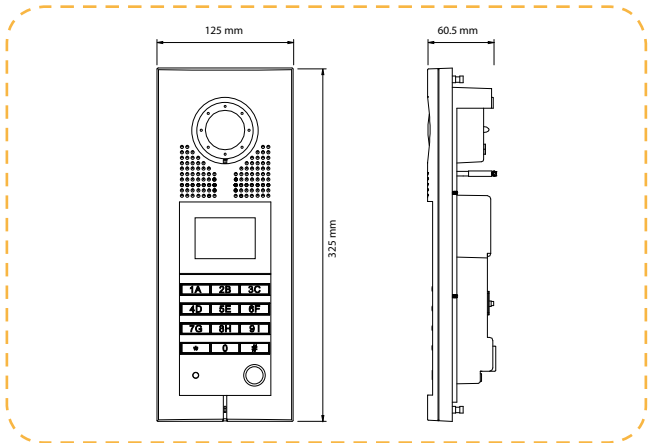
The most important condition to observe in the positioning of cameras is that they must not be turned towards light source (for example, lamps, sunlight, reflecting surfaces, etc.).

# Entrance panel installation

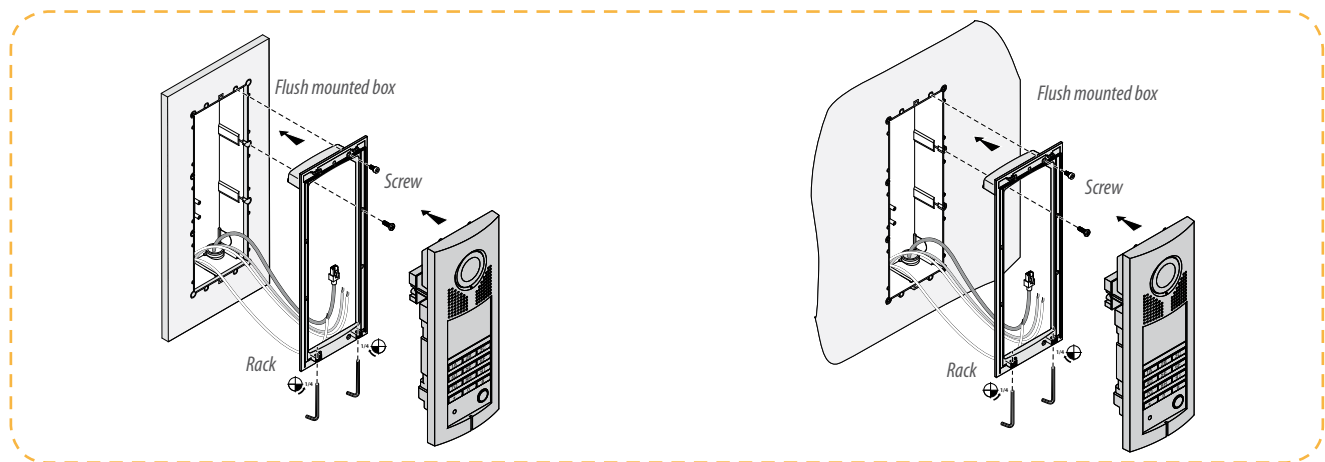
## 322010 INSTALLATION METHOD



*Don't install in hot or damp places*



*Size overview*



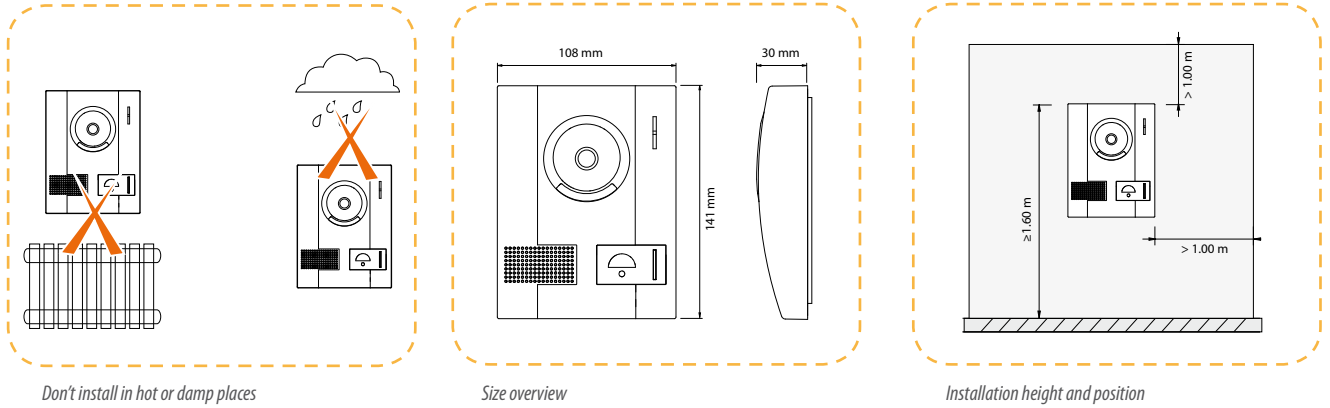
*Install the EP on the door*

*Install the EP on the wall*

*Note: The flush mounted box must be ordered separately.*

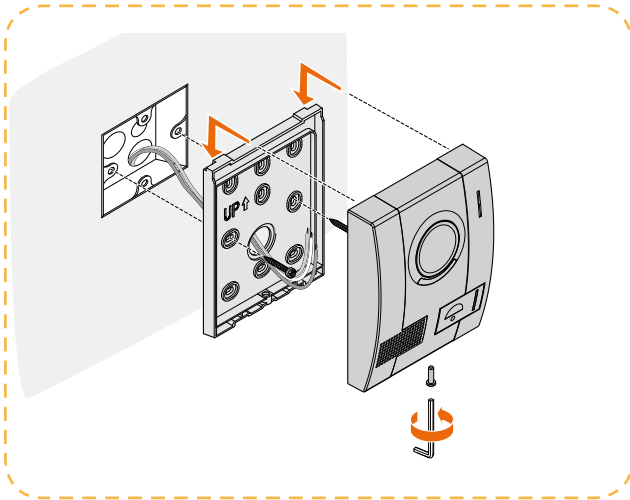
## Small entrance panel installation

### 322020 INSTALLATION METHOD



### DO NOT INSTALL IN HOT OR DAMP PLACES

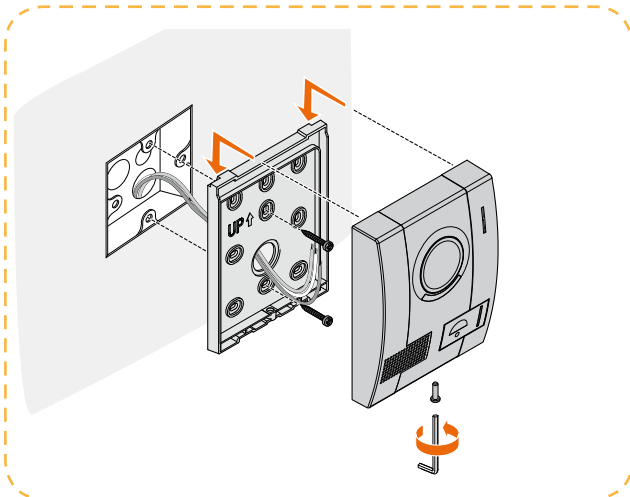
#### Installation method 1



#### Installation instruction:

1. Fix the base to the flush mounted box using the horizontal holes;
2. Connect the cable to EP clamps and fit the cover to the body using the two grooves on the top;
3. Secure the cover in position.
4. Tighten up the bottom screw.

#### Installation method 2

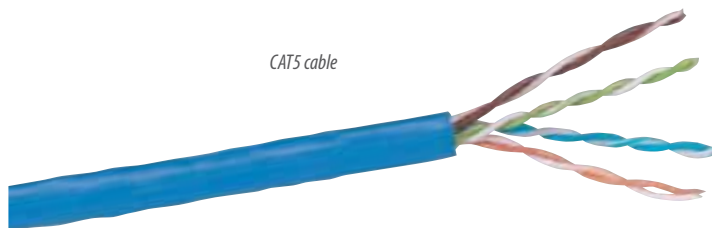


#### Installation instructions:

1. Fix the base to the flush mounted box using the vertical holes;
2. Connect the cable to EP clamps and fit the cover to the body using the two grooves on the top;
3. Secure the cover in position.
4. Tighten up the bottom screw.

## System cable

The D45 system only works correctly if CAT5 original cables are used. Twisted pairs offer good standard and differential immunity. The CAT5 cable must have a resistance value of 180 ohm/km ( for every twisted pair).



TIA/EIA CATEGORY	ISO/IEC CLASS	ANSI/TIA/EIA STANDARD	ISO/IEC STANDARD	FREQUENCY MHZ	COMMON IEEE OR TIA/EIA APPLICATIONS
CAT5	D	568-A	11801:1999	100	802.5 - Token Ring 802.3 - 10BASE-T Ethernet 802.3 - 100BASE-T Ethernet
CAT5e	D	568-B	11801:2002	100	802.5 - Token Ring 802.3 - 10BASE-T Ethernet 802.3 - 100BASE-T Ethernet 802.3 - 1000BASE-T Ethernet

BTicino recommend the use of its cable CAT 5.

Details as follows:

CAT.5E U/UTP CABLES			
U/UTP	SHEATH	LENGTH	PACKAGING
032750	LSZH	305 m	BOX
032751	PVC	305 m	BOX
032873	LSZH	1000 m	COIL
032874	PVC	1000 m	COIL

Unshielded U/UTP cat. 5e cables with solid copper 24AWG (0.51 mm) conductors, polyolefin insulation, 4 twisted pair with internal separator – in accordance with ISO/IEC 11801 e 2.0, EN 50173-1 e EIA/TIA 568 B2. 10 standard – colour grey.

## Standard RJ45 connections for CAT5 cable

Two standards (T568A and T568B) of wires connection, both suitable, although it is recommended that they are not mixed in the same installation. Table 1 shows the two standards.

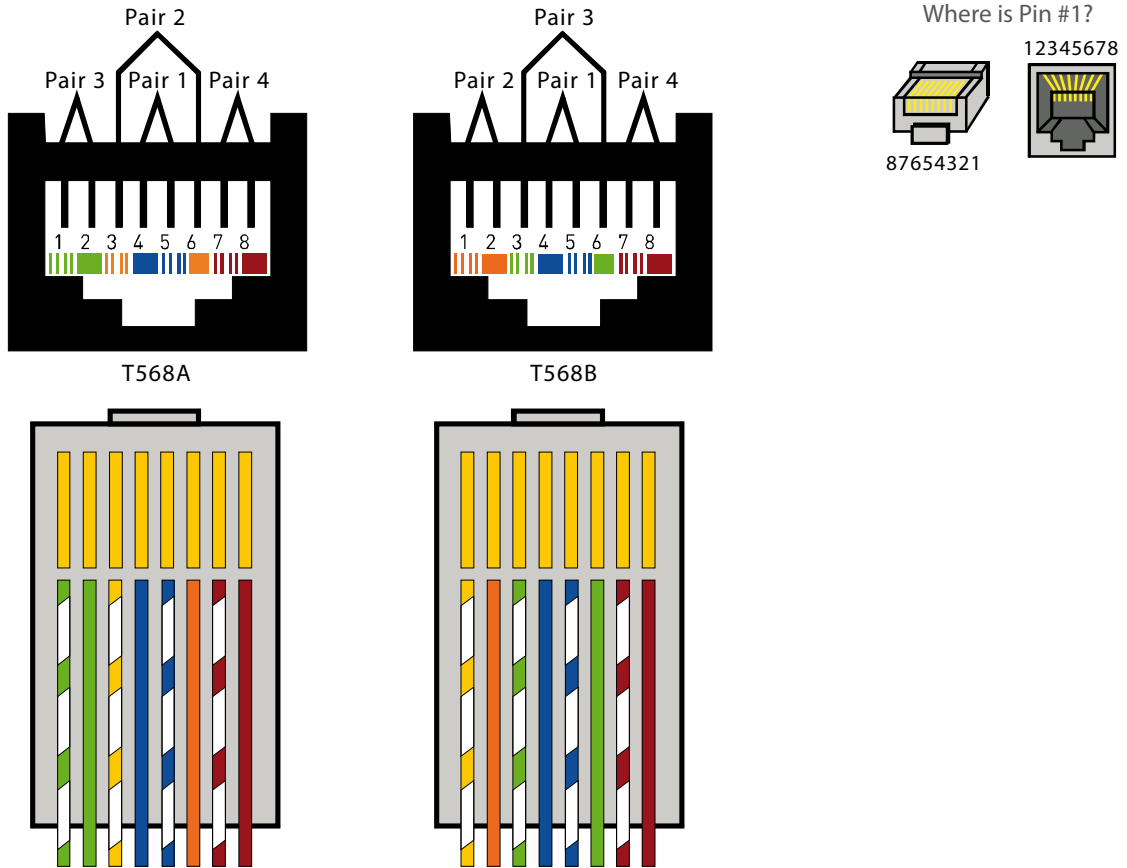



Table 1

PIN n°	T568A		T568B		SIGNAL
	pair	wire colour	pair	wire colour	
1	3		2		VIDEO +
2	3		2		VIDEO -
3	2		3		AUDIO +
4	1		1		POWER +
5	1		1		POWER -
6	2		3		AUDIO -
7	4		4		SCS-
8	4		4		SCS+

The four pairs are identified with different colours and each pair carries a different type of signal (see Table 1).

# RJ45 connections

## RJ45 WIRE MAP AND CONNECTION METHOD

WIRE MAP	1	2	3	4	5	6	7	8	1~8
Colour	White&orange	Orange	White&green	Blue	White&blue	Green	White&brown	Brown	
SIGNAL	Video+	Video-	Audio+	Power+	Power-	Audio-	Data-	Data+	

Wire specification: CAT cable

1. Tools for making and testing CAT5 connections.
2. Steps for making and testing CAT5 connections.



Wire crimping tool



Tester



**Step 1:** Use the crimping tool to cut the desired length of Cat 5 cable.



**Step 2:** Remove the outer grey cable sheath. Use the crimping tool to cut the wire tips. Place the stripper on the cable, hold, twist and pull toward the cable end to strip the cable sheath off. .

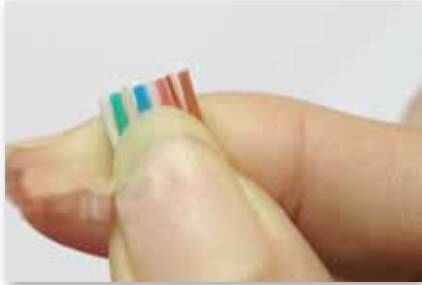


**Step 3:** Separate the exposed coloured strands. Smooth out the strands and untwist each pair. Straighten out each wire and put them in order of colour. Make sure the cable is free of crimps and is straightened.



**Step 4:** after Straightening out each wire and putting them in colour order, check the order again. Use the tip of the crimping tool to cut the wire tips. You want to cut on a sharp slant. Otherwise, the difference in wire length will affect the contact with the RJ45 connector. If too much sheath is removed, just cut the bare wire lengths down as required. The bare wire length should be 1.5 mm. This length will make it easier to fit them to the RJ-45 connector.

## RJ45 connections



**Step 5:** Hold the RJ-45 connector between your fingers with the copper connectors face up. Slide the wires into the connector, ensuring that each coloured wire goes into its matching slot. Push the connector firmly against the wires.



**Step 6:** Before lock the wires inside the connector, check from the top of the connector to see that each wire is tightly connected to the copper connector.



**Step 7:** after the final check, Place the attached RJ-45 connector into the wire crimping tool. Squeeze the crimper handles down to lock the wires in place inside the connector. When squeezing, a "click" sound should be heard.

The following picture shows a correctly fitted connector.



**Step 8:** test the cable.

Connect the two RJ45 connectors to the tester. Turn on the test. The two groups of lights will be flashing. If the 8 lights turn to green one by one, it means the cable is correctly assembled. Any red lights or yellow lights indicate an open circuit or bad connection.

Two wire cables must be used in the following conditions:

1. System power supply connection to floor shunt (323002)
2. Addition power supply connection to Floor shunt
3. P18V connection to IT1 P18V
4. EP/ Backbone/main EP connection to door lock, EP/ Backbone/main EP connection to door lock and door lock connection to power supply

Type DC-loop: 2x1.0 mm<sup>2</sup>

Resistance: 39.4Ω/1km

## Lock type and distance limits

### RECOMMENDED RJ45 CONNECTOR

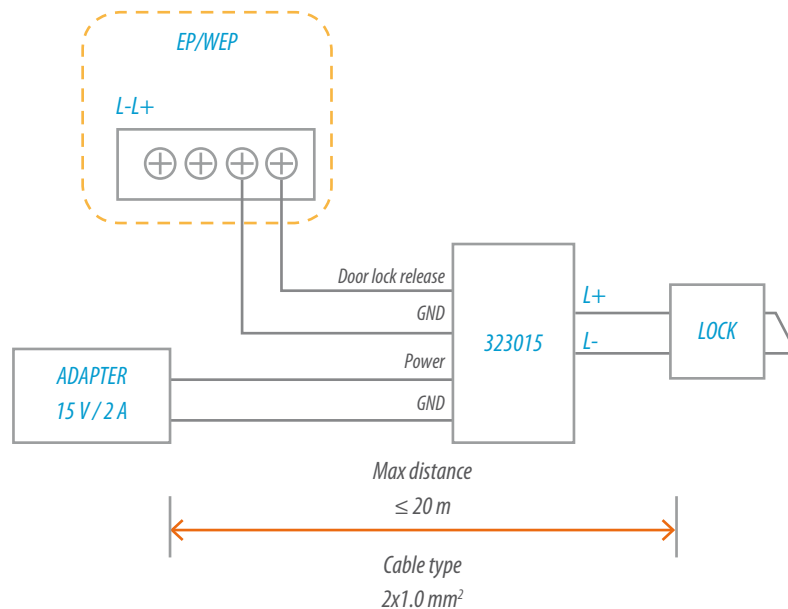
The actual working environment may be damp or hot, which can cause inferior RJ45 connectors to rust. We recommend that Legrand/Ortronics connectors are used (see specific catalogue).

The types of door locks below are also recommended (Shows diagram as figure 1).

No need of power for door lock during stand-b, Door lock releaseVoltage: DC12 V, Door lock releaseCurrent:  $\leq 1$  A, Time needed to release the lock (output voltage to release the lock) :  $\leq 100$  ms



If the current required for the door lock is more than 1A (DC12V), the use of an additional power supply is required instead of obtaining power from the EP. The connection is shown below:



The door lock receives power from an additional power supply, without absorbing any current from the EP.

In some cases, other types of door locks may be used for EPs or main EP. The main characteristic recommended for door locks are below. Need power for lock in stand-by

Stand-by Voltage: DC12

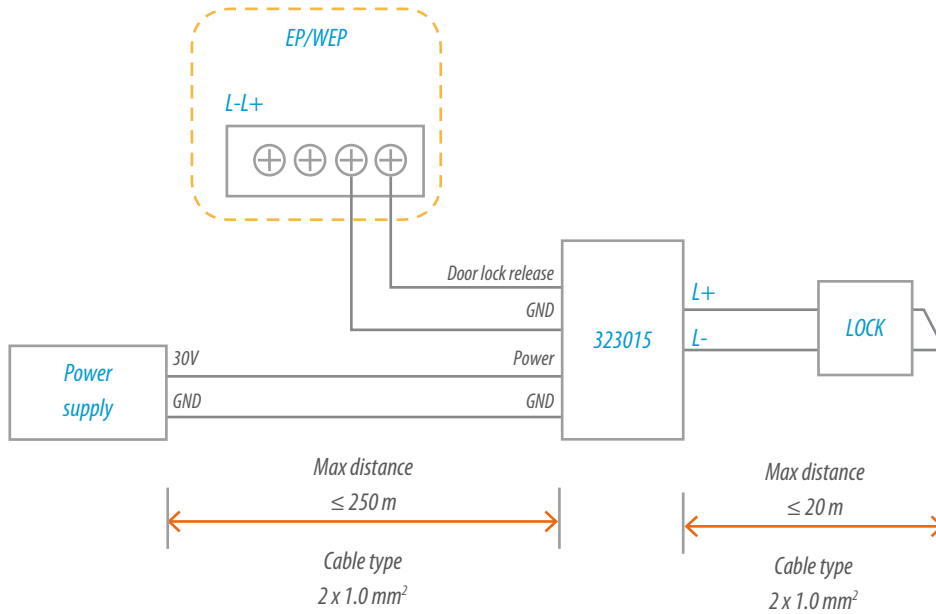
Maximum stand-by Current:  $\leq 0.3$  A

Door lock release method: Stop powering the door lock

Time needed to release the lock: Adjustable

## Lock type and distance limits

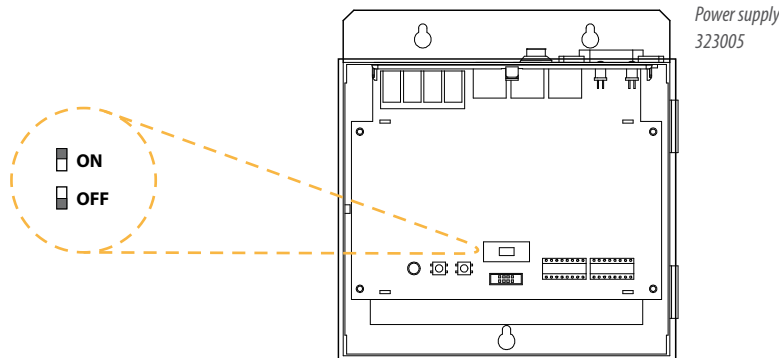
For this kind of door lock, an additional power supply must be used. The connection method is shown below.



The Power supply in the above drawing is the system riser power supply. It can be shared by the riser shunt without the need for an auxiliary Power supply. The power supply is the auxiliary EP power supply (in some cases the riser has several EP. In this case auxiliary power supply will be needed; additional power supply is also needed if the main EP cable is too long). The door lock accessory can be directly connected to this power supply without the need for an additional one.

## Power supply installation rules

There are two kinds of power supplies for D45 systems, the system and the auxiliary power supply.



323005		323010
Can be system PWS when impedance switch is ON	Can be auxiliary PWS (when impedance switch is OFF)	Auxiliary PWS only

### Comparison between Power supply and Auxiliary Power supply

FUNCTION	323005		323010
	SET TO BE SYSTEM PWS	SET TO BE AUXILIARY PWS	AUXILIARY PWS
Supply power to devices	√	√	√
Power supply management	√ (can be on or off)	× (off)	× n/a
Smart power supply	√ (can be on or off)	√ (can be on or off)	× n/a
Supply power to data communication cable	√	×	×
Impedance matching	√	×	×

From above table, it is found that the biggest feature of item 323005 is that: it's capable of supplying power to the data communication cable, and offer impedance matching for the audio channel at the same time. Therefore, In the project, usually PWS smart power supply is used as system power; only when the system needs auxiliary power supply with smart function, the PWS will be set as auxiliary power supply; otherwise, the auxiliary power supply will be used.

### Riser shunt:

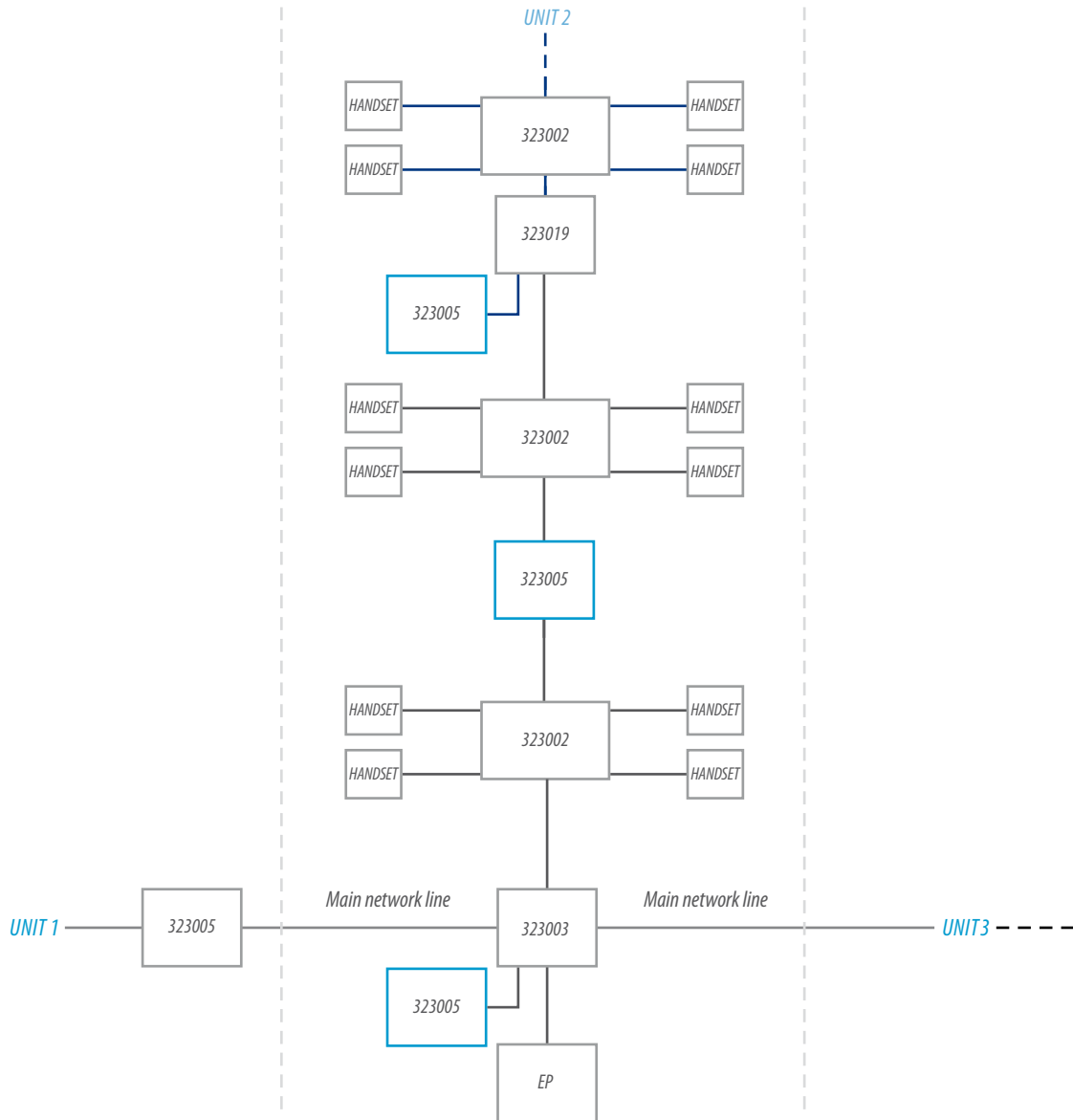
Where system power supply is needed: in D45 systems it is possible to use only 323003, 323019 (able to extend quantity of handsets inside riser) and 323009 (able to connect 5 handsets) to separate audio cable and data communication cable. In order to supply power to each data communication cable segment and matching audio impedance, it is necessary to install one (only one is allowed) system power supply in each separated area. Other power supplies must be auxiliary power supply (323010 or 323005 set as auxiliary power supply).

*Note: 323003 only separate in the direction towards the riser. Never separate from riser to BUS!*

# Power supply installation rules

## LEGEND

- One 323005 is needed in the main network area
- One 323005 is needed in the green area of the unit
- One 323005 is needed in the blue area connected to - 323019



During installation of the system, two power supply solutions can be chosen according to different situations.

**RECOMMENDED PWS SOLUTION AND RELATED CONFIGURATION**

NO.	INSTALLATION STATUS OF SYSTEM		POWER SUPPLY SOLUTION	CONFIGURATION WHEN POWER SUPPLY IS SYSTEM POWER SUPPLY (impedance switch of Power supply must be ON)						CONFIGURATION OF POWER SUPPLY & A POWER SUPPLY when Power supply is assistant power supply (impedance switch of Power supply must be OFF)					
	alarm	Small EP		CF1 ~ CF3 (NNN)	CF4 ~ CF11	CF12  (Type)	CF13  (ASR)	CF14  (M)	CF15  (LE)	CF1 ~ CF3 (NNN)	CF4 ~ CF11	CF12  (Type)	CF13  (ASR)	CF14  (M)	CF15  (LE)
1	None	None	1	X	X	X	X	X	X	Under these four condition, using auxiliary power supply no need configurate					
2	None	None	1	X	X	X	X	X	X						
3	have	None	1	X	X	X	X	X	X						
4	have	None	1	NNN	X	1	0.2~9	1	X						
5	None	have	2	NNN	√	1	1	0/1	X	X	√	2	1	0/1	X
6	None	have	2	NNN	√	1	1	0/1	X	X	√	2	1	0/1	X
7	have	have	2	NNN	√	1	0.2~9	0/1	X	X	√	2	0.2~9	0/1	X
8	have	have	2	NNN	√	1	0.2~9	0/1	X	X	√	2	0.2~9	0/1	X

**Note:**

(X:) It means no configurator is needed and the configuration position is 0; others need a configurator with corresponding value.

(√:) It means configuration is needed. For the configuration procedure refer to the system configuration chapter.

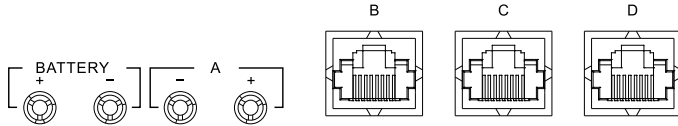
CF1~CF15 is the configuring position for 323005. For the detailed meaning and configuration method please check the system configuration chapter.

# Power supply installation rules

## CONNECTION AND SETUP PROCEDURE FOR 323005

(Set 323005 as system power supply)

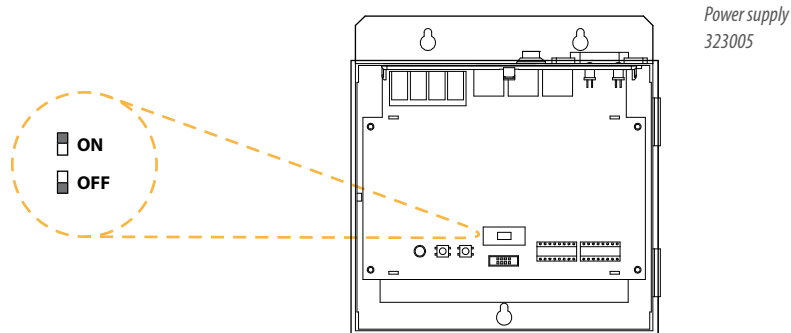
Connector for 323005



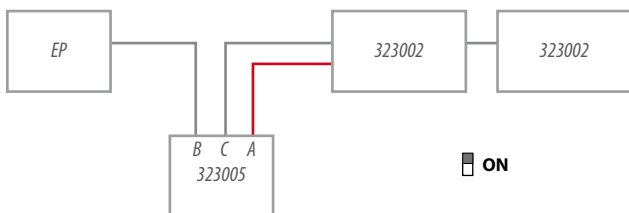
Difference for each connector

	LINE COLOUR	POWER CONNECTION	VIDEO CONNECTION	AUDIO CONNECTION	DATA CONNECTION
		✓			
		✓	✓	✓	✓
		✓	✓	✓	✓
			✓	✓	✓

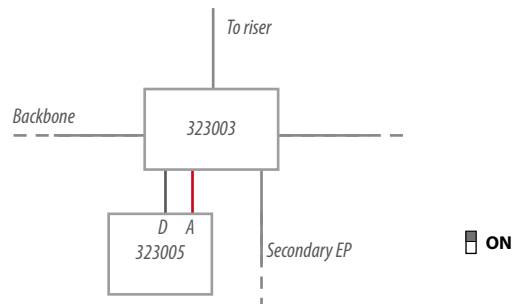
Impedance switch



1) When there is no riser shunt in the system , the system power supply should be connected and set as following drawing:

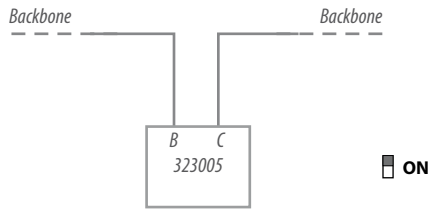


2) When there is riser shunt in the system , the system power supply should be connected and set as following drawing:

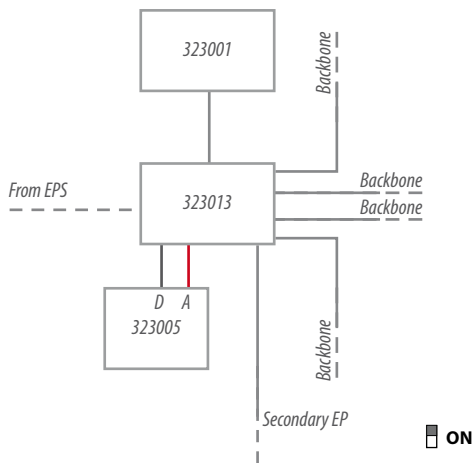


**CONNECTION AND SETUP PROCEDURE FOR 323005**

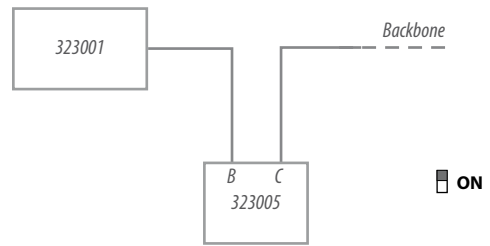
3) When there is no 323013 on the system BUS , the system power supply on the BUS should be connected and set as per the following drawing:



4) When there is no 323013 on the system BUS , the system power supply on the BUS should be connected and set as per the following drawing:



5) When there is a Switchboard in the system, 323001 will get power from system BUS power supply. The system BUS power supply should be connected and set as per the following drawing:

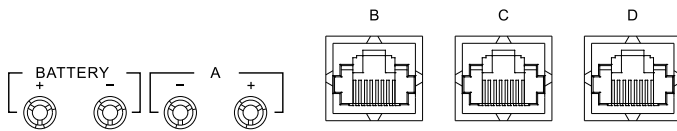


# Power supply installation rules

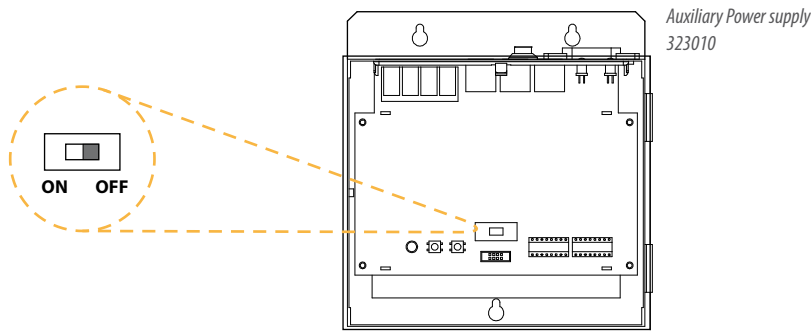
## CONNECTION AND SETUP PROCEDURE FOR 323005

( set PWS as additional power supply) or 323010

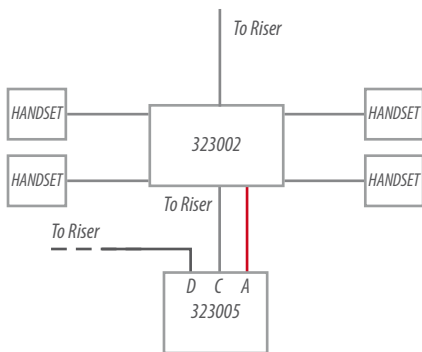
Connector for 323005 and 323010



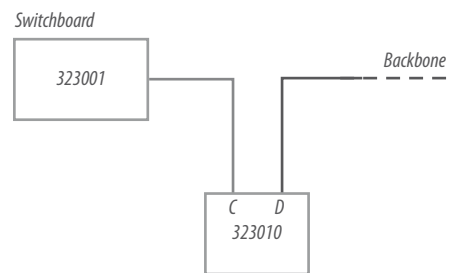
1. 323010 doesn't have an impedance setting switch, and can only be used as auxiliary power supply.
2. if using 323005 as auxiliary power supply, the impedance setting switch of 303005 must be switched to off as per the following drawing:



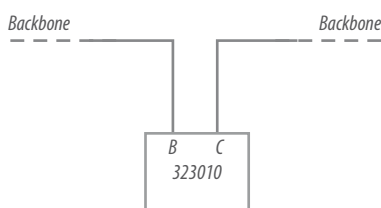
1) the connection of the auxiliary power supply inside the riser:



3) When there is a Switchboard in the system, the Switchboard will get power from the BUS system auxiliary power supply. Connection should be as per the following drawing:



2) When system Bus needs auxiliary power supply, the connection should be as follows:



## Power supply check and calculation

Before proceeding to the system installation, it is necessary to check the power supply of the whole system:

1. Check that the power supplies are enough to supply the power current needed by the devices to install the system;
2. Check that the distance (in meters of cable) between power supply and devices allows the devices to get enough power supply voltage to work correctly.
3. Maximum distance between Floor shunt and handset  
Maximum distance = 50m (CAT5 Cable);

### TYPE OF HANDSETS

The video handset can be of different types depending on the power consumption:

TYPE OF HANDSETS	1	2	3	4	5	6	7	8	9	10	11	12
B/W	●	●	●	●	●	●						
Colour							●	●	●	●	●	●
With alarm		●	●		●	●		●	●		●	●
With secondary entrance panel				●	●	●				●	●	●
100mA current alarm sensor			●			●			●			●
300mA current alarm sensor		●			●			●			●	

The maximum quantity of handsets and EP that the riser system power supply can accept:

TYPE OF HANDSETS	1	2	3	4	5	6	7	8	9	10	11	12
1 EP + Riser shunt (without A/C)	40	4	12	4[*1]	[*N]	4[*2]	52	4	12	24 [*1]	4[*1]	4[*1]
2 EP + Riser shunt + Entrance panel + video mixer (without A/C)	32	4	8	4[*1]	[*N]	4[*2]	44	4	12	20 [*1]	[*N]	4[*1]
3 EP + Riser shunt + Entrance panel + video mixer (without A/C)	28	4	4	[*N]	[*N]	4[*2]	38	4	8	12 [*1]	[*N]	[*N]
4 EP + Riser shunt + Entrance panel + video mixer (without A/C)	24	[*N]	4	[*N]	[*N]	[*N]	36	4	8	8 [*1]	[*N]	[*N]
5 EP + Riser shunt + Entrance panel + video mixer (without A/C)	20	[*N]	4	[*N]	[*N]	[*N]	36	4	4	4 [*1]	[*N]	[*N]
1 EP + Riser shunt (with A/C)	36	4	8	4[*1]	[*N]	4[*2]	48	4	12	20 [*1]	4[*1]	8[*1]
2 EP + Riser shunt + Entrance panel + video mixer (with A/C)	24	[*N]	4	[*N]	[*N]	[*N]	36	4	8	8 [*1]	[*N]	4[*1]
3 EP + Riser shunt + Entrance panel + video mixer (with A/C)	16	[*N]	4	[*N]	[*N]	[*N]	28	[*N]	4	4 [*1]	[*N]	4[*1]
4 EP + Riser shunt + Entrance panel + video mixer (with A/C)	4	[*N]	[*N]	[*N]	[*N]	[*N]	16	[*N]	4	[*N]	[*N]	4[*1]
5 EP + Riser shunt + Entrance panel + video mixer (with A/C)	[*N]	[*N]	[*N]	[*N]	[*N]	[*N]	4	[*N]	[*N]	[*N]	[*N]	[*N]

## Power supply check and calculation

**TABLE 1**

\*N: in this condition (EPs quantity), the riser system power supply cannot provide current to this kind of handset, an additional power supply must be used.

\*1: 2 small EP and 1 EP can work at the same time with handsets connected to the same power supply

\*2: 1 small EP and 1 EP can work at the same time with handsets connected to the same power supply

The information of table is based on below condition

- 50 m cable from Floor shunt to handset and 5m cable between floors.
- 0.5 m cable between Floor shunt and Floor shunt in same floor for the projects with more than one floor shunt on each floor.
- Between Power supply and 1st Floor shunt or riser shunt, for the connection use 2 wire cables.
- Type of door lock release for EP is DC12 V/1 A., release time 100 ms or less. The door lock does not need power during.

- When using an entrance panel video mixer in the riser (more than one EP in the riser), the distance between entrance panel video mixer and riser shunt is 0.5 m.
- The data listed in above table are the requirements based on 4 apartments per floor. For example: if riser use type of handset, and there is only one EP without a/C, then we could found that this system power supply can afford other 40 handsets except EP and riser shunt according to above table. But these 40 handsets need to be arranged as 4 apartments per floor. if the height of each floor is 5 m, the height limit should be applied at the same time, which means  $(40/4 - 1) * 5 = 45$  m
- If the riser EP get power from an auxiliary power supply, the riser system power supply only provide power to riser shunt, the Floor shunt and the handsets.

Maximum distance between EP or handset and power supply.

In the riser, the quantity of devices managed by a power supply are shown in table 4, table 5, and table 6.

Case 1, case 2, case 3, case 4, case 7, case 8, case 9 are for 323005(PW1) and 323010(aPW1). Case 4, case 5, case 6, case 10, case 11, case 12 are for 323005(PW1)

Notes:

- The current can also be affected by the distance. Here every floor is supposed to be 5 m height.
- If there are many 323002, it is supposed that the distance of 323002 is 0.5 m.

Table 4: Case 1 to Case 4, the quantity of devices managed by 323005(PW1)

How many apartments on every floor	HANDSET							
	Case 1		Case 2		Case 3		Case 4	
	Total Qty of handsets	Floor limit	Total Qty of handsets	Floor limit	Total Qty of handsets	Floor limit	Total Qty of handsets	Floor limit
2 apartments/floor (Don't use extra power cable)	24	max: 12 floors	4	max: 2 floors	16	max: 8 floors	10[*1]	max: 5 floors
2 apartments/floor (use extra power cable)	78	max: 39 floors	-	-	16	max: 8 floors	20[*1]	max: 10 floors
4 apartments/floor	40	max: 10 floors	4	max: 1 floor	16	max: 4 floors	12[*1]	max: 3 floors
8 apartments/floor	56	max: 7 floors	4	max: 1 floor	16	max: 2 floors	12[*1]	max: 2 floors
12 apartments/floor	56	max: 5 floors	4	max: 1 floor	16	max: 2 floors	12[*1]	max: 1 floor
16 apartments/floor	56	max: 4 floors	4	max: 1 floor	16	max: 1 floor	16[*1]	max: 1 floor
20 apartments/floor	68	max: 4 floors	4	max: 1 floor	16	max: 1 floor	20[*1]	max: 1 floor
24 apartments/floor	68	max: 3 floors	4	max: 1 floor	16	max: 1 floor	20[*1]	max: 1 floor
28 apartments/floor	68	max: 3 floors	4	max: 1 floor	16	max: 1 floor	20[*1]	max: 1 floor
32 apartments/floor	68	max: 3 floors	4	max: 1 floor	16	max: 1 floor	20[*1]	max: 1 floor
36 apartments/floor	68	max: 2 floors	4	max: 1 floor	16	max: 1 floor	20[*1]	max: 1 floor

Table 5: Case 1 to Case 4, the quantity of devices managed by 323005(Power supply)

How many apartments on every floor	HANDSET							
	Case 5		Case 6		Case 7		Case 8	
	Total Qty of handsets	Floor limit	Total Qty of handsets	Floor limit	Total Qty of handsets	Floor limit	Total Qty of handsets	Floor limit
2 apartments/floor (Don't use extra power cable)	4[*2]	max:2 floor	8[*2]	max:4 floor	36	max: 18 floors	8	max: 4 floors
2 apartments/floor (use extra power cable)			8[*2]	max: 4 floors	90	max: 45 floors	8	max: 4 floors
4 apartments/floor	4[*2]	max: 1 floor	8[*2]	max: 1 floor	56	max: 14 floors	8	max: 2 floors
8 apartments/floor	4[*2]	max: 1 floor	8[*2]	max: 1 floor	72	max: 9 floors	8	max: 1 floor
12 apartments/floor	4[*2]	max: 1 floor	8[*2]	max: 1 floor	76	max: 7 floors	8	max: 1 floor
16 apartments/floor	4[*2]	max: 1 floor	8[*2]	max: 1 floor	80	max: 5 floors	8	max: 1 floor
20 apartments/floor	4[*2]	max: 1 floor	8[*2]	max: 1 floor	80	max: 4 floors	8	max: 1 floor
24 apartments/floor	4[*2]	max: 1 floor	8[*2]	max: 1 floor	80	max: 4 floors	8	max: 1 floor
28 apartments/floor	4[*2]	max: 1 floor	8[*2]	max: 1 floor	80	max: 3 floors	8	max: 1 floor
32 apartments/floor	4[*2]	max: 1 floor	8[*2]	max: 1 floor	80	max: 3 floors	8	max: 1 floor
36 apartments/floor	4[*2]	max: 1 floor	8[*2]	max: 1 floor	80	max: 3 floors	8	max: 1 floor

Table 6: Case 9 to Case 12, the quantity of devices managed by 323005(Power supply)

How many apartments on every floor	HANDSET							
	Case 9		Case 10		Case 11		Case 12	
	Total Qty of handsets	Floor limit	Total Qty of handsets	Floor limit	Total Qty of handsets	Floor limit	Total Qty of handsets	Floor limit
2 apartments/floor (Don't use extra power cable)	16	max: 8 floors	16[*2]	max: 16 floors	4[*3]	max: 1 floor	12[*1]	max: 6 floors
2 apartments/floor (use extra power cable)	16	max: 8 floors	36[*3]	max: 6 floors	4[*3]	max: 1 floor	12[*1]	max: 6 floors
4 apartments/floor	16	max: 4 floors	24[*3]	max: 4 floors	4[*3]	max: 1 floor	12[*1]	max: 3 floors
8 apartments/floor	16	max: 2 floors	32[*3]	max: 3 floors	4[*3]	max: 1 floor	12[*1]	max: 2 floors
12 apartments/floor	16	max: 2 floors	36[*3]	max: 3 floors	4[*3]	max: 1 floor	12[*1]	max: 1 floor
16 apartments/floor	16	max: 1 floor	36[*3]	max: 2 floors	4[*3]	max: 1 floor	12[*1]	max: 1 floor
20 apartments/floor	16	max: 1 floor	36[*3]	max: 2 floors	4[*3]	max: 1 floor	12[*1]	max: 1 floor
24 apartments/floor	16	max: 1 floor	36[*3]	max: 2 floors	4[*3]	max: 1 floor	12[*1]	max: 1 floor
28 apartments/floor	16	max: 1 floor	36[*3]	max: 2 floors	4[*3]	max: 1 floor	12[*1]	max: 1 floor
32 apartments/floor	16	max: 1 floor	36[*3]	max: 2 floors	4[*3]	max: 1 floor	12[*1]	max: 1 floor
36 apartment/floor	16	max: 1 floor	36[*3]	max: 1 floor	4[*3]	max: 1 floor	12[*1]	max: 1 floor

## Power supply check and calculation

\*1 : 2 small EP and 1 EP can work at the same time with handsets connected to the same power supply.

\*2 : 1 small EP and 1 EP can work at the same time with handsets connected to the same power supply.

\*3 : 3 small EP and 1 EP can work at the same time with handsets connected to the same power supply.

The information of table 4 to table 6 is based on the below conditions:

- A) 50 m cable from Floor shunt to handset.
- B) 5 m cable between floors.
- C) 0.5 m cable between Floor shunt and Floor shunt in same floor for the projects with more than one floor shunt on each floor.
- D) Between Power supply and 1st Floor shunt, for the connection use 2 wire cables.
- E) The data in above table also limited by distance. Example: 4 apartment on every floor. Case 1. can have 40 handsets and the Max. per floor is 10. In other words, the distance must less than 45m,  $45m = [(40/4)-1]*5$

In table 4, table 5 and table 6 , in case 4, case 5, case 6, case 10, case 11 and case 12, the quantity of handsets is only for 323005.

If using 323010, Please refer to table 7;

Table 7: 323010 application on case 4, case 5, case 6, case 10, case 11 and case 12

How many apartments on every floor	HANDSET					
	Case 4	Case 5	Case 6	Case 10	Case 11	Case 12
4 handsets/floor	4	2	3	6	4	5
8 handsets/floor	4	2	3	6	4	5
12 handsets/floor	4	2	3	6	4	5
16 handsets/floor	4	2	3	6	4	5
20 handsets/floor	4	2	3	6	4	5
24 handsets/floor	4	2	3	6	4	5
28 handsets/floor	4	2	3	6	4	5
32 handsets/floor	4	2	3	6	4	5

The information of table 7 is based on below conditions:

- A) 50 m cable from Floor shunt to handset.
- B) 5 m cable between floors.
- C) 0.5 m cable between Floor shunt and Floor shunt in same floor for projects with more than one floor shunt on each floor.
- D) Between Power supply and 1st Floor shunt, for the connection use 2 wire cables.
- E) Auxiliary power supply without smart function.
- F) For any types of handsets not listed in table 7 the information is the same as table 4 to table 6.
- G) For all handsets which connect to the same auxiliary power supply the display can be switched on at the same time.

Remark: if small entrance panels are present, the number of devices to be supplied by 323010 may require to use more power supplies, increasing the project cost.

We therefore suggest to use 323005 to setting auxiliary power supply.

# Maximum system limits

DEVICE TYPE	MAX. QTY	REMARKS
Handsets in the whole system (Non-IP network system)	4000	The backbone/main EP can call all the handsets
Handsets in the whole system (IP network system)	4000/each IP area, expandable	The Backbone/main EP can call 4000 users at most while the Switchboard can call all the users.
Handset on each riser	800	323003 can carry 400 handsets at most, but can expand to 800 by connecting item 323019 in series in the unit.
EP on each riser	80	EP codes are available, but by expansion using item 323004, it is possible to connect 25 EPs in total/80 EP.
Backbone/main EP in the whole system (Non-IP network system)	80	1, 2, 3 . . . . .80/The number of the backbone/main EPs in the whole system must start from 1 and must be numbered in succession without gaps: 1, 2, 3.....80
Riser shunt in the whole system (Non-IP network system)	100	
Riser shunt in the whole system (IP network system)	100/each IP area, expandable	
District generator in the whole system (non IP network system)	5	Using level connection with 5 District generators, it can expand 16 networking branch routes.
Switchboards in the whole system,	16	

## VIDEO LIMIT DISTANCE

**Colour Video limit(EP to HANDSET):1 Km, B/W Video limit(EP to HANDSET): 2 Km**

Most of items have the video frequency expansion function. The following figure show How to configure them.

**ON**

**OFF**

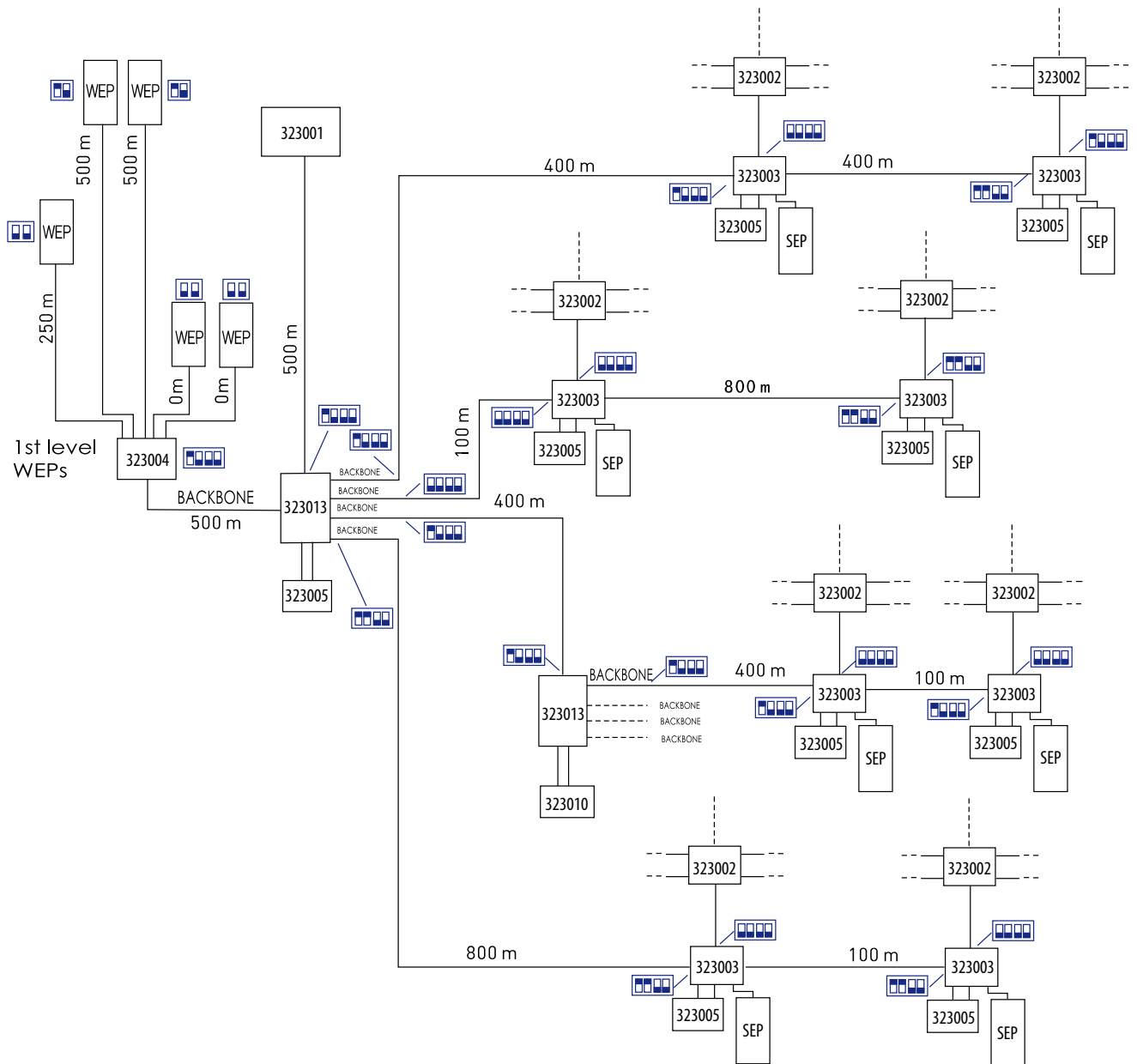
ENTRANCE PANELS				
	Distance	1	2	
<b>COLOUR SIGNAL</b>	0 – 300 m	OFF	OFF	
	300 – 700 m	ON	OFF	
	700 – 1000 m	ON	ON	

RISER SHUNT - VIDEO MIXER - DISTRICT GENERATOR						
	Distance	1	2	3	4	
<b>COLOUR SIGNAL</b>	0 – 300 m	OFF	OFF	OFF	OFF	
	300 – 700 m	ON	OFF	OFF	OFF	
	700 – 1000 m	ON	ON	OFF	OFF	
<b>B/W SIGNAL</b>	1000 – 1500 m	ON	ON	ON	OFF	
	1500 – 2000 m	ON	ON	ON	ON	

*Note: The instruction data in the above table are suggestions for the B/W signal. They may differ during the actual operation. Irrespective of whether it's a colour (less than 1000 m) or B/W signal, please take into account the actual image when setting the data.*

## Maximum system limits

Example for distance limits:



### CASCADE INSTALLATION LIMITS OF VIDEO SIGNAL

After being transmitted by multilevel cascade (insert video amplifier, video splitter etc in transmission channel), the video signal will have distortion and the quality of the image will decrease. **In D45, the maximum level of cascade is 6.** If any of the following devices is passed by a video signal in the system, the cascade level should increase by 1 level. The total level of cascade cannot be over 6.

**INDEX****CONFIGURATION RULES**

General configuration concept . . . . .	96
Entrance panels configuration examples . . . . .	99
Handsets configuration examples . . . . .	101
Accessories configuration examples . . . . .	103

## General configuration concept

### MEANING OF CONFIGURATION

Address codes are the numbers/letters used by residents, visitors and Switchboard operators to identify the apartments or villas in the installation. The D45 system let you use this codes to make calls within the system. The composition of address codes follows the rules below:

Each handset (apartment or villa) of the installation must have one addressing code in order to be called by visitors and the Switchboard. The address code of each apartment depends on the position within the installation.

**Inside the unit/riser each apartment can be addressed with a 4 digit code: FFII**

The first two digits refer to the number of the floor. (F F).

The second two digits refer to the internal number inside the floor: (I I).

The visitor calling the resident from the unit/riser entrance panel has to type these codes (push the button with the code printed on).

**Outside the unit/riser each apartment can be addressed with a code consisting of 8 digits maximum: DDDD FFII.**

The first four digits can be used in a flexible way to identify the unit/riser inside the installation: DDDD may refer to district/building address or building/unit address according to specific installation needs. In smaller installation less digits can be used (from 1 to 4).

The other four digits are the same of the addressing inside the unit/riser (F F I I).

The visitor calling the resident from the wall entry panel or the main Switchboard has to type all the codes (minimum 5 - maximum 8).

**Each digit can be a number from 0 to 9 or a letter from A to J (no mix of the two in the same digit).**

The DDDD address can also be replaced by meaningful words (flowers, etc.): in this case the visitor / user of the Switchboard must find the right name in the directory. (Only possible if the building main entrance panel and the Switchboard are configured from the PC).

### SYSTEM CONFIGURATION

*In order to allow:*

- Visitors / Switchboards to issue the calls to the right handset (example using addressing codes);
- Residents to issue the call to the intended Switchboard;
- Right management of SOS push buttons, alarms pick up; (Identify the apartment that issued the alarm, send the alarm to the right Switchboard);
- Self-powering of the right building main EP or secondary EP from apartment and Switchboard;
- Some devices of the system must be configured.

*The configuration consists of two activities:*

- Decide the right numbers to obtain the intended function (a design/project activity).
- Teach to the physical device its proper configuration (an installation activity)

Both of these activities can be made easier by using a PC software– none of them needs it. As the complexity of the systems grows (in terms of topology and/or user function required) the advantage of using a PC to perform these activities also grows.

### CONFIGURATION DESIGN

The configuration of the system is as close as possible to the address codes, not worrying installers with unusual rules. The configuration method is flexible, and offer two different configuration procedures: each configuration procedure can be applied to different types of installations (changing their limits/systems possibilities):

*Simplified configuration:*

- Avoid using the PC;
- Can only be used if units/riser have a number of floors and handsets for each floor set by us during specification of the "D45".

*Flexible configuration:*

- A PC can be used (but not mandatory) to simplify the installation project (not needed during the installation);
- Can be used if units/risers have a number of floors and handsets that don't differ much from one another. (A table can explain when an installation can be configured in this way).

### SIMPLIFIED CONFIGURATION

*It is compulsory to configure:*

1. Audio/video doorphone handsets. For each handset, its F F I I address code must be configured, starting from flat number 1 and from floor number 1.
2. (riser shunt). Each riser shunt must be configured in a progressive way starting from 1.

If in the entrance panel or Switchboard the progressive riser shunt address is used as the lowest two digits of DDDD, no configuration of the apartment/villa to call is needed in the Wall entrance panel or Switchboard. If the customer wants a complete DDDD address to call the apartment/villa, an association must be performed on the wall entrance panel and on the Switchboard between the riser shunt progressive address and the DDDD requested by the user.

No PC support is needed/useful for these activities.

Using this configuration only the default apartment functions are available.

**With the simple configuration maximum 4000 apartments can be installed:**

40 riser shunts (unit/riser)	25 floors	4 handsets/floor
<i>Alternatively we can have:</i>		
16 riser shunts (unit/riser)	40 floors	6 handsets/floor
25 riser shunts (unit/riser)	40 floors	4 handsets/floor
22 riser shunts (unit/riser)	30 floors	6 handsets/floor
20 riser shunts (unit/riser)	25 floors	8 handsets/floor
or others ...].		

The simplified configuration can be applied to a standard installation or to a district of a multichannel installation inheriting the limits of the chosen configuration type.

### FLEXIBLE CONFIGURATION

Before configuring the system two numbers must be decided:

- #FF maximum number of floors of the units/risers of the installation.  
(a two digit number typical of the installation – max value 99).
- #II maximum number of apartments of the floors in the installation.  
(a two digit number typical of the installation – max value 99).

*It is compulsory to configure:*

1. Audio/video doorphone handsets. For each handset, its F F I I address code must be configured, starting from flat number 1 and from floor number 1 and the typical installation #ii number.
2. Riser shunt. each riser shunt must be configured progressively starting from 1 and the and the typical installation #ii number.
3. Wall entrance panel and Switchboard. In each wall entrance panel and Switchboard, the #FF and #ii installation numbers must be configured.

If in the entrance panel or Switchboard the progressive riser shunt address is used as the lowest two digits of DDDD, no configuration of the apartment/villa to call is needed in the Wall entrance panel or Switchboard. If the customer want a complete DDDD address to call the apartment/villa, an association must be performed on the wall entrance panel and on the Switchboard between the riser shunt progressive address and the DDDD requested by the user. Using this configuration only the default apartment functions are available.

A PC is not needed to configure the system on the installation - it can be used during the project phase to easily identify and check if it is possible to configure the system following the flexible configuration method – it is an alternative to the table below.

**The flexible configuration can be used in installation of up to 4000 apartments, with the maximum limits listed in the linked table** (that can be shared with the people in charge of the configuration – and can be completed using how much row we want to communicate).

NUMBERS OF RISER SHUNTS	NUMBERS OF FLOORS #FF	NUMBERS OF FLATS/FLOOR #II	NUMBER OF APART. IN EACH UNIT/RISER
99	10	4	40
20	50	4	200
11	90	4	360
66	10	6	60
13	50	6	300
7	90	6	540
50	10	8	80
10	50	8	400
5	90	8	720
25	10	16	160
5	50	16	800
12	10	32	320
6	20	32	640

The simplified configuration can be applied to a simplified installation or to a district of the complete installation, inheriting the limits of the chosen configuration type.

### DEFAULT BEHAVIOUR OF APARTMENT FUNCTIONS

The default functions are available both with simplified and flexible system configuration.

The default functions are:

- Self-powering of the main riser EP;
- Repeated pression on self power on function changes on next address riser EP;
- Call to Switchboard is to main Switchboard;
- Alarm collected by main Switchboard.

# General configuration concept

## PHYSICAL CONFIGURATION (INSTALLATION)

The devices may be configured in three ways:

- Use of physical configurators: this means placing the right numbered configurators in the devices in the right position (depending on the design of the configuration).
- Define a procedure of configuration of each device that uses its resources (keypad, LCD, LEDs, etc. ) in order assign to the device the designated number.
- Use the PC on the field to download the results of the design configuration done on a PC, on to each device using its MAC address.

TOTAL NUMBER OF APARTMENTS IN THE INSTALLATION:	VIRTUALLY NO LIMITS
Number of apt. for each "district" (ASO2: LAN-8Wire interface)	4.000 apt. or villas.
Total number of units/riser for each district	400
Total number of apt./villas for each riser:	800 (if only 1 handset in each apt.)
Total number of apt./villas for each riser:	400 (if only 2 handsets in each apt.)
Total number of apt./villas for each riser:	265 (if only 3 handsets in each apt.)
Total number of apt./villas for each riser:	800 (up to 5 handsets in each apt. with D45 apt. interface)

## CONFIGURATION MODE FOR THE WHOLE SYSTEM

Two configuration modes available, configuration mode 1 and configuration mode 2. The main characteristics for each configuration mode are described below:

\*1\*: Below are the rules for system configuration (Mode 1).

#FF FOR EACH RISER	#II FOR EACH FLOOR	CAN SYSTEM CONFIGURATION MODE 1 BE USED?
≤ 20	≤ 4	YES, but it is necessary to calculate the total number of handsets for whole system according to Mode 1 configuration. If the total number calculated is 4000 or less, Mode 1 configuration is possible, if the total number is over 4000, Mode 2 must be considered.
> 20	≤ 4	NO
≤ 20	> 4	NO
> 20	> 4	NO

\*2\*: Below is an example explaining the rules for system configuration (Mode 2):

For example: if the highest building of a project has 25 floors, and the max. number of apartment for floor is 8, with 15 risers in total. Then for mode 2, the #FF should be 25, while

#II should be 8. Make the calculations according to following table to judge if mode 2 configuration can be used.

#FF FOR EACH RISER	#II FOR EACH FLOOR	TOTAL RISER	CAN SYSTEM CONFIGURATION MODE 2 BE USED?
25	8	15	$25 * 8 * 15 = 3000$ $3000 < 4000$ $30 - 25 * 8 * 30 = 6000$ $6000 > 4000$

## HOW TO CHOOSE THE RIGHT CONFIGURATION MODE

- The biggest #FF number in the whole system ≤ 20, the biggest #II number in the whole system ≤ 4, and the number of risers ≤ 50: system configuration Mode 1 is recommended.
- If the biggest #FF number in whole system is more than 20, or the biggest #II number is more than 4, please use system configuration Mode 1 to set #FF (choose the biggest #FF number in the system) and #II (choose the biggest #II number in the system), then calculate the total number of handsets in the system. If the total number ( $\#FF * \#II * R$ ) is 4000 or less, use system configuration Mode 2.

## SYSTEM CONFIGURATION MODES

There are 3 possible system configuration modes:

- Resistor configuration
- Local keyboard configuration
- Configuration using the configuration software, then download to the devices using the RS232 port

Remarks:

For the 3 above configuration modes, the parameters to configure are the same, therefore it is not necessary to describe the configuration procedures separately. Below is an explanation of the resistor configuration as an example. The keyboard configuration is described in the product manual. The configuration using the RS232 port is described in the configuration software manual.

## DEVICE RESISTOR CONFIGURATION



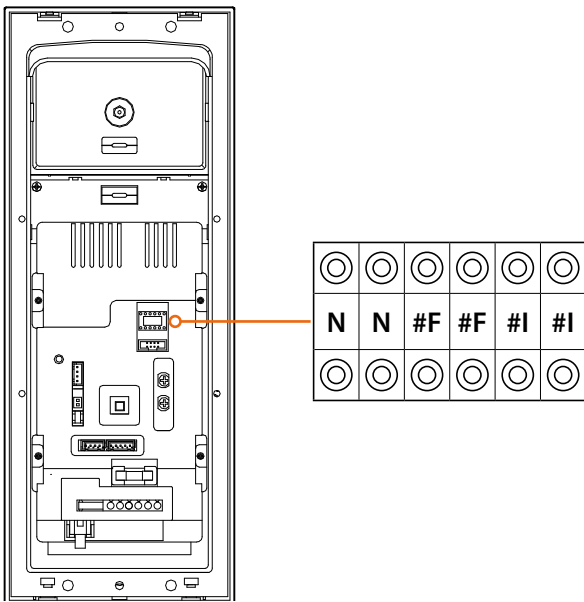
# EP configuration examples

## 322010 - DIGITAL ENTRANCE PANEL CONFIGURATION

### POSSIBLE EP CONFIGURATION MODES

	MODE 1	MODE 2
Resistor configuration	√	√
Keyboard configuration	√	√
RS232 configuration	√	√

### CONFIGURATORS POSITION FOR EP



Note: the other configuration position C is for setting the Switchboard address number that will communicate with the EP directly. The configuration position C can only be configured using the EP keyboard or the configuration tool software. (C default value: 0; this means that the Switchboard that will communicate with the EP is No.0)

### MEANING OF EACH CONFIGURATOR SOCKET PIN

POSITION	MODE 1	MODE 2
N	NN	Mode 2= Mode 1
N	#FF is 20(default). No need for configuration	#FF ( use EP keyboard config or 323020 download config)
	#II is 4(default). No need for configuration	use EP keyboard config or 323020 download config)

NN: the number for the main EP, the number range is from 1 to 80, which means that the maximum main EP in riser is 80 (default value: 1).

#FF: typical floors per riser

#II: typical number of handsets per floor

Example (A):

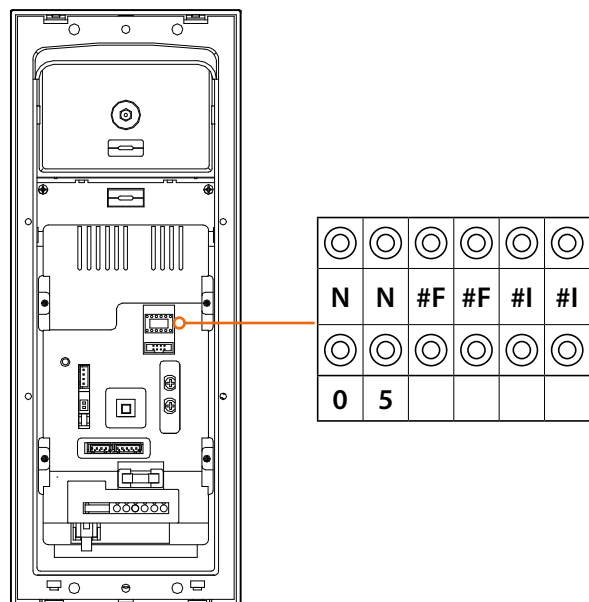
EP address is 5, each riser has 20 floors, and each floor has 4 handset: system configuration mode 1 is used.

The Switchboard directly connected to the main EP is no. 2, main EP configuration should be as follows:

POSITION	VALUE FOR CONFIGURATOR	REMARKS
N	0	0
N	5	
#F		#FF is 20(default).
#F		No need for configuration
#I		#II is 4(default).
#I		No need for configuration

C This position can use the EP keyboard or the configuration tool for the configuration.

A



## EP configuration examples

### 322010 - DIGITAL ENTRANCE PANEL CONFIGURATION

Example (B):

EP address, each riser has 25 floors, and each floor has 8 handsets. System configuration mode 2 is used. the Switchboard directly connected to the main EP is no. 2 MC. Main EP configuration should be as follows:

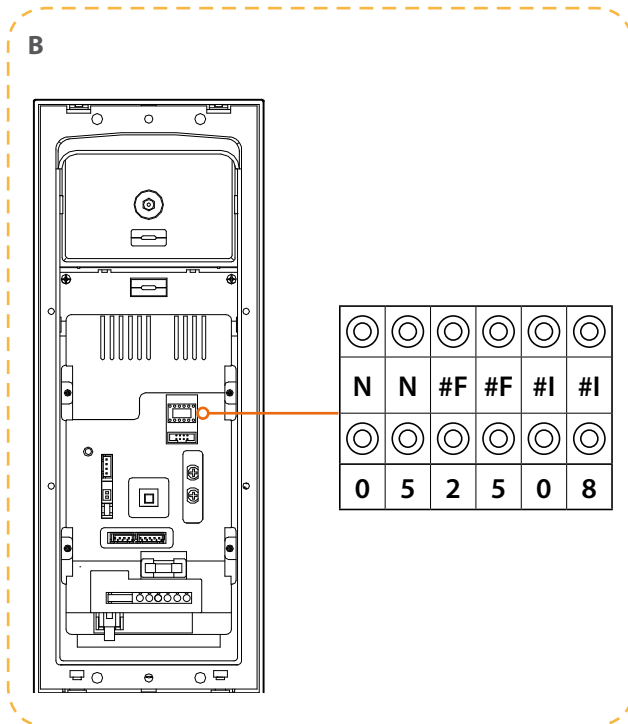
POSITION	VALUE FOR CONFIGURATOR	REMARKS
N	0	It is ok not to insert configurator 0
N	5	
#F	2	
#F	2	
#I	0	It is ok not to insert configurator 0
#I	8	

NOTE: there is an additional configuration slot "M".

M= switchboard address number - can be set only by keyboard or by SF2 software.

If configurator or keyboard configuration is selected for the main EP, the following conditions must be met:

all item 323003 in the system should be numbered in sequence. They must start from 1 and no number can be missed.



# Handset configuration examples

## 321010 - POSSIBLE HANDSET CONFIGURATION PROCEDURE

	MODE 1	MODE 2
Resistor configuration (only for Colour)	√	√
Keyboard configuration	√	√
RS232 configuration	×	×

## MEANING OF EACH CONFIGURATOR SOCKET PIN

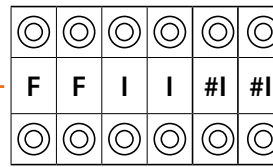
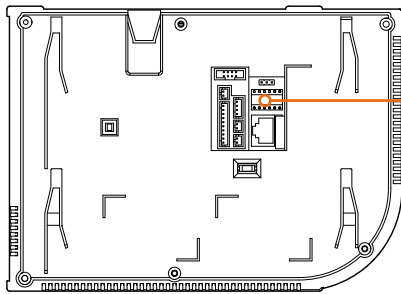
POSITION	MODE 1	MODE 2
F	FF	FF
F		
I	II	II
I		
#I	Default for #II is 04, need not connect the configurator	II
#I		(#II setup using same value for all system handsets).

FF: Handset floor number

II: handset household number

#II: typical number of handsets per floor

### CONFIGURATORS POSITION FOR HANDSETS

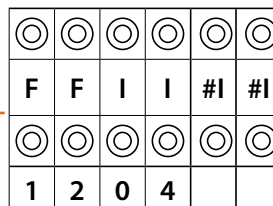
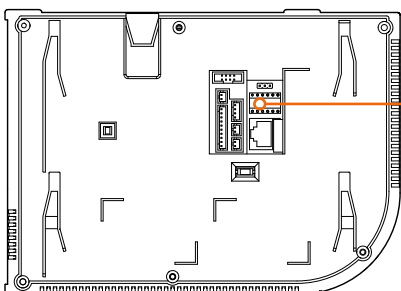


Example (A):

The number of handsets is 1204, each floor has 4 handsets, the system configuration mode is Mode 1, the handset configuration should be as follows:

POSITION	CONFIGURATION VALUE	REMARKS
F	1	
F	2	
I	0	It is ok not to insert configurator 0
I	4	
#I		Because the default value of #II is 4, no configurator is needed
#I		

A



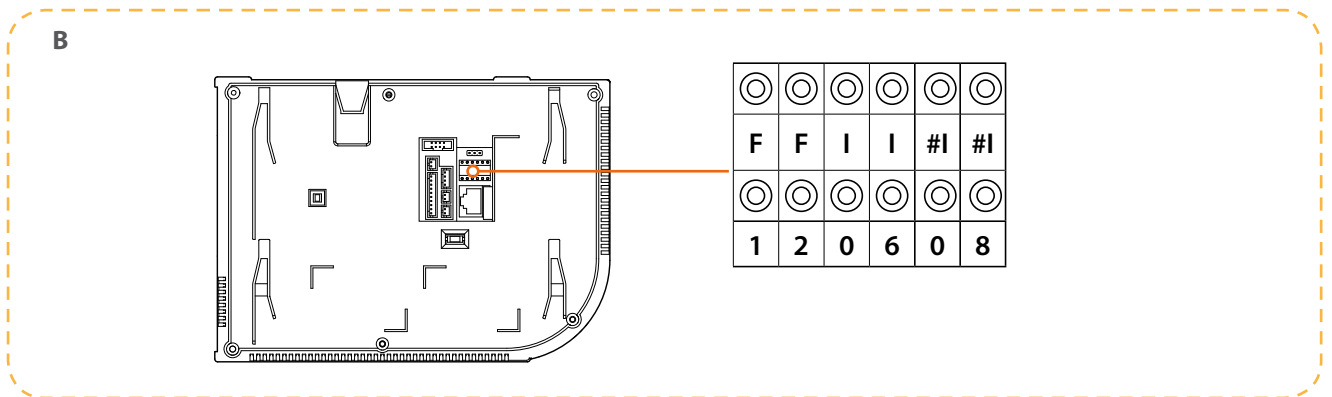
## Handset configuration examples

### 321010 - HANDSET CONFIGURATION

Example (B):

The number of handsets is 1206, each floor has 8 handsets. System configuration mode 2 is used. The handset configuration should be as follows:

POSITION	VALUE	REMARKS
F	1	
F	2	
I	0	It is ok not to insert configurator 0
I	6	
#I	0	It is ok not to insert configurator 0
#I	8	



# Accessory configuration examples

## 323003 - RISER SHUNT CONFIGURATION

### POSSIBLE RISER SHUNT CONFIGURATION PROCEDURE

	MODE 1	MODE 2
Resistance configuration	√	√
Keyboard configuration	√	√
Use RS232 configuration	√	√

### MEANING OF EACH CONFIGURATOR SOCKET PIN

POSITION	MODE 1	MODE 2
CF1	NNNN	NNNN
CF2		
CF3		
CF4		
CF5	#FF is 20(default). No need for configuration	#FF (#II setup using same value for all system riser shunts).
CF6		
CF7	#II is 4(default). No need for configuration	#II (#II setup using same value for all system riser shunts).
CF8		
C	C	C
M	M	M

- NNNN: number of riser shunts
- #FF: typical floor number for riser
- #II: typical number of handsets for each floor
- #Min handset: the lowest handset address managed by this riser shunt.
- #Max handset: the highest handset address managed by this riser shunt.

C: the Switchboard number that is the first priority for this riser. If the number of the Switchboard is more than 9 (from 10 to 15), this parameter can only be set using the riser shunt keyboard or the system configuration software tool.

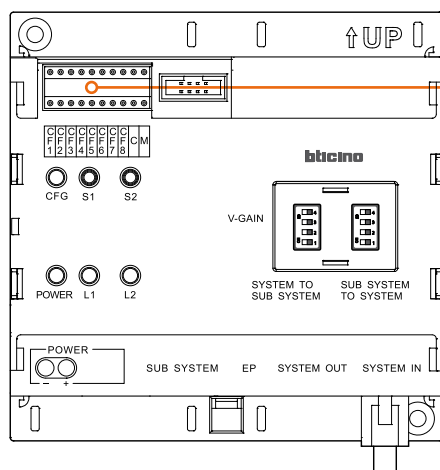
M: System configuration mode. If the selected configuration mode is Mode 1 or mode 2, this parameter is 0. If this configurator is set using number 2, it means that this riser shunt is only used inside the riser to extend the maximum number of handsets (from 400 to 800 ).

If 323011 is present in the system or switchboard is install in the riser than an additional configuration is needed for riser shunt as below listed :

Configuration can only be set by SF2 software or by keyboard.

CONFIGURATION BIT	DEFINITION	REMARK
CF11 CF12	First EP number in this riser	From 1 to 80
CF13 CF14	Riser EP quantity of riser	
CF15 CF16	Riser switchboard number	From 1 to 15

### RISER SHUNT CONFIGURATION POSITION



CF1	CF2	CF3	CF4	CF5	CF6	CF7	CF8	C	M
⊙	⊙	⊙	⊙	⊙	⊙	⊙	⊙	⊙	⊙
N	N	N	N	#F	#F	#I	#I	C	M
⊙	⊙	⊙	⊙	⊙	⊙	⊙	⊙	⊙	⊙

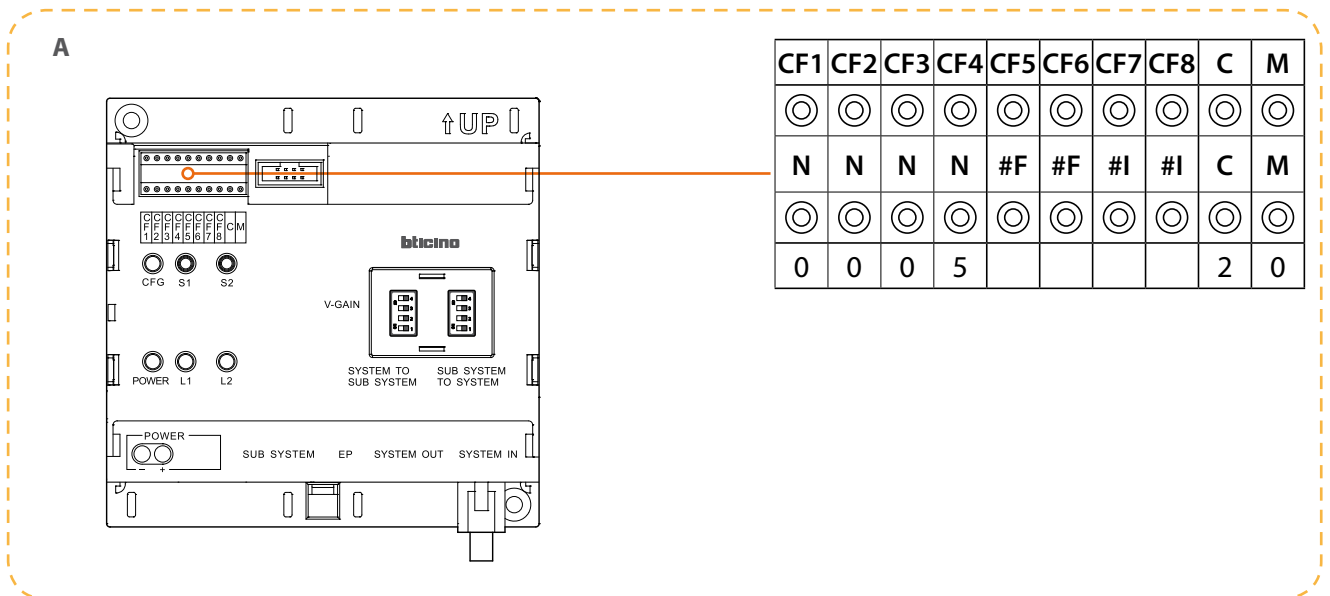
## Accessory configuration examples

### 323003 - RISER SHUNT CONFIGURATION

Example (A):

The number of riser shunts is 5, each riser has 20 floors, and each floor has 4 handsets. The Switchboard that can be called directly by this riser is no. 2. System configuration mode 1 is used. The riser shunt configuration should be as follows:

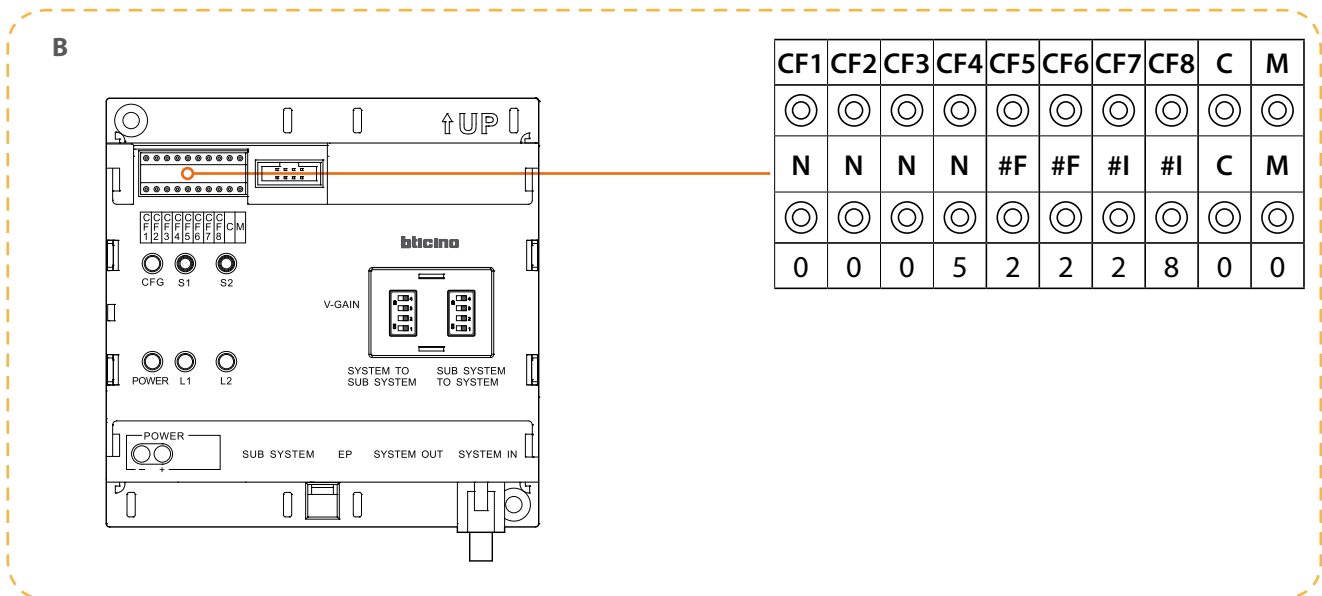
POSITION	MODE 1	VALUE FOR CONFIGURATOR	REMARKS
CF1	N	0	0 no config needed
CF2	N	0	0 no config needed
CF3	N	0	0 no config needed
CF4	N	5	
CF5	#F		#FF is 20(default).
CF6	#F		No need for configuration
CF7	#I		#II is 4(default).
CF8	#I		No need for configuration
C	C	2	
M	M	0	0 no config needed



Example (B):

The number of riser shunts is 5, each riser has 25 floors, and each floor has 8 handsets. The Switchboard that can be called directly by this riser is no. 2 System configuration mode 2 is used. The riser shunt configuration should be as follows:

POSITION	MODE 1	VALUE FOR CONFIG.	REMARKS
CF1	N	0	It is ok not to insert configurator 0
CF2	N	0	It is ok not to insert configurator 0
CF3	N	0	It is ok not to insert configurator 0
CF4	N	5	
CF5	#F	2	
CF6	#F	5	
CF7	#I	0	It is ok not to insert configurator 0
CF8	#I	8	
C	C	0	It is ok not to insert configurator 0
M	M	0	It is ok not to insert configurator 0



## Accessory configuration examples

### 323003 - RISER SHUNT CONFIGURATION

With mode 1 and mode 2, if configurator or keyboard configuration is selected for the riser shunt, the following conditions must be met: all riser shunts in the system should be numbered in sequence. They must start from 1 and no number can be missed.

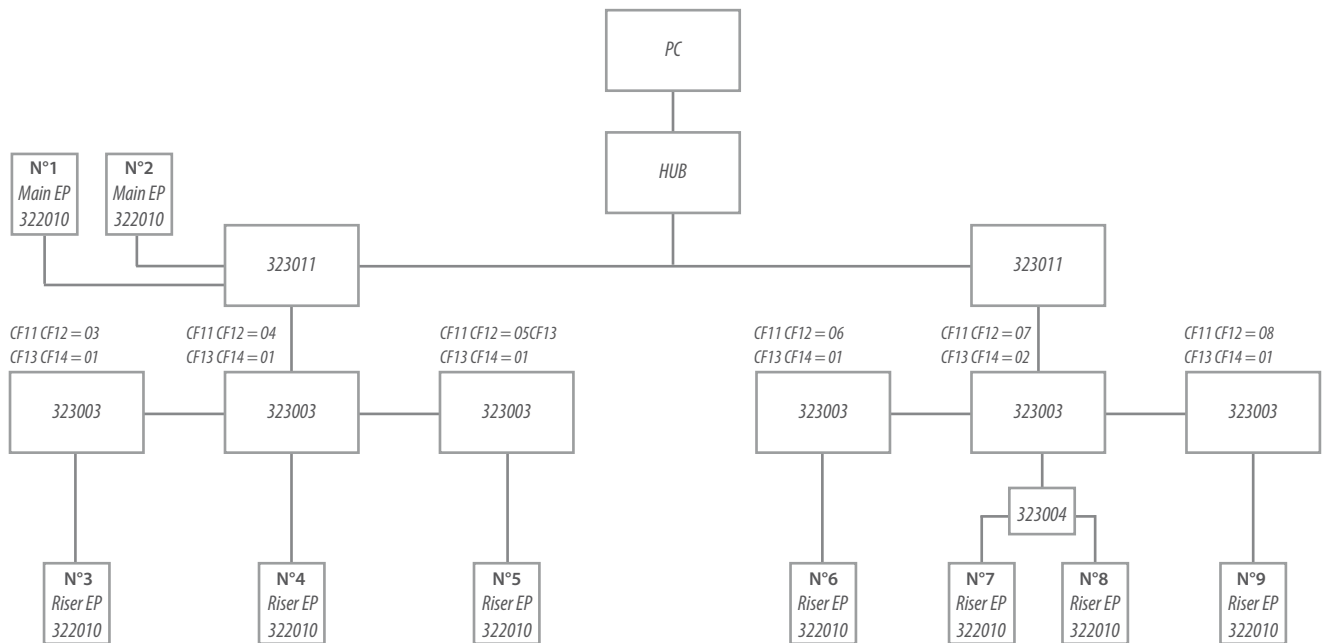
Riser shunt software version V.2 or above includes the EP offset configuration item. This item should be downloaded from 323020 (version on V0.7 or later version have this function). This added configuration is to ensure compatibility between D45 system and BT 2-wire system. If the projects does not require that these two systems be compatible, configuration of this item is not necessary.

EP range of each cell in the D45 system is 1—80. The main EP range is also 1—80, which means that the maximum

number of the main EP in the system is 80, and the main quantity that can be reached is 80\*X (X is the cell quantity). But after D45 and BT 2-wire system compatible, each riser EP and main EP can't separately occupy 1-80 number. The main EP QTY and EP total quantity for all risers cannot exceed 80. This means that the total quantity of riser EP +main EP<=80.

#### Example

If D45 should be compatible with the BT system, there are two D45/IP interfaces used in system. First D45/IP interface-1, to connect 2 main EP and 3 cells (Cell 1, 2, 3), each cell has one EP; second D45/IP interface-2, to connect 0 main EP and 3 cells (cell 4, 5, 6), cell 4 and cell 6 connect to 1 EP each, cell 5 connects to 2 EP.



				323011-1 Entrance panel setting	
EP Device	Riser SCS BUS Address	EP shifting in RS1	Address setting	Backbone SCS BUS Address	
First WEP	1	---	---	1	Lowest address: 1 Highest address: 5
Second WEP	2	---	---	2	
EP of Unit 1	1		2	1+2=3	
EP of Unit 2	1		3	1+3=4	
EP of Unit 3	1		4	1+4=5	
				IT4-2 Entrance panel setting	
EP Device	Riser SCS BUS Address	EP shifting in RS1	Address setting	Backbone SCS BUS Address	
EP of Unit 4	1		5	1+5=6	Lowest address: 6 Highest address: 9
First EP of Unit 5	1		6	1+6=7	
Second EP of Unit 5	2			2+6=8	
EP of Unit 6	1		8	1+8=9	

Note: Riser shunt software version V.2 or above includes the EP offset configuration item. And it can only configure by 323020, meanwhile 323020 version should be on or above V0.7.

**323018-EP/SWITCHBOARD SHUNT CONFIGURATION**

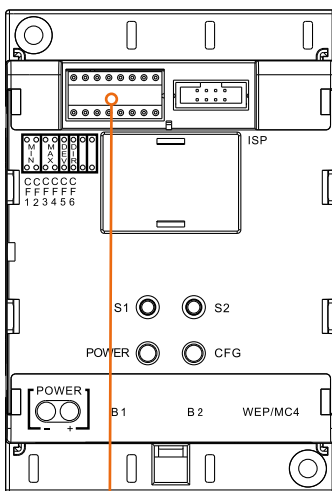
**POSSIBLE CONFIGURATION PROCEDURE**

	MODE 1
Resistor configuration	√
Keyboard configuration	√
RS232 configuration	√

POSITION	MODE 1	VALUE FOR CONFIG.	REMARKS
CF1	MIN	0	x
CF2	MIN	4	x
CF3	MAX	0	x
CF4	MAX	5	x
CF5	DEV	0	x
CF6	DIR	0	x

The 323018 used to extend one Switchboard, Switchboard address range is 4 to 5; all main EP are installed in the B2 port of 323018, configuration as follows:

**CONFIGURATOR POSITION FOR EP/ SWITCHBOARD SHUNT**



CF1	CF2	CF3	CF4	CF5	CF6
⊙	⊙	⊙	⊙	⊙	⊙
MIN	MIN	MAX	MAX	DEV	DIR
⊙	⊙	⊙	⊙	⊙	⊙
0	4	0	5	0	0

**323009 LED INDICATIONS**

*Directions for the configuration:*

Optional configuration alternatives for 323009.

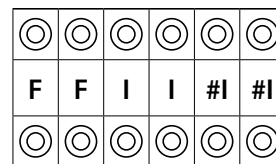
	1/Mode 1	2/Mode 2	Remarks
RESISTOR CONFIGURATION METHOD	√	√	Not inserting the configurator resistor, the value will regard as 0.
PUSHBUTTON ON METHOD	√	√	
RS232 METHOD	√	√	

Remarks. When using item 323009, the room number is configured automatically, no need to set it at the handset.

Press Mode 1 and Mode 2 to select the desired configuration method. The user can select any method based on system complexity and structure. When the physical configurator is inserted, you take the priority and RS232 serial interface and pushbutton configuration ways are disabled (has no effects).

When altering the configurator resistance, press and hold down both the S1 key and the S2 key for more than 2 seconds, until the CFG LED indicator comes on. Release the keys and restart device item 323009 for the new configuration to take effect. If the configuration is correct, the CFG indicator will be off in 20 seconds or it will flash slowly.

*Directions for item 323009 configuration:*



## Accessory configuration examples

### 323009 - APARTMENT INTERFACE

Code for the configuration place  
 Meaning of the configuration place

CONFIGURATION PLACE	MODE 1	MODE 2	DIRECTIONS
CF1	FF	FF	FF is the Device floor number (Tens at the front)
CF2			
CF3	II	II	II means the Device household number (Tens at the front)
CF4			
CF5		#II	#II means the Device household number (Tens at the front): #II is for 0 (or no configuration resistor), the default is 4 households. The building is 20 floors.
CF6			

For 4 houses on each floor and a total of not more than 20 floors, you can configure as per Mode 1 (The floor number is from 1 to 20 and the room number is from 1 to 4); otherwise use mode 2 for the configuration.

**EXAMPLE:**

Note: The configuration value in the following example can be configured with either the configurator or serial RS232.

- A. Apartment interface. There are 20 floors in the 323009 unit, with four houses on each floor. When the house number is 1204, 323009 can be configured as per Mode 1.

CONFIGURATION PLACE	CONFIGURATION VALUE	REMARKS	CONFIGURATION DIAGRAMS
CF1	1	FF=12	
CF2	2		
CF3	0	II=04	
CF4	4		
CF5	0	#II is configured as 0 and the system will default the house number at each floor as 4.	
CF6	0		

- B. If the room number at item 323009 is 1206, and the house number on each floor is 8, then device must be configured as per Mode 2.

CONFIGURATION PLACE	CONFIGURATION VALUE	REMARKS	CONFIGURATION DIAGRAMS
CF1	1	FF=12	
CF2	2		
CF3	0	II=06	
CF4	6		
CF5	0	#II=08	
CF6	8		

## CODE FOR THE CONFIGURATION PLACE

⊙	⊙	⊙	⊙	⊙	⊙
F	F	I	I	#I	#I
⊙	⊙	⊙	⊙	⊙	⊙

### Configuration methods using the pushbuttons

1. Enter into the configuration status: In standby, press key (S2) for 2 seconds to enter configuration mode, the CFG indicator will be on (If the configurator is fitted with a resistor or the pushbuttons are incorrectly configured, access to configuration mode is not possible).
2. Enter the configuration place code (to select a certain place at the configurator): press the S2 key to reach the desired number. At every pressure the code will be increased by one 1 (no pressure will give 1) and the CFG indicator will flash once.
3. Confirm the configuration place code: Press the S1 key and the CFG indicator will flash quickly twice. Then it emit an extended flash to and enter value configuration mode.
4. Enter the configuration place value: Press the S2 key (defaulted at 0). Press once and the value will be increased by 1, the CFG indicator flashing quickly twice.
5. Confirm the configuration place value: Press the S1 key and the CFG indicator will flash quickly twice; than it flashes slowly twice, the value is set.
6. Set the next place: If you need to set the value of other configuration places, press S2 and the CFG indicator will flash 3 times. Then continue from point (2).
7. End the configuration: Press the S1 key to exit configuration mode. If the procedure has been successful the CFG will flash once and then come on steady. The new configuration is now available. If the procedure fails (for example, a certain configuration value is bigger than 9), the CFG indicator will go off and then come back on using the old configuration. If the configuration value is logically wrong (such as II>#II), then on reset the CFG indicator will flash quickly, indicating wrong configuration and pushbutton operation will stop. In this case connect the non-zero (1 to 9) resistor to the configurator and repower to clear all the values configured using the pushbuttons. Remove the resistor, repower and reset following the above steps. If during the operation no pushbutton is pressed for 10 seconds, the unit will automatically exit the configuration status and the CFG indicator will go off.

### Methods for viewing the configuration

(You can only view the information configured with the pushbuttons or RS232).

1. Switch to view status: In standby, press the S1 key for 2 seconds and the CFG indicator will flash slowly and enter configuration view mode (This status is not accessible in case of wrong configuration).
2. Enter the configuration code (to select a certain place at the configurator): press the S2 key to increase the numbers. At every pressure the code will be increased by one 1 (no pressure will give 1) and the CFG indicator will flash slowly twice.
3. Read the configuration value: Press the S1 key and the CFG indicator will flash. The number of times it will flash will depend on the size of the value (For example, if the reading result is 0, it won't flash; if it's 1, it will flash once, and if 2, it will flash twice, and so on), and then move to the next step.
4. With the CFG indicator off, it will exit the configuration view status: If during the operation no pushbutton is pressed for 10 seconds, the unit will automatically exit the status and the CFG indicator will go off.

## Accessory configuration examples

### 323018 - EP/SWITCHBOARD SHUNT CONFIGURATION

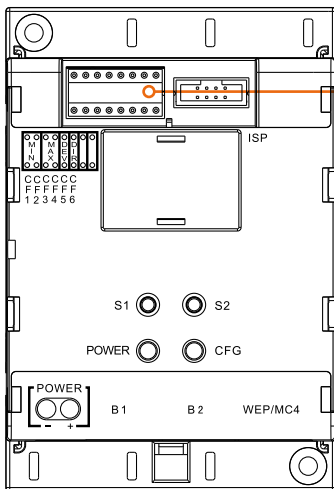
#### POSSIBLE CONFIGURATION PROCEDURE

	MODE 1
Resistance configuration	√
Keyboard configuration	√
Use RS232 configuration	√

POSITION	MODE 1	VALUE FOR CONFIG.	REMARK
CF1	MIN	0	x
CF2	MIN	4	x
CF3	MAX	0	x
CF4	MAX	5	x
CF5	DEV	0	x
CF6	DIR	0	x

The 323018 used to extend one switchboard, switchboard address range is 4 to 5; all main EP are installed in the B2 port of 323018, configuration as follows:

#### CONFIGURATORS POSITION FOR EP/SWITCHBOARD SHUNT



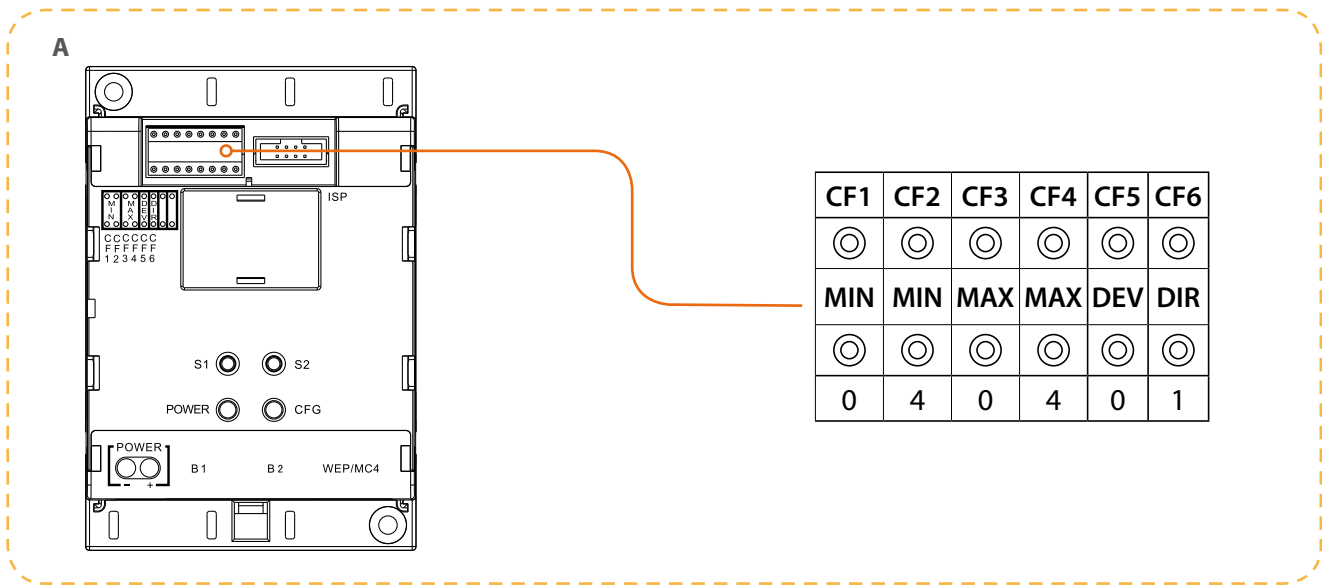
CF1	CF2	CF3	CF4	CF5	CF6
⊙	⊙	⊙	⊙	⊙	⊙
MIN	MIN	MAX	MAX	DEV	DIR
⊙	⊙	⊙	⊙	⊙	⊙
0	4	0	5	0	0

**323018 - EP/SWITCHBOARD SHUNT CONFIGURATION**

Example (A):

Item 323018 is used to extend one Switchboard. The Switchboard address range is 4; all main EP are installed in the B1 port of 323018, configuration as follows:

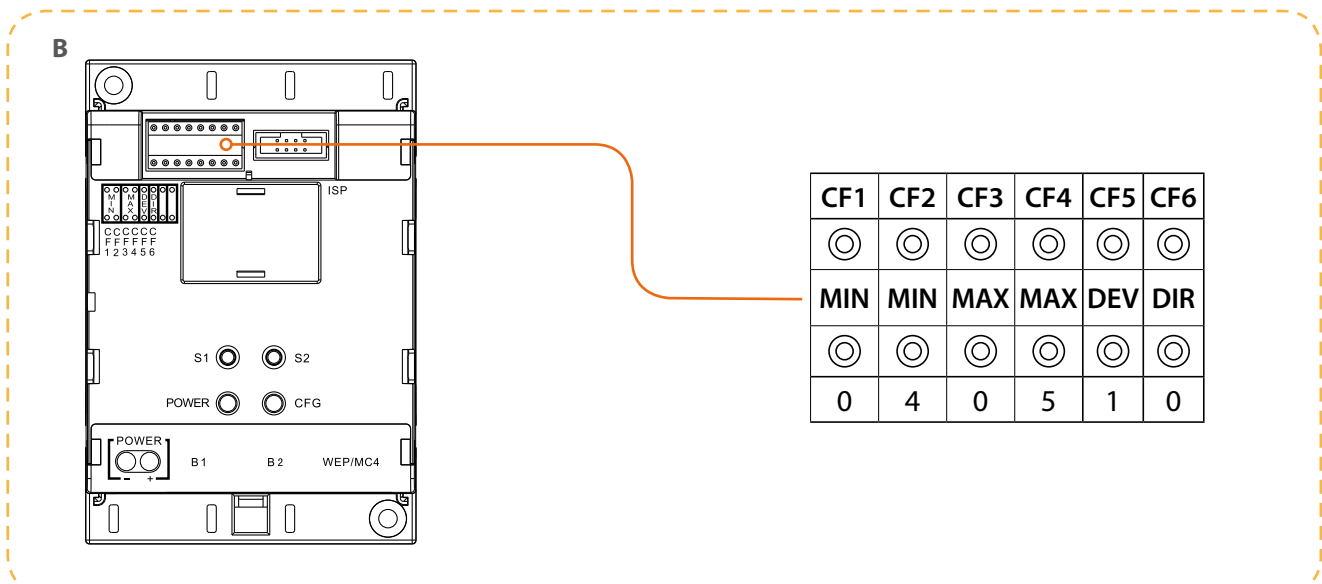
POSITION	MODE 1	VALUE FOR CONFIG.	REMARKS
CF1	MIN	0	x
CF2	MIN	4	x
CF3	MAX	0	x
CF4	MAX	4	x
CF5	DEV	0	x
CF6	DIR	1	x



Example (B):

Item 323018 used to extend the main EP. The main EP address range is 4 to 5; all Switchboards are installed in the B1 port of 323018, configuration as follows:

POSITION	MODE 1	VALUE FOR CONFIG.	REMARKS
CF1	MIN	0	x
CF2	MIN	4	x
CF3	MAX	0	x
CF4	MAX	5	x
CF5	DEV	1	x
CF6	DIR	0	x



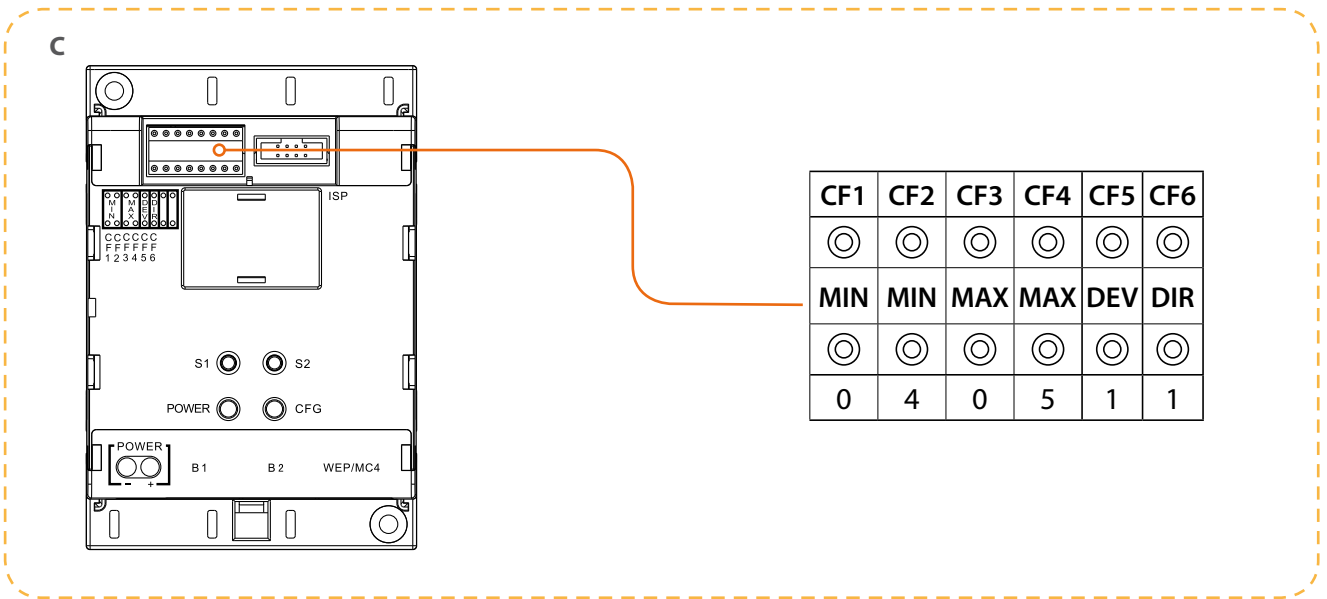
## Accessory configuration examples

### 323018-EP/SWITCHBOARD SHUNT CONFIGURATION

Example (C):

Item 323018 is used to extend one Switchboard, Switchboard address range is 4; all main EP are installed in the B1 port of 323018, configuration as follows:

POSITION	MODE 1	VALUE FOR CONFIG.	REMARKS
CF1	MIN	0	x
CF2	MIN	4	x
CF3	MAX	0	x
CF4	MAX	5	x
CF5	DEV	1	x
CF6	DIR	1	x



**323005 - POWER SUPPLY CONFIGURATION**

**POSSIBLE CONFIGURATION WAY FOR POWER SUPPLY**

	MODE 1	MODE 2
Resistor configuration	√	√
Keyboard configuration	√	√
RS232 configuration	√	√

**MEANING OF EACH CONFIGURATOR SOCKET PIN**

CONFIGURATION	MODE 1 (1 PWS FOR EACH FLOOR)	MODE 2
N	NNN	NNN
N		
N		
CF4	FF Min	FF Min
CF5		
CF6		#II
CF7		
CF8	FF Max	FF Max
CF9		
CF10		
CF11		
Type	Type	Type
ASR	ASR	ASR
M	M	M
LE	LE	LE

**NNN:** Power supply address (range 1–256), only when TYP=1, the power supply address will be valid. It means when TYP=0, there is no need to configure NNN.

**FF Min:** the floor number where this power management starts from.

**FF Max:** the floor number where this power management ends. FF Max must over or equal to FF Min.

**#II:** number of apartments on each floor (at mode 1, the default number is 4, no need to set)

**#Min handset:** the address of the first address managed by this power supply)

**#Max handset:** the last handset address managed by this Power supply)

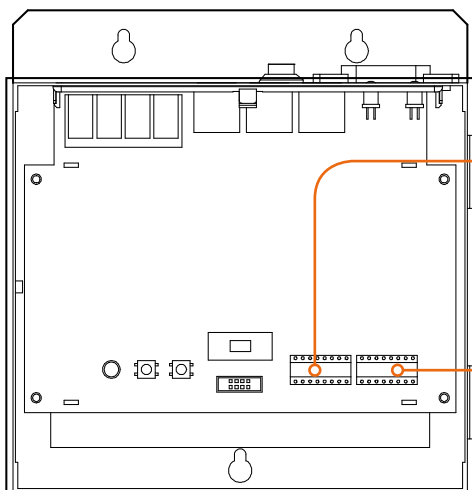
**TYP:** configuration position for the power supply function. Used to enable or disable the power supply management function and the smart power function.

**ASR:** set how much current the power supply will offer to each handset for the alarm function.

**M:** position to choose configuration mode. connecting configurator 0 means choosing mode 1 or mode 2.

**LE:** configuration position for smart power supply management. Only valid when TYP=1. When TYP=0, no need to configure that position.

**CONFIGURATORS POSITION FOR POWER SUPPLY**



N	N	N	CF4	CF5	CF6	CF7
⊙	⊙	⊙	⊙	⊙	⊙	⊙
N	N	N	FF min	FF min	#I	#I
⊙	⊙	⊙	⊙	⊙	⊙	⊙

CF8	CF9	CF10	CF11	TYP	ASR	M	LE
⊙	⊙	⊙	⊙	⊙	⊙	⊙	⊙
FF max	FF max			TYP	ASR	M	LE
⊙	⊙	⊙	⊙	⊙	⊙	⊙	⊙

## Accessory configuration examples

### 323005 - POWER SUPPLY CONFIGURATION

**TYP:** configuration position for the power supply function(√means that this function is available, X means that this function is not available)

TYP	POWER SUPPLY MANAGEMENT FUNCTION	SMART POWER FUNCTION
0	×	×
1	√	√
2	×	√

**Power supply management:**

In the systems with a standby battery (optional), in case of AC power cut the handset will automatically enter energy saving mode, saving energy for the alarm function. For systems with alarm function and standby battery it is recommended that the power supply management is kept on.

**Smart power supply:**

This allows the max quantity of working small EP when power is supplied normally. For projects including small EP, we suggest that the power supply is used as auxiliary power supply and that the smart power supply function is kept on. When type=0, no configuration is necessary.

**ASR:** alarm sinking reserve of each apartment supplied by the PS

ASR = ALARM SINKING RESERVE OF EACH APARTMENT SUPPLIED BY THE PS	
0	300 mA (Default (Max))
1	0 mA
2	50 mA
3	85 mA
4	120 mA
5	150 mA
6	180 mA
7	210 mA
8	240 mA
9	270 mA

**LE:** configuration position for smart power supply function. This position controls when to enter energy-saving mode under different situations.

0 AC is not an not energy saving

1 AC is not an not energy saving

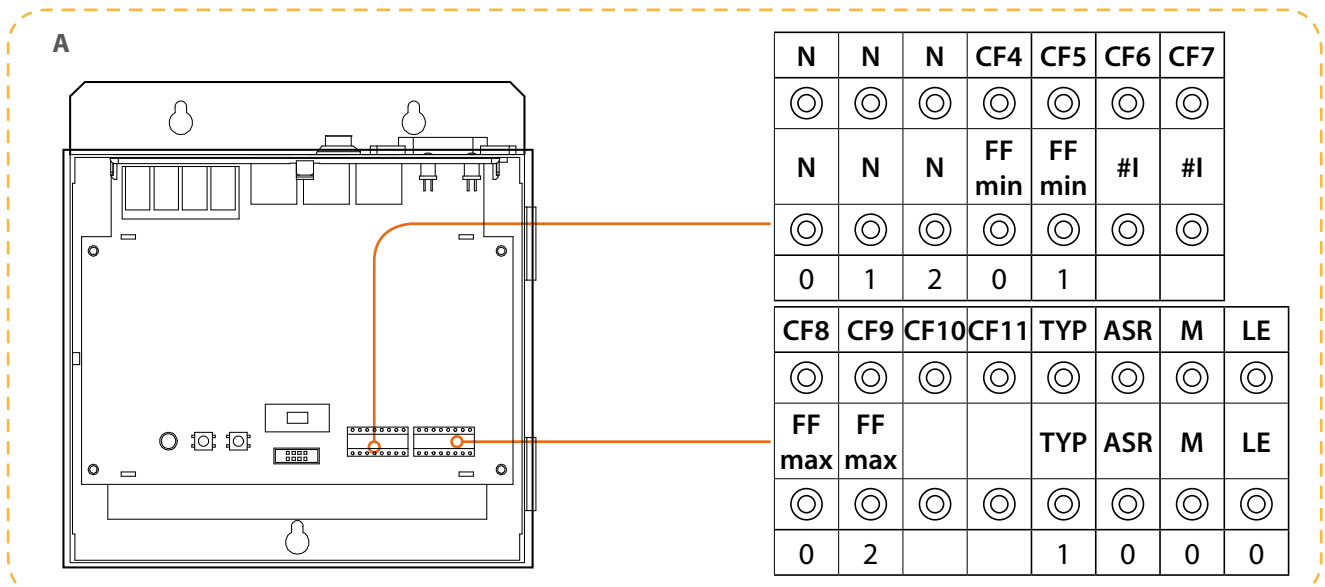
**NOT energy saving:** all the system functions are allowed.

This mode is not Energy saving. Energy saving: parts of the system functions (such as video) are disabled in order to save energy.

Example (A):

This riser has 20 floors, and each floor has 4 handsets. This power supply manages 1-2 floors. If necessary enable the smart power function and power management function, the power supply address is 12, the max current of the alarm sensor is 300 mA. System configuration mode 1 is used. The power supply configuration should be as follows:

POSITION	MODE 1	VALUE FOR CONFIGURATOR	REMARKS
CF1	N	0	
CF2	N	1	
CF3	N	2	
CF4	FF Min	0	
CF5	FF Min	1	
CF6	#I		Default is 4 apartments. 0 means 4 apartments0.
CF7	#I		
CF8	FF Max	0	
CF9	FF Max	2	
CF10	CF10		For mode 1 and mode 2, CF10 and CF11 do not apply
CF11	CF11		
CF12	Type	1	
CF13	ASR	0	
CF14	M	0	
CF15	LE	0	

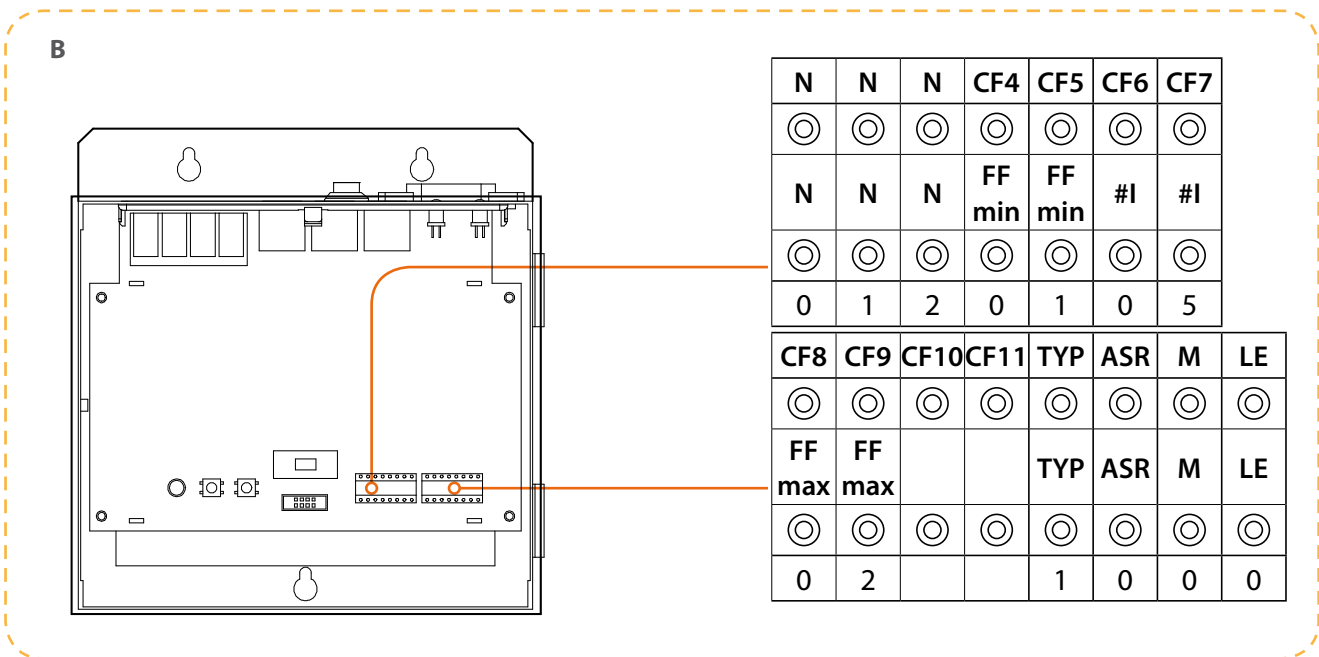


**323005 - POWER SUPPLY CONFIGURATION**

Example (B):

This riser has 20 floors, and each floor has 5 handsets. This power supply manages 1-2 floors. If necessary enable the smart power function and the power management function, the power supply address is 12, max current of the alarm sensor is 300 mA. System configuration mode 2 is used. The power supply configuration should be as follows:

POSITION	MODE 1	VALUE FOR CONFIGURATOR	REMARKS
CF1	N	0	
CF2	N	1	
CF3	N	2	
CF4	FF Min	0	
CF5	FF Min	1	
CF6	#I	0	
CF7	#I	5	
CF8	FF Max	0	
CF9	FF Max	2	
CF10	CF10		Here configuration is not necessary for mode 1 and mode 2
CF11	CF11		
CF12	Type	1	
CF13	ASR	0	
CF14	M	0	
CF15	LE	0	



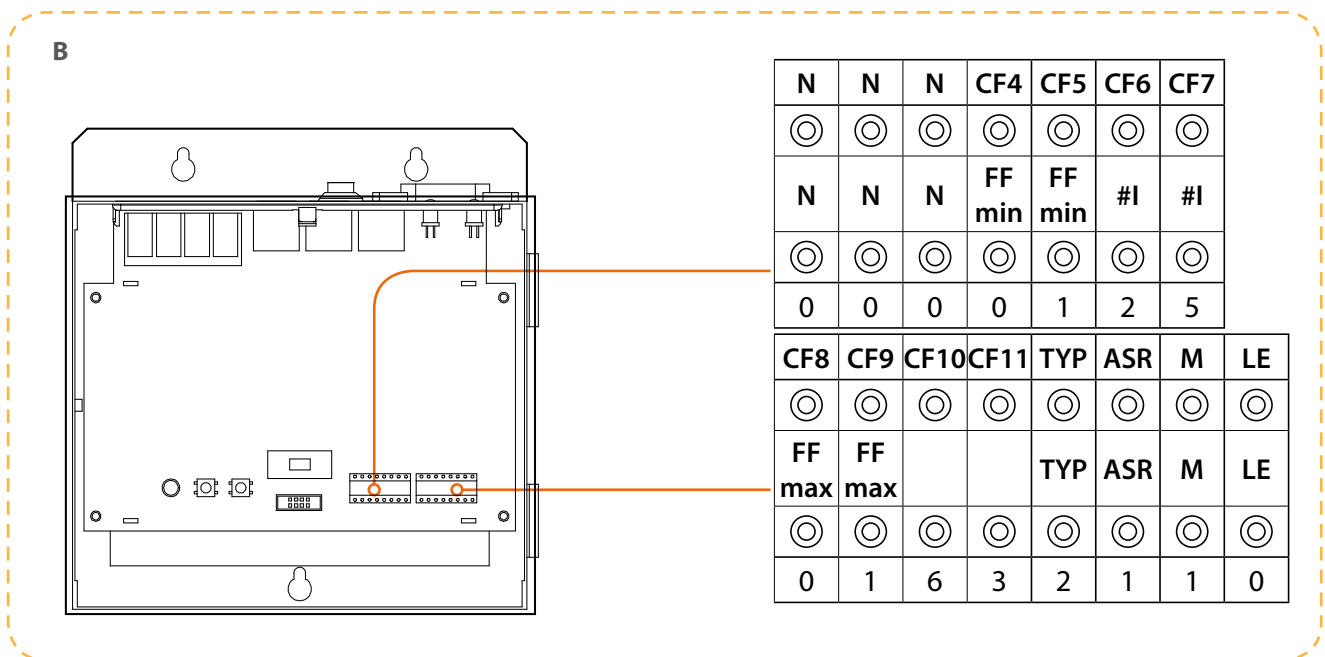
## Accessory configuration examples

### 323005 - POWER SUPPLY CONFIGURATION

Example (C):

If necessary enable the smart power function, no need for the power management function (if no management function, the power supply address does not need to be set), the range of handset addresses managed by the power supply is 125-163. Without alarm, it means that the current of alarm sensor is 0 mA. The system used mode 3 configuration. The power supply configuration should be as follows:

POSITION	MODE 1	VALUE FOR CONFIGURATOR	REMARKS
CF1	N	0	
CF2	N	0	
CF3	N	0	
CF4	FF Min	0	
CF5	FF Min	1	
CF6	#I	2	
CF7	#I	5	
CF8	FF Max	0	
CF9	FF Max	1	
CF10	CF10	6	
CF11	CF11	3	
CF12	Type	2	
CF13	ASR	1	
CF14	M	1	
CF15	LE	0	



### 323005 - POWER SUPPLY CONFIGURATION CHOOSING THE SYSTEM POWER SOLUTION

- Solution 1: PWS 323005 will be chosen as system power supply inside the riser while auxiliary PWS (323010) will be chosen for all the auxiliary power supply.
- Solution 2: PWS 323005 will be chosen for both system power supply inside the riser and auxiliary power supply.

*Note: when the system includes Small EP, solution 2 will be helpful to avoid possible damage to the power supply in the system. When the system has handsets connected to Small EP, sometimes if several Small EP call handsets at the same time, a power supply overload may occur. Under this situation there is a risk of damage to the power supply.*

Suggested power supply solution and related configuration:

NO.	SYSTEM		PWS SOLUTION	CONFIGURATION WHEN PWS IS SYSTEM POWER SUPPLY (IMPEDANCE SWITCH OF PWS MUST BE ON)						CONFIGURATION OF PWS AND AUXILIARY PWS WHEN PWS IS AUXILIARY POWER SUPPLY (IMPEDANCE SWITCH OF POWER SUPPLY MUST BE OFF)					
	ALARM	SMALL EP		CF1 ~ CF3 (NNN)	CF4 ~ CF11	CF12 (TYPE)	CF13 (ASR)	CF14 (M)	CF15 (LE)	CF1 ~ CF3 (NNN)	CF4 ~ CF11	CF12 (TYPE)	CF13 (ASR)	CF14 (M)	CF15 (LE)
1	No	No	1	X	X	X	X	X	X	Here use Auxiliary Power supply, configuration is not necessary.					
2	No	No	1	X	X	X	X	X	X						
3	Yes	No	1	X	X	X	X	X	X						
4	Yes	No	1	NNN	X	1	0.2-9	1	X						
5	No	Yes	2	NNN	√	1	1	0/1	X	X	√	2	1	0/1	X
6	No	Yes	2	NNN	√	1	1	0/1	X	X	√	2	1	0/1	X
7	Yes	Yes	2	NNN	√	1	0.2-9	0/1	X	X	√	2	0.2-9	0/1	X
8	Yes	Yes	2	NNN	√	1	0.2-9	0/1	X	X	√	2	0.2-9	0/1	X

**Note:**

*X: It means no configurator is needed and the configuration position is 0; others need a configurator with corresponding value.√: It means configuration is needed. For the configuration procedure refer to the system configuration chapter.*

## Accessory configuration examples

### 323013 - DISTRICT GENERATOR CONFIGURATION

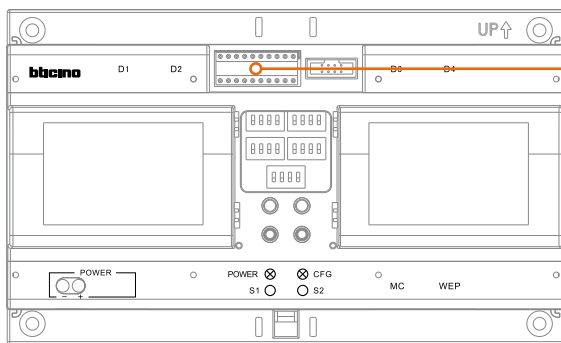
#### POSSIBLE CONFIGURATION PROCEDURES FOR DISTRICT GENERATOR

	MODE 1
Resistor configuration	√
Keyboard configuration	√
RS232 configuration	√

#### MEANING OF EACH CONFIGURATOR SOCKET PIN

POSITION	MODE 1	
CF1	EPS	If 323013 is primary. EPS must be set as Max WEP address on WEP port
CF2		If 323013 is secondary. EPS must be set as Max WEP address on MC port
CF3	MC	Set Switchboard address range
CF4	Min	
CF5		
CF6	MC Max	
CF7	P/S	0: primary 323013 1: secondary 323013

#### CONFIGURATORS POSITION FOR DISTRICT GENERATOR

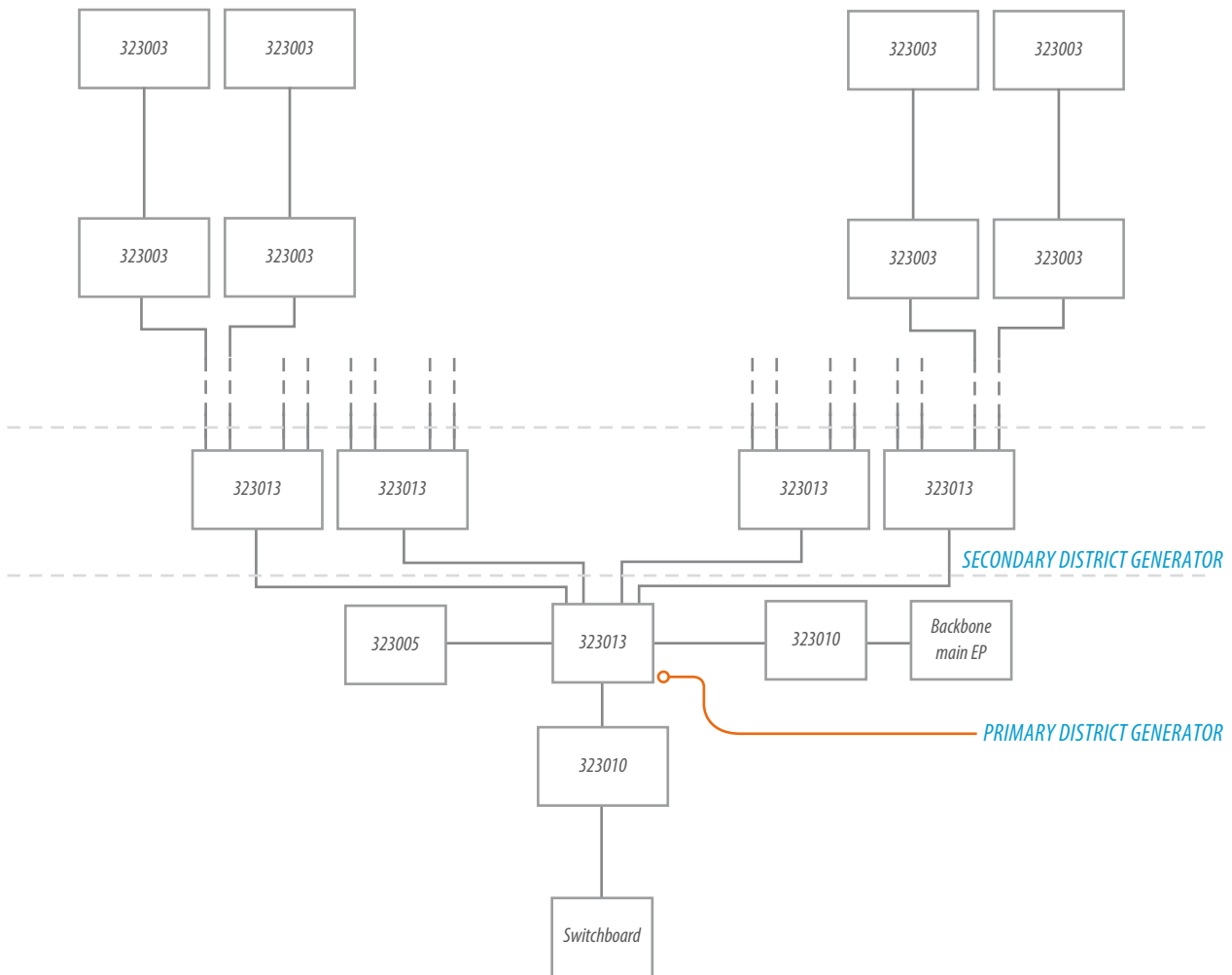


EPS	EPS	MC Min	MC Min	MC Max	MC Max	P/S	CF8	CF9	CF10
⊙	⊙	⊙	⊙	⊙	⊙	⊙	⊙	⊙	⊙
EPS	EPS	MIN	MIN	MAX	MAX	P/S			
⊙	⊙	⊙	⊙	⊙	⊙	⊙	⊙	⊙	⊙

**323013 - DISTRICT GENERATOR CONFIGURATION**

When there are two District generator layers in the system, no main EP can be installed on the main EP port of the second DG layer. It must be made sure that:

main EP number on main EP port of first DG layer < main EP number in first DG layer branch < main EP number in second DG layer branch.

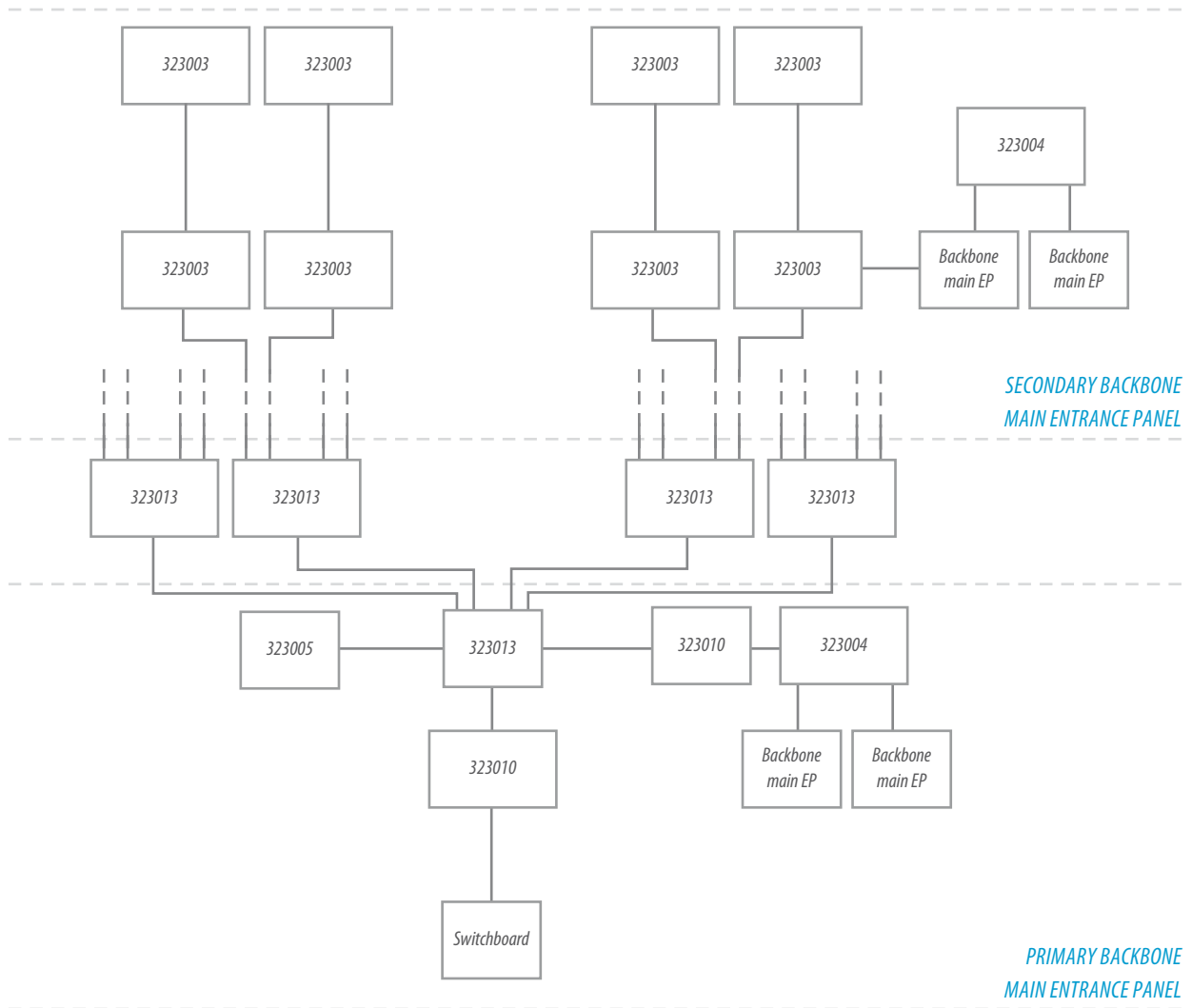


## Accessory configuration examples

### 323013 - DISTRICT GENERATOR CONFIGURATION

If 323013 is primary, EP must be set as Max WEP address on WEP port

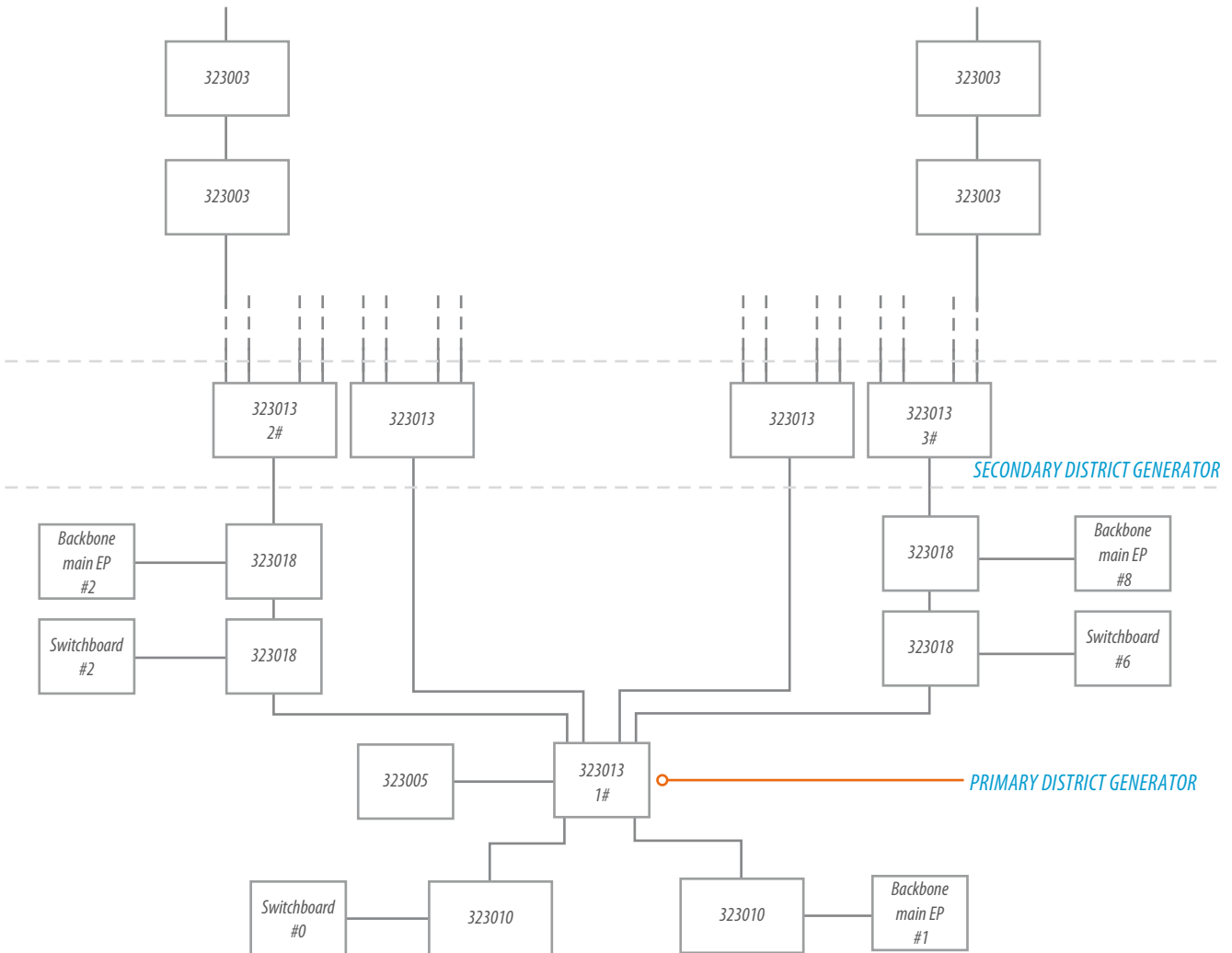
If 323013 is secondary. EP must be set as Max WEP address on MC port



### 323013 - DISTRICT GENERATOR

Example (A):

Use 323018 to extend the first District Generator and the second District Generator layer MC port to install the main EP and the Switchboard. Below diagram 1~3# District generator configuration example:



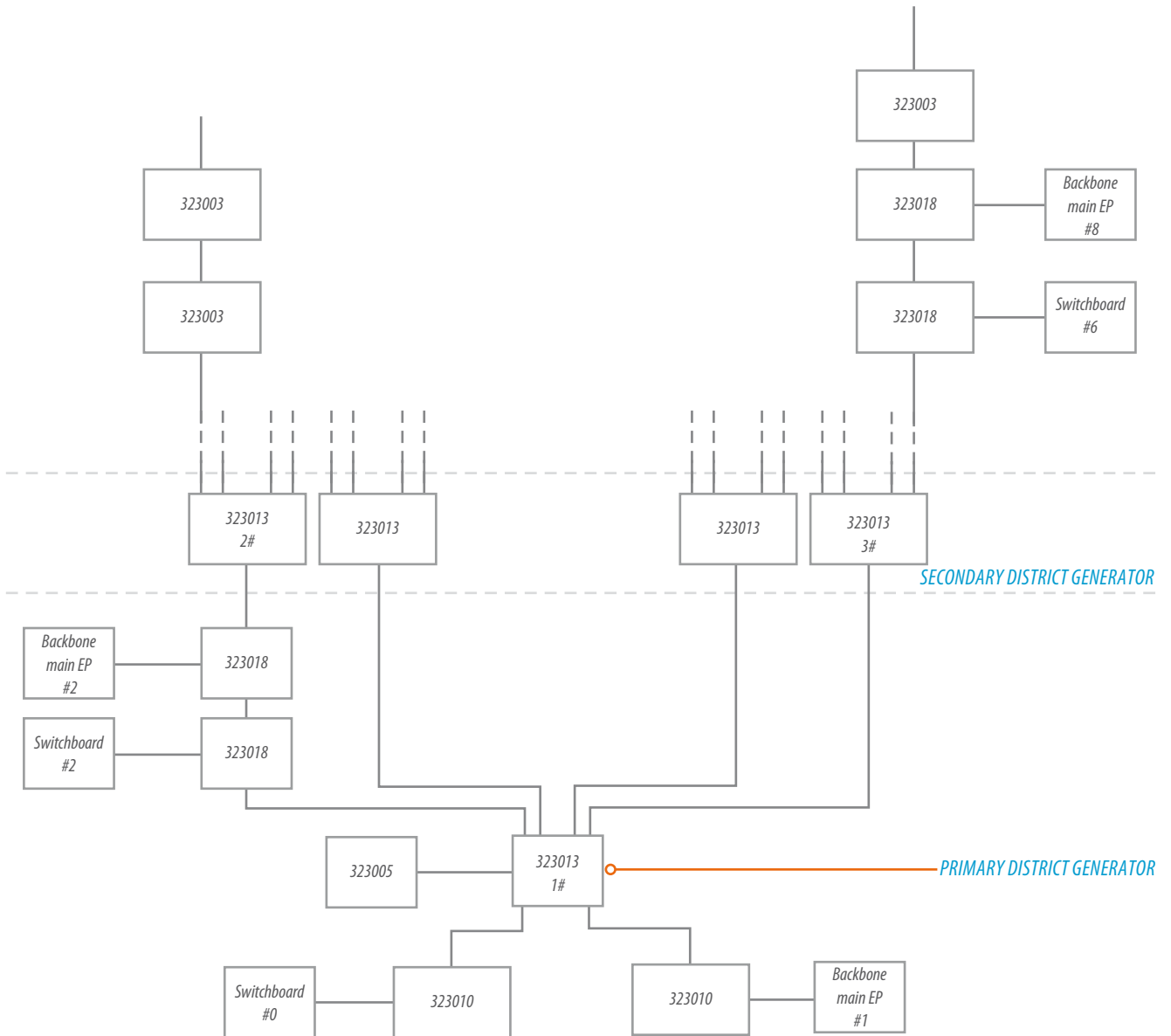
Position	Field Name	1# DISTRICT GENERATOR	2# DISTRICT GENERATOR	3# DISTRICT GENERATOR	Remarks
CF1	EPS	0	0	0	NULL means 0
CF2		1	2	8	
CF3	MC Min	0	0	0	
CF4		0	0	0	
CF5		0	0	0	
CF6	MC Max	0	0	0	
CF7	P/S	0	1	1	

## Accessory configuration examples

### 323013 - DISTRICT GENERATOR

Example (B):

Use the EP/Switchboard shunt to extend some second District generator layer MC port and first District generator layer branch to install the main EP and Switchboard. Some second District generator layer branch could be extended to install the main EP and Switchboard also using the EP/Switchboard shunt. Below diagram 1~3#District generator configuration example:

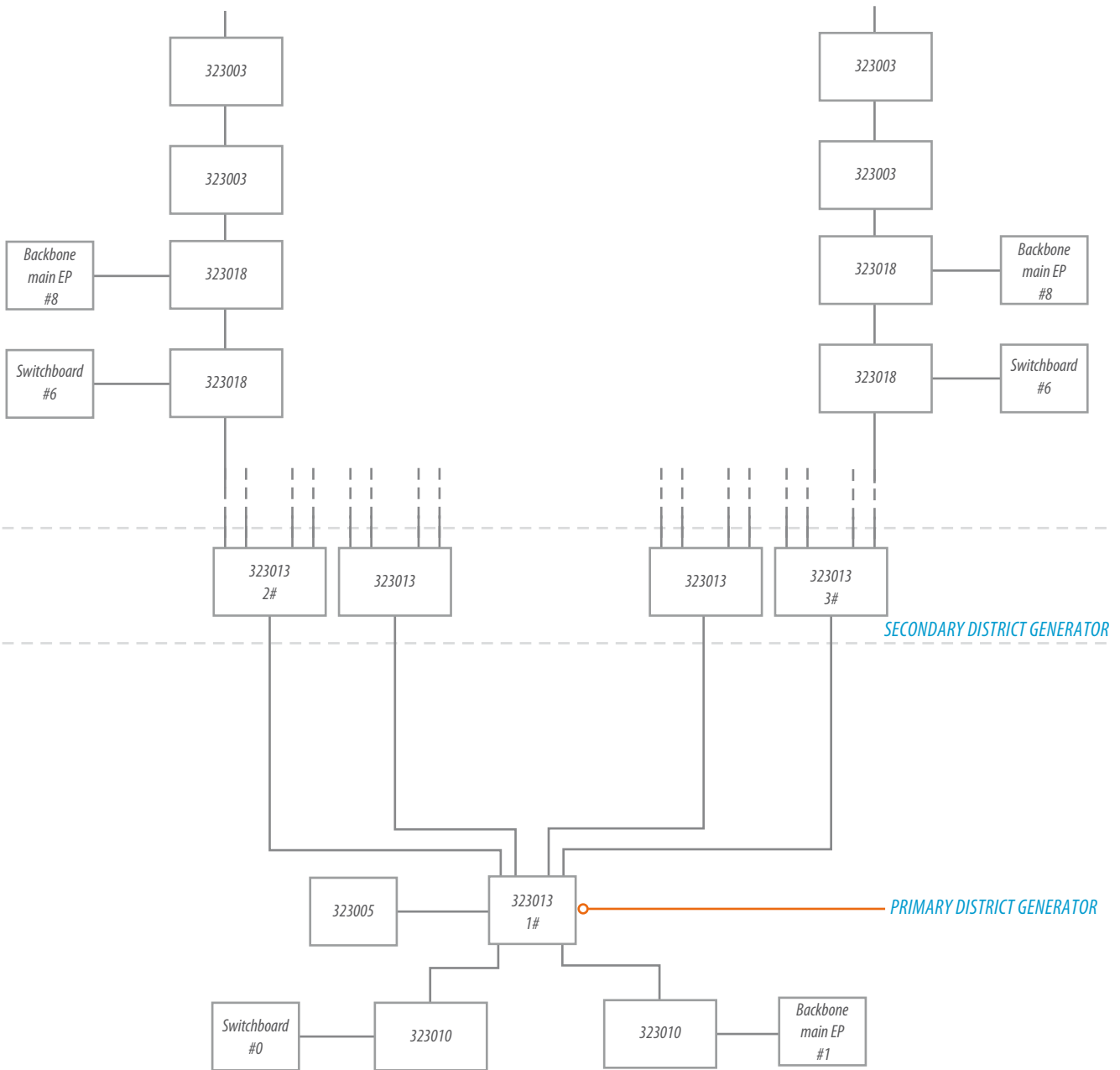


Position	Field Name	1# DISTRICT GENERATOR	2# DISTRICT GENERATOR	3# DISTRICT GENERATOR	Remarks
CF1	EPS	0	0	0	NULL means 0
CF2		1	2	1	
CF3	MC Min	0	0	0	
CF4		0	0	6	
CF5	MC Max	0	0	0	
CF6		0	0	6	
CF7	P/S	0	1	1	

**323013 - DISTRICT GENERATOR**

Example (c):

Use the EP/Switchboard shunt to extend the branch of the second DH1 layer to install WEP and Switchboard. Below diagram 1~3# DH1 configuration as an example:



Position	Field Name	1# DISTRICT GENERATOR	2# DISTRICT GENERATOR	3# DISTRICT GENERATOR	Remark
CF1	EPS	0	0	0	NULL means 0
CF2		1	1	1	
CF3	MC Min	0	0	0	
CF4		0	2	6	
CF5	MC Max	0	0	0	
CF6		0	2	6	
CF7	P/S	0	1	1	

## Troubleshooting

1. ***The indicators flash when the handset is called, but there is no ring.***  
When the handset being called does not ring check if it is in silent mode. If yes, please switch it over to standard common mode.
2. ***The indoor unit is unable to monitor the entrance panel.***  
Check whether the first entrance panel in the riser has been set as the no 1 entrance panel, and make sure that the numbers of the entrance panels in the riser are in sequence without repetitions.
3. ***Unable to monitor the Small EP.***  
The function for monitoring the small EP can be only used after installation personnel has set the system depending on the actual requirements. If the unit has been set as a door bell, then the function for monitoring the gate EP will be disabled automatically.
4. ***Double click to turn Small EP monitoring on.***  
When starting the small EP monitor function make sure that the double click interval is kept within 800 ms (namely quick double click on the monitor key), or it will be considered a request to monitor the EP.
5. ***How to make sure that the riser installation is correct.***  
Once installing a handset, first set its number as 101 (default ex-factory value). The entrance panel will now call handset 101. If the call gets through correctly, the normal video image will appear, confirming that the hardware installation and line connection are correct (on adjusting other handset, first disconnect the first handset at the 1st floor to avoid having two handsets with the same address). In case of more problems, please check the configuration of other related devices. Once the settings have been confirmed, it is possible to set the handset with its actual number.
6. ***When the entry panel calls a handset with a certain number, the handset answers but there is no voice or video signal.***  
If the entrance panel can call all handsets with a number smaller than a certain number (e.g. all handset with number lower than 501 can be called), these handset will answer normally. However if a call is made to a handset with that number or a higher number, there is no sound on answering and no video image is displayed. Now confirm whether the configuration on the riser shunt is correct. Take out the riser shunt from the unit system and directly connect the EP to the floor shunt to check if it works correctly. If it does it means that the riser shunt is set incorrectly.
7. ***The entrance panel fails to call a certain handset.***  
The handset number may be set incorrectly, in which case reset the number and try again. If the call still fails, set the number as 101 and try again. If it is successful it may be that the handset household on each floor is not the same as the #II setting on the entrance panel. Reset this again. If the call still fails, it may be due to the line or other devices. Replace the handset and check the line. The handset will not answer calls while in installation setup status. Exit installation setup status and try again.
8. ***The entrance panel can call the handset normally without any problems.***  
*However, the internal indoor units can't be called through and when answered, they can't have a talk.*  
Please make sure that the set parameters of two indoor units are identical. If unable to ensure that, please restore the default parameters and reset.
9. ***The Small EP can't have a conversation with the handset and there is no video signal***  
Please disable the doorbell function (this function is disabled by default). When the doorbell function is enabled, and the small EP or the doorbell calls in, the system will ring but no conversation will be possible. This is normal and ringing will automatically stop after 10 seconds.
10. ***On connecting the Apartment interface, the handset's own number won't be the same as the one previously set.***  
On connecting an apartment interface, the handset will automatically detect the connection and change its own number to 101. The handset will automatically use the number set by the apartment interface.
11. ***On being powered, the handset will send the SOS to the Switchboard.***  
SOS switch type is different from the setting type. Default setting SOS type is NO (Normally Open).
12. ***The alarm handset cannot be armed.***  
If the alarm handset cannot be armed, it may be due to the following:
  - the probe type is incorrectly set. For example, the normally closed type is set as normally open;
  - the probe is not connected or not correctly set. First ensure that the probe is correctly connected to hardware, and then open software setup to enable it. There is an overcurrent on the alarm probe and it cannot be guarded until repowered after 10 seconds.
13. ***The handset is unable to start the Small EP monitoring function.***
  - IU be set as Slave  
Only the master handset can monitor the Small EP.
  - IU enable door bell function  
If the handset starts the doorbell function, it will automatically close down the small EP.

14. ***The handset is unable to set the household number***

When the handset is connected with an Apartment interface, the household number cannot be set. When the last two digits of the household number are higher than the number of users (#I) on each floor, the household number cannot be set. For example, if the handset is programmed for one-riser two-households on each floor, then it will be illegal to set the household number as 203.

15. ***Some parameters cannot be set.***

Some parameter settings in the handset rely on other parameter settings, namely they have an interlocking relation. If the doorbell function is enabled, Small EP monitoring cannot start. When unclear about which parameter is incorrect, it is recommended to reset the default parameters and start again.

*Note: after the default parameter has been restored, all the other parameters will be restored to the ex-factory value.*

16. ***The alarm indicators or the zone indicators are always on irrespective of the status:***

This results from the overcurrent of the alarm probe powered by the handset which automatically causes a protection status. Disconnect the power after 10 seconds to eliminate the fault.

17. ***When the Small EP calls in, the handset returns to the idle mode immediately:***

This is the result of a short-circuit on the Small EP. Please eliminate the problem and then reconnect.

18. ***The secondary EP can call the handset normally, but when the main EP calls the handset, conversation is possible but there is no video signal.***

Make sure that main EP is connected to system out port of riser shunt.

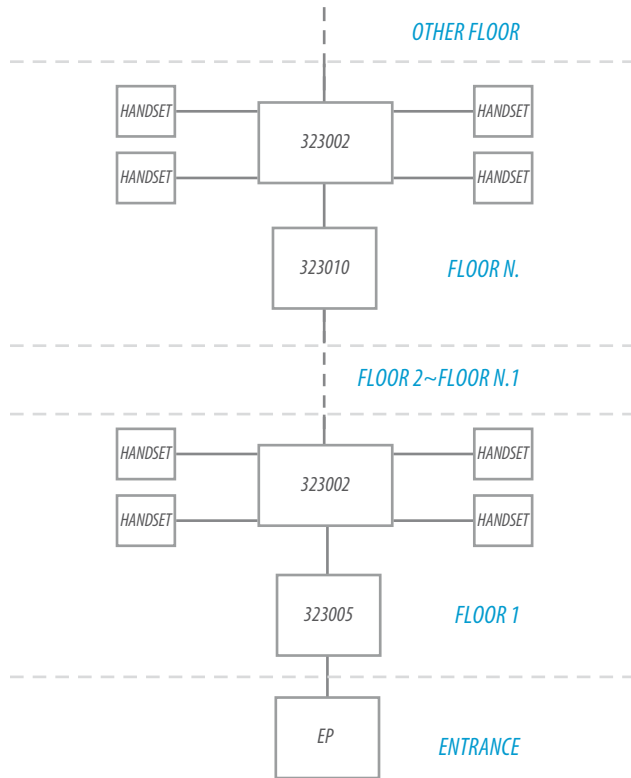


**INDEX****SYSTEM TOPOLOGY - LAYOUT EXAMPLES**

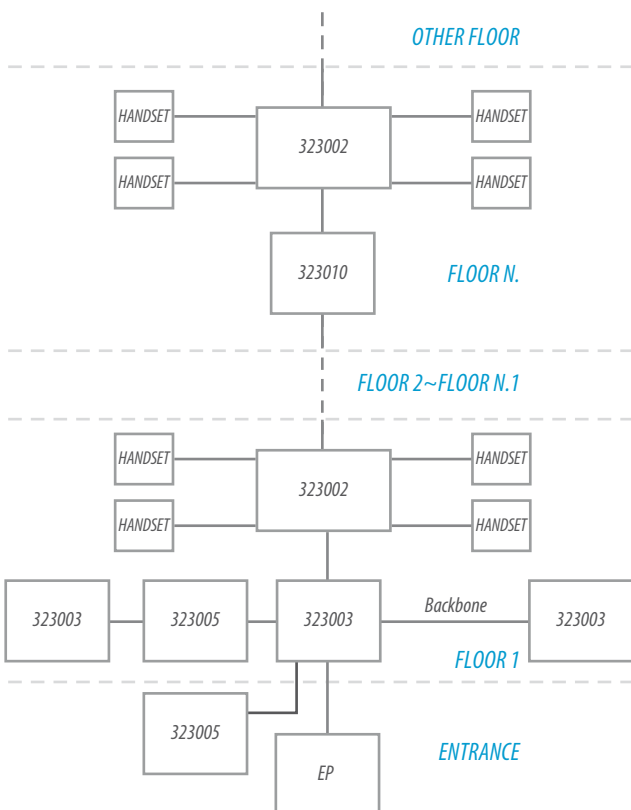
1/2 - Riser network without switchboard . . . . .	128
3 - Backbone with only one main entrance panel . . . . .	128
4 - Backbone with only one switchboard . . . . .	128
5 - Backbone with district generator . . . . .	129
6 - Riser with mixed installation . . . . .	130
7 - Internal unit connection. . . . .	131
8 - Connection between audio and video handset . . . . .	131
9 - BTicino 2 wire interface connection . . . . .	131
10/11 - Basic apartment interface. . . . .	131
12 - Riser with several EPs without riser shunt . . . . .	132
13/14 - Backbone with several main EPs. . . . .	132
15 - Riser with more than 5 EPs . . . . .	134
16 - 2 branches video splitter connection. . . . .	135
17 - Riser with system expansion interface . . . . .	137

# System layout examples

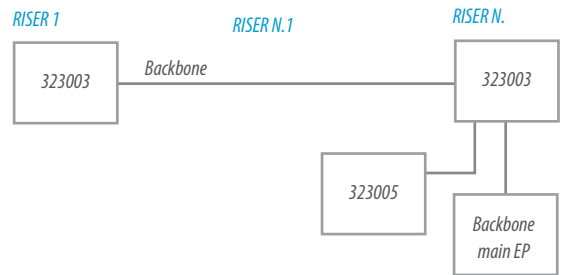
**EXAMPLE 1**  
RISER NETWORK WITHOUT SWITCHBOARD



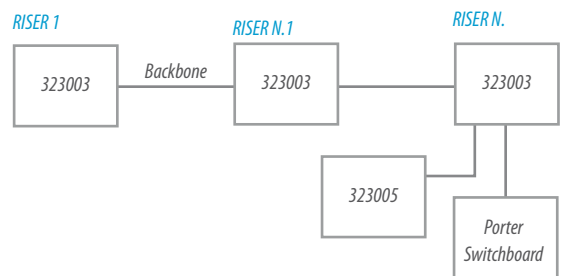
**EXAMPLE 2**  
RISER NETWORK WITHOUT SWITCHBOARD



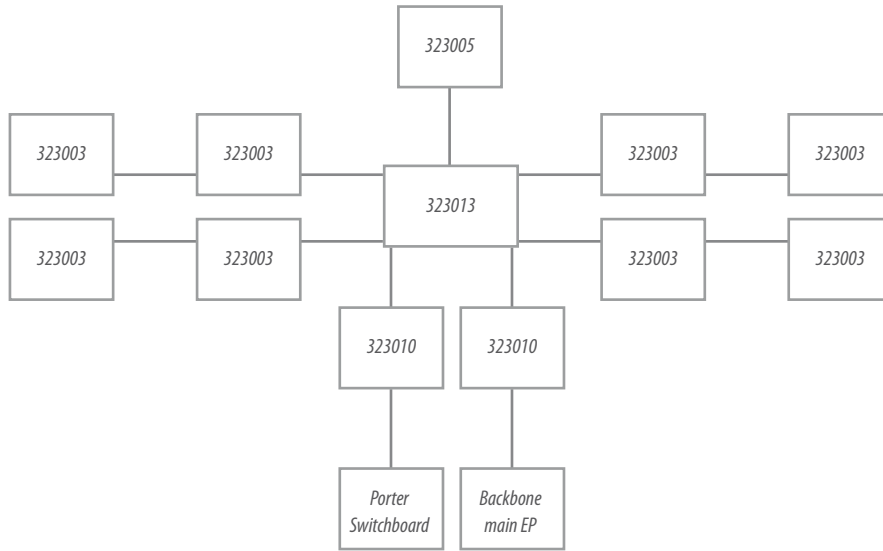
**EXAMPLE 3**  
BACKBONE WITH ONLY ONE MAIN EP



**EXAMPLE 4**  
BACKBONE WITH ONLY ONE SWITCHBOARD



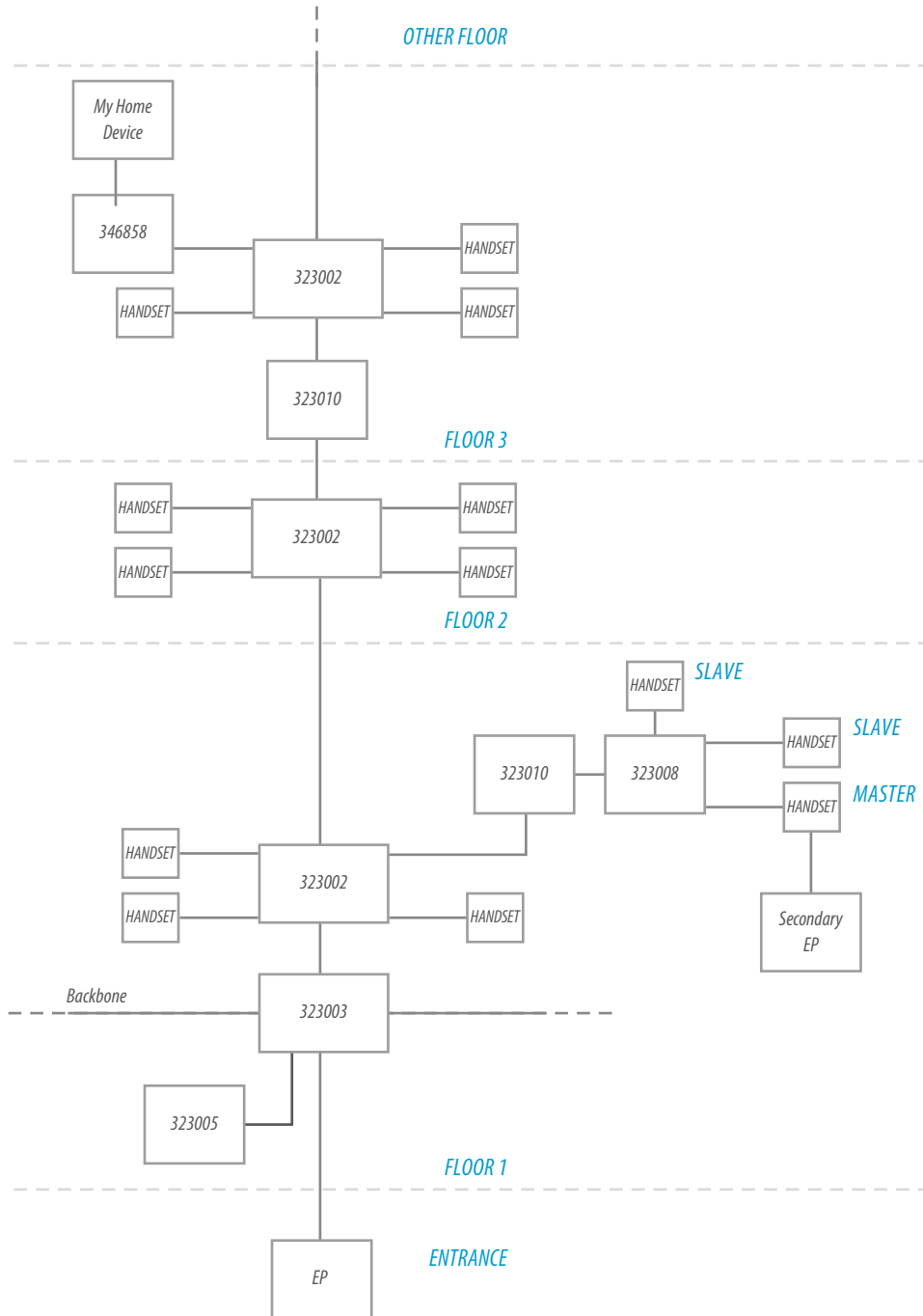
**EXAMPLE 5**  
**BACKBONE WITH DISTRICT GENERATOR**



# System layout examples

## EXAMPLE 6

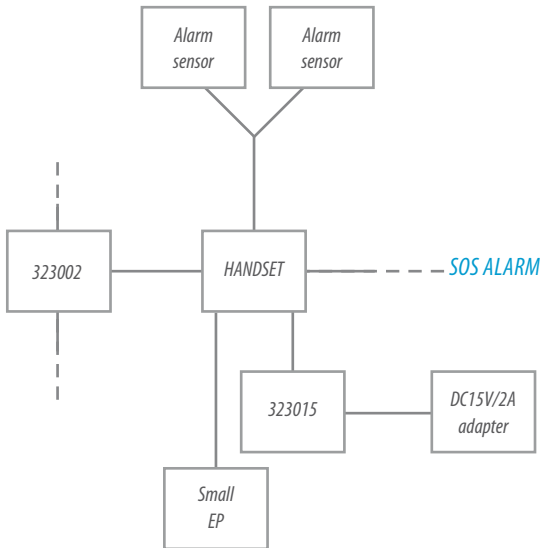
### RISER WITH MIXED INSTALLATION



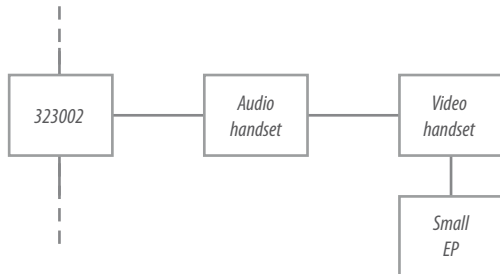
*This diagram only shows the possible riser installation*

Function available : It is depended on the backbone system and final products.

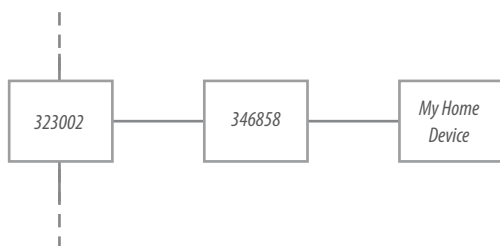
**EXAMPLE 7  
INTERNAL UNIT CONNECTIONS**



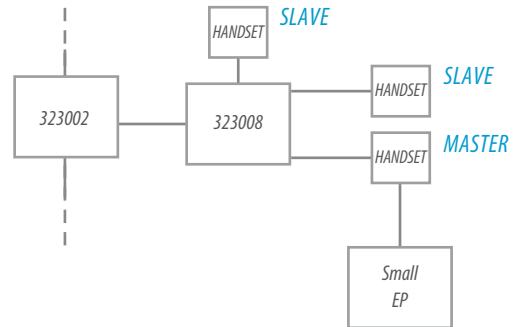
**EXAMPLE 8  
CONNECTION BETWEEN AUDIO HANDSET AND VIDEO HANDSET**



**EXAMPLE 9  
BTICINO 2 WIRE INTERFACE CONNECTION**

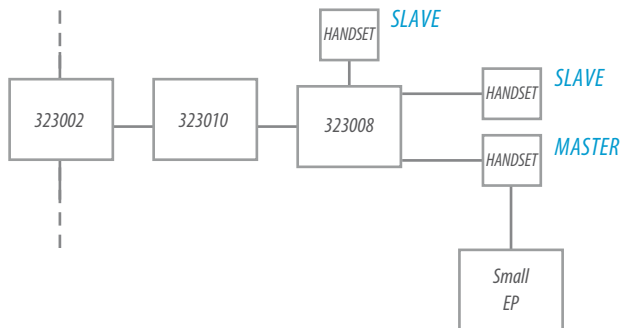


**EXAMPLE 10 AND 11  
BASIC APARTMENT INTERFACE CONNECTION**



Remark:

- The Small EP only can call the master handset, for conversation and door lock release.
- All handsets will ring, and the display of the master handset will come on. After the call is answered, the display on the handset answering the call will come on and the other handsets will stop ringing.
- The master handset can monitor the Small EP



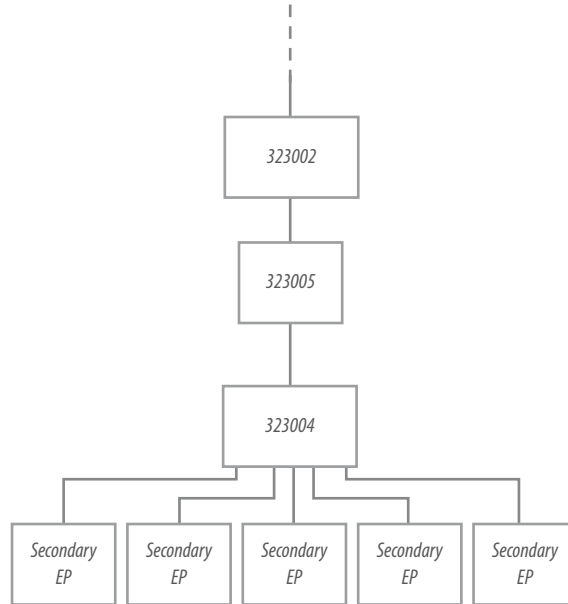
Remarks:

- When the total power consumption for all handsets connected to 323008 exceeds the limit, an auxiliary power supply (323010) is required.

## System layout examples

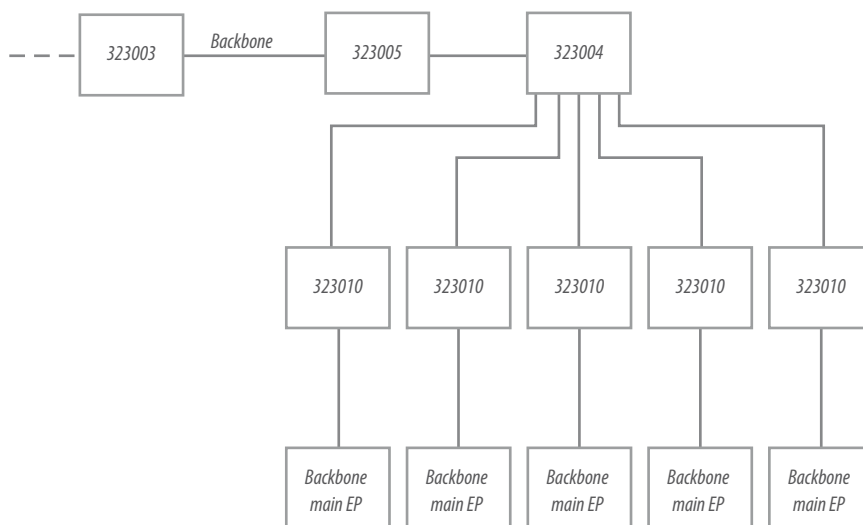
### EXAMPLE 12

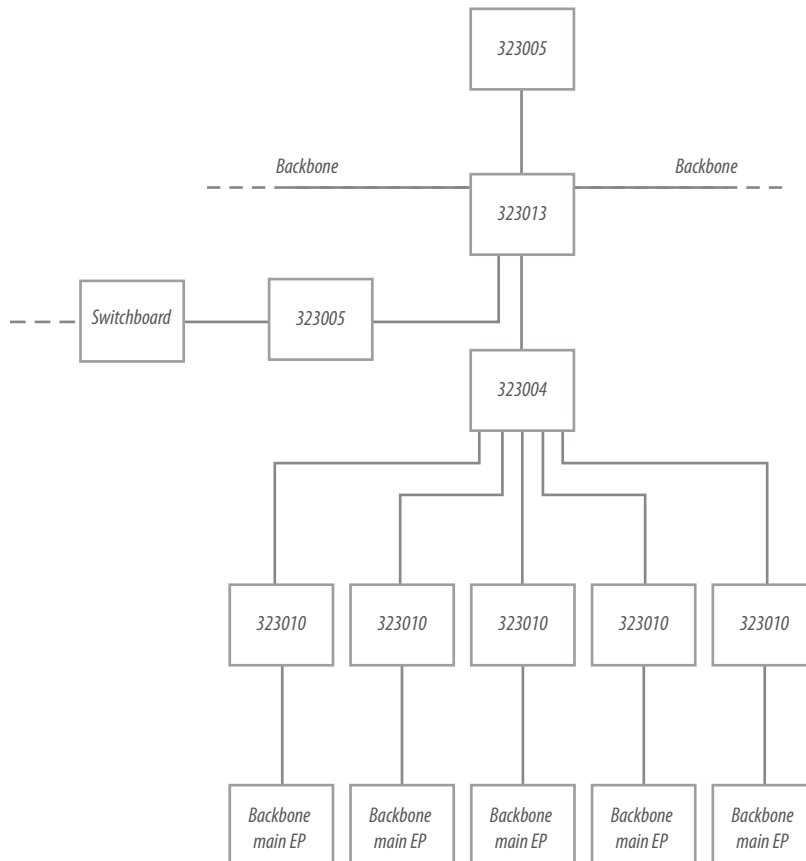
#### RISER WITH SEVERAL EP WITHOUT RISER SHUNT



### EXAMPLE 13

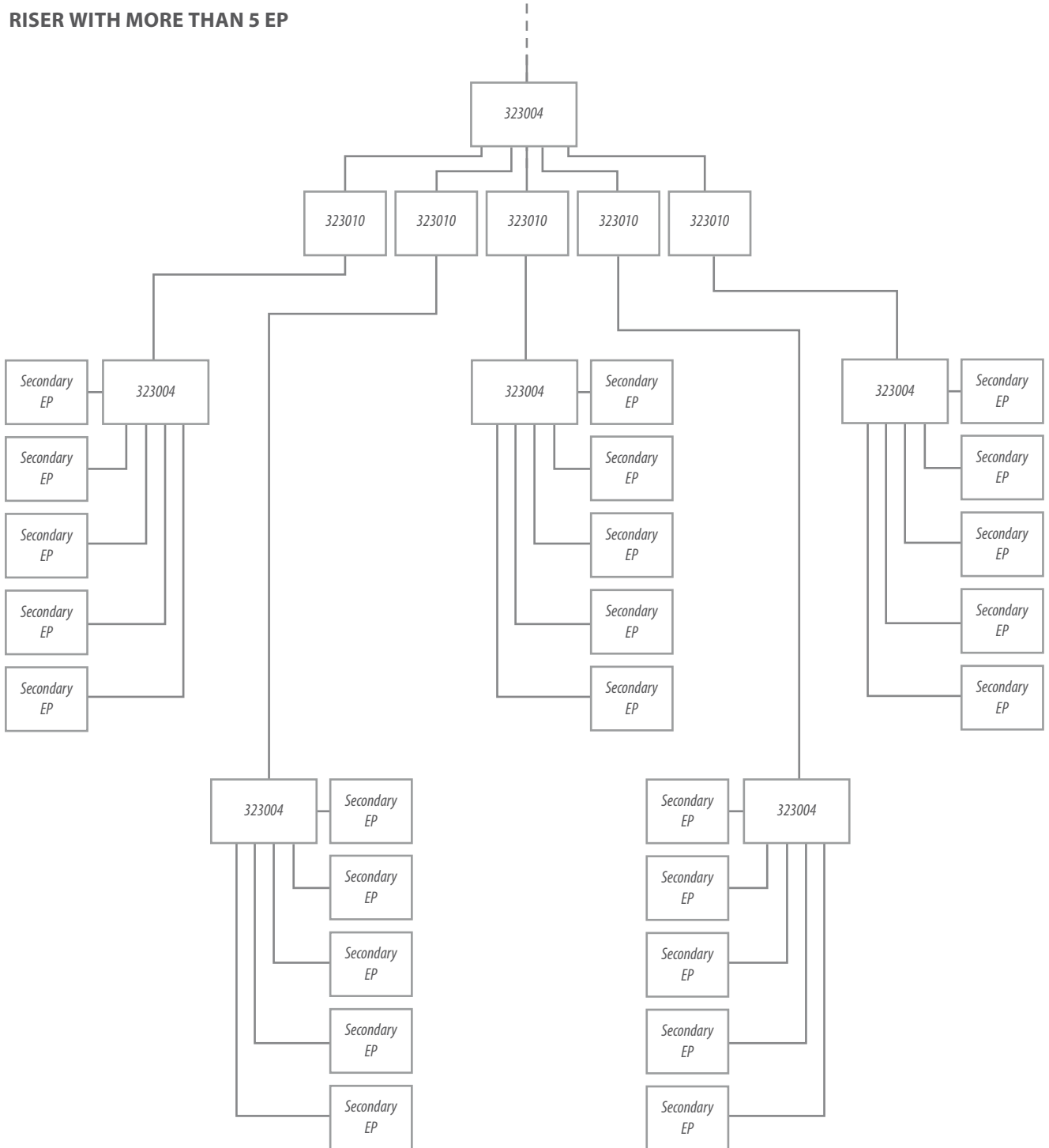
#### BACKBONE WITH SEVERAL MAIN EPS



**EXAMPLE 14****BACKBONE WITH SEVERAL MAIN EPS**

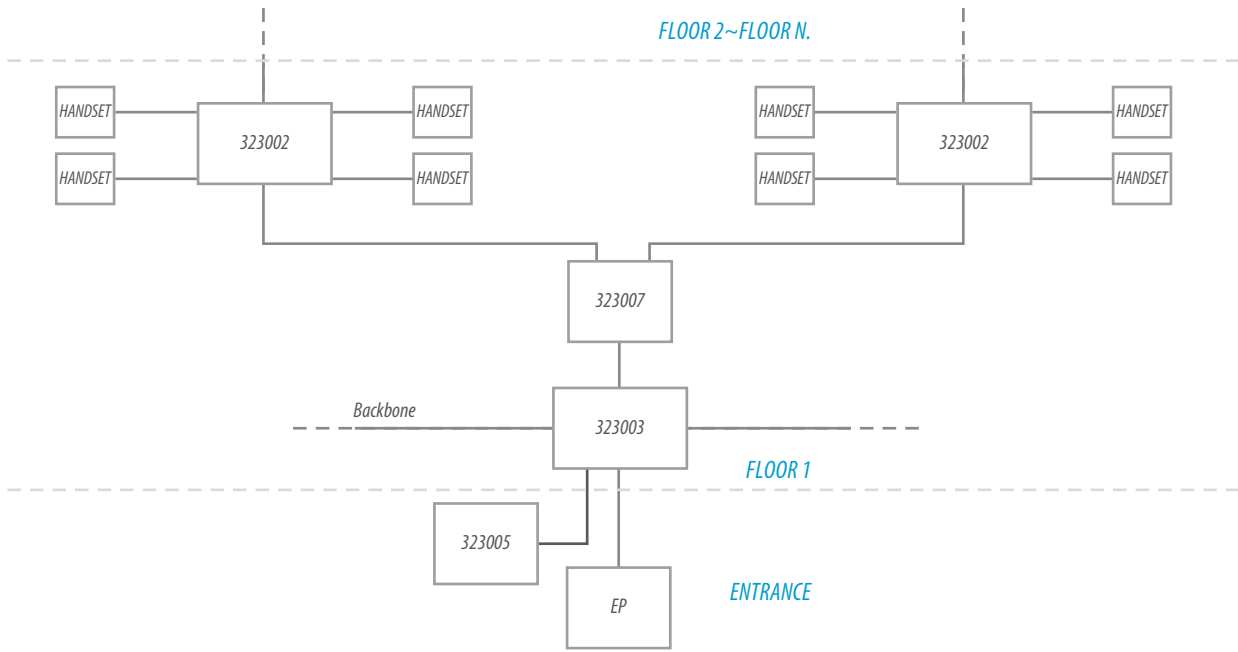
# System layout examples

**EXAMPLE 15**  
**RISER WITH MORE THAN 5 EP**



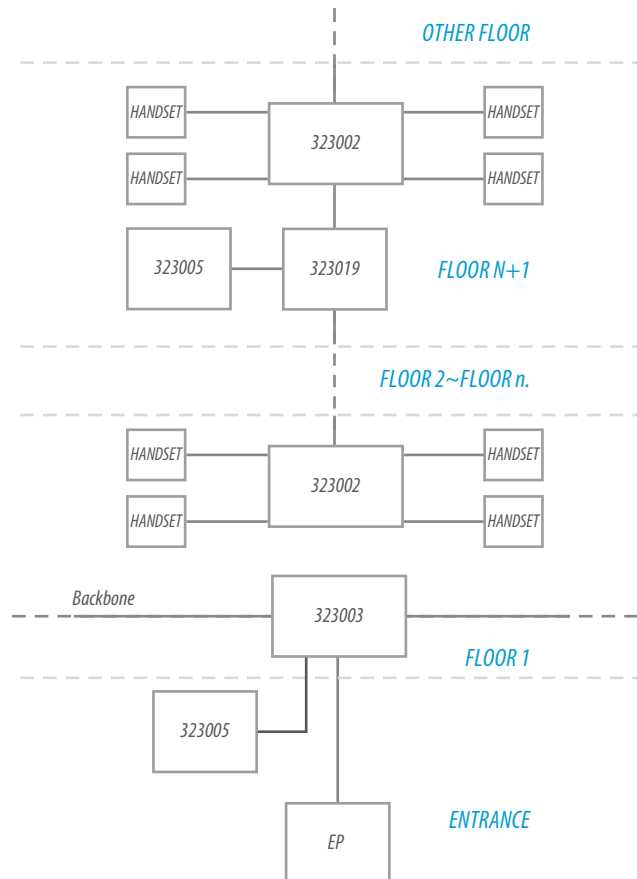
**EXAMPLE 16**

**2 BRANCHES VIDEO SPLITTER (323007)**



**EXAMPLE 17**

**RISER WITH EXPANSION INTERFACE (323019) TO EXTEND THE NUMBER OF HANDSETS**



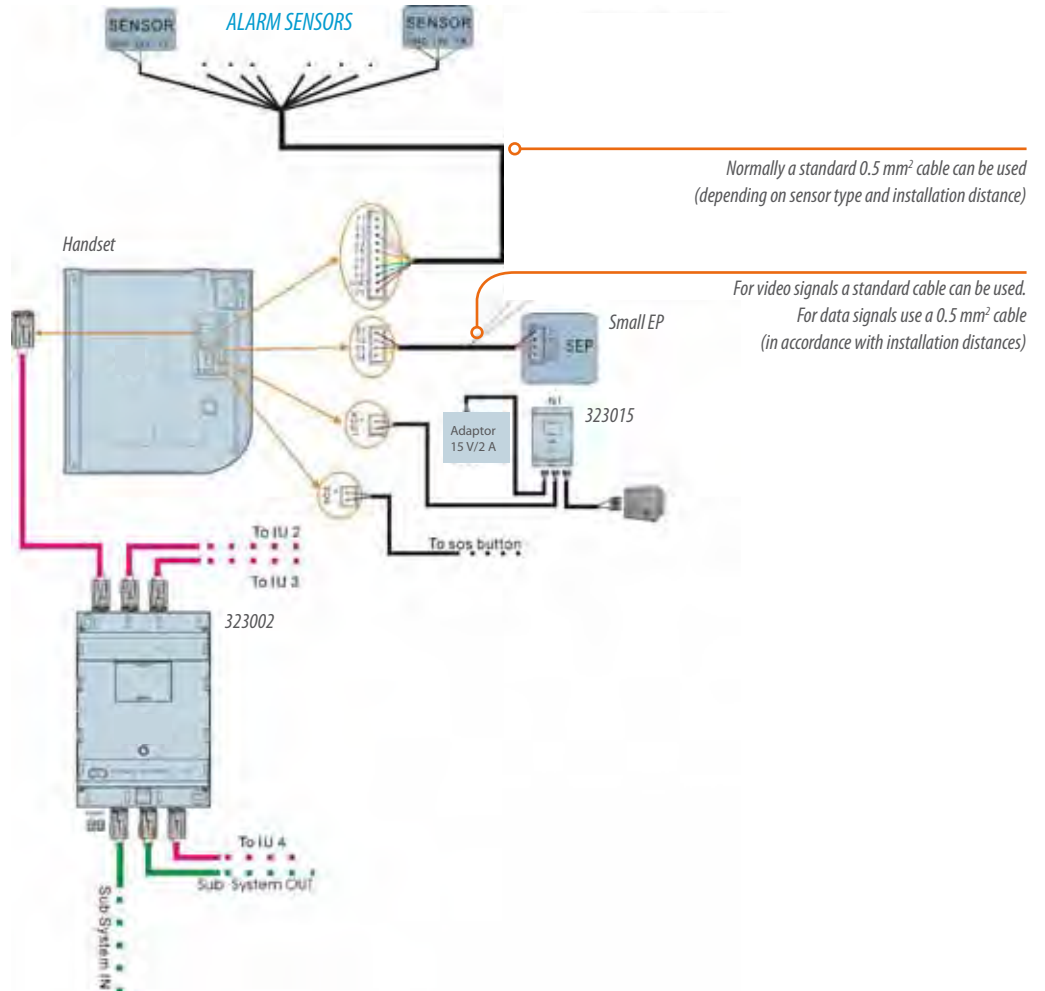


**INDEX****WIRING DIAGRAMS**

1 - Handset basic connection . . . . .	138
2 - Basic apartment interface connection . . . . .	139
3 - Riser connections with floor shunt . . . . .	140
4 - Riser connections with several EPs (1) . . . . .	141
5 - Riser connections with several EPs (2) . . . . .	142
6 - Backbone connection with 1 main EP . . . . .	143
7 - Backbone connection with 1 switchboard . . . . .	144
8 - Backbone connection with several EPs . . . . .	145
9 - District generator connection . . . . .	146
10 - 2 layer DG connection . . . . .	147
11 - 2 layer DG with several EPs . . . . .	148
12 - Riser with video mixer . . . . .	149
13 - Riser with 2 branches video splitter . . . . .	150
14 - Riser with expansion interface . . . . .	151
15 - Internal unit alarm sensors connection . . . . .	152

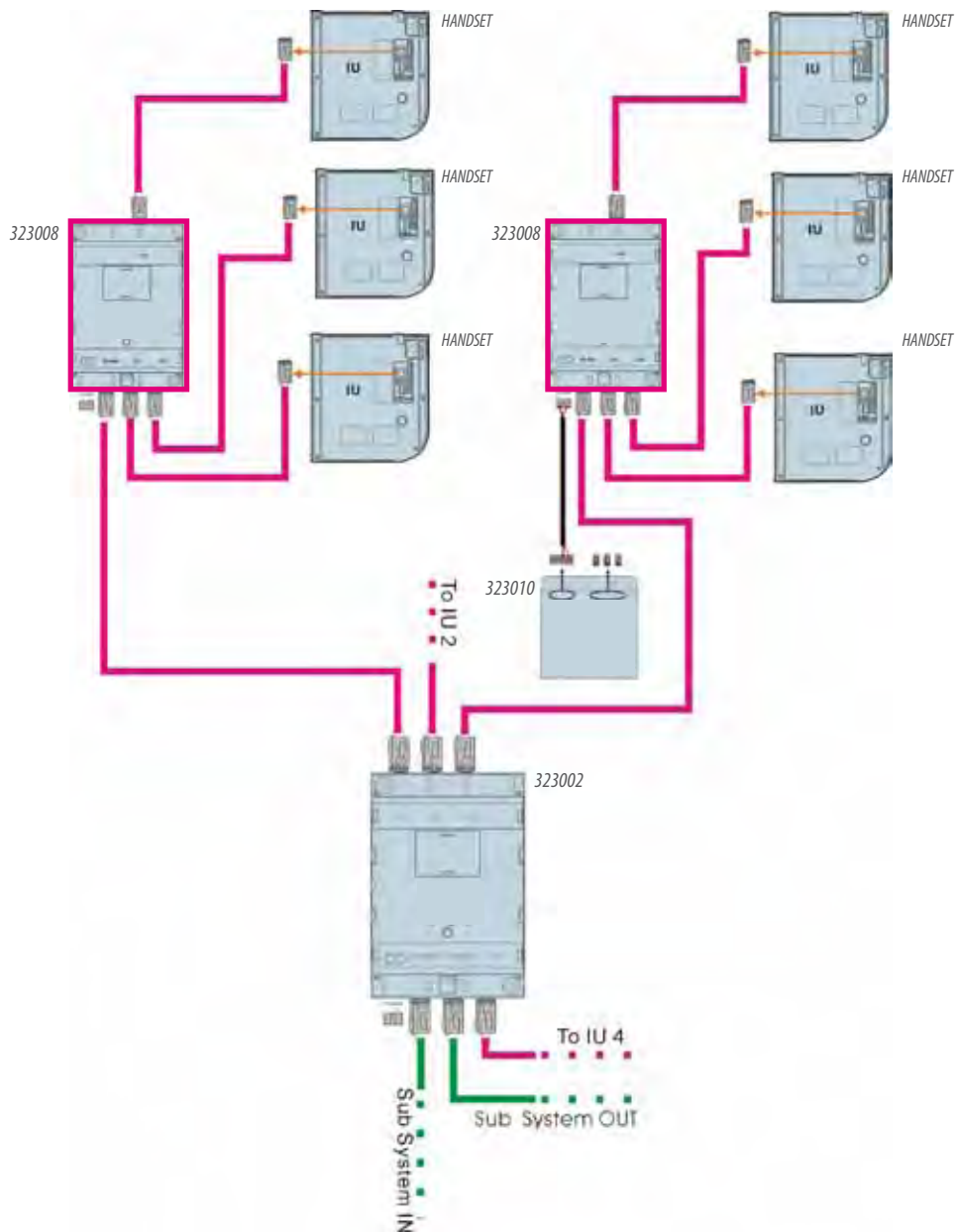
# Wiring diagrams

DIAGRAM 1  
HANDSET BASIC CONNECTIONS



**DIAGRAM 2**

**323008 - BASIC APARTMENT INTERFACE CONNECTION**



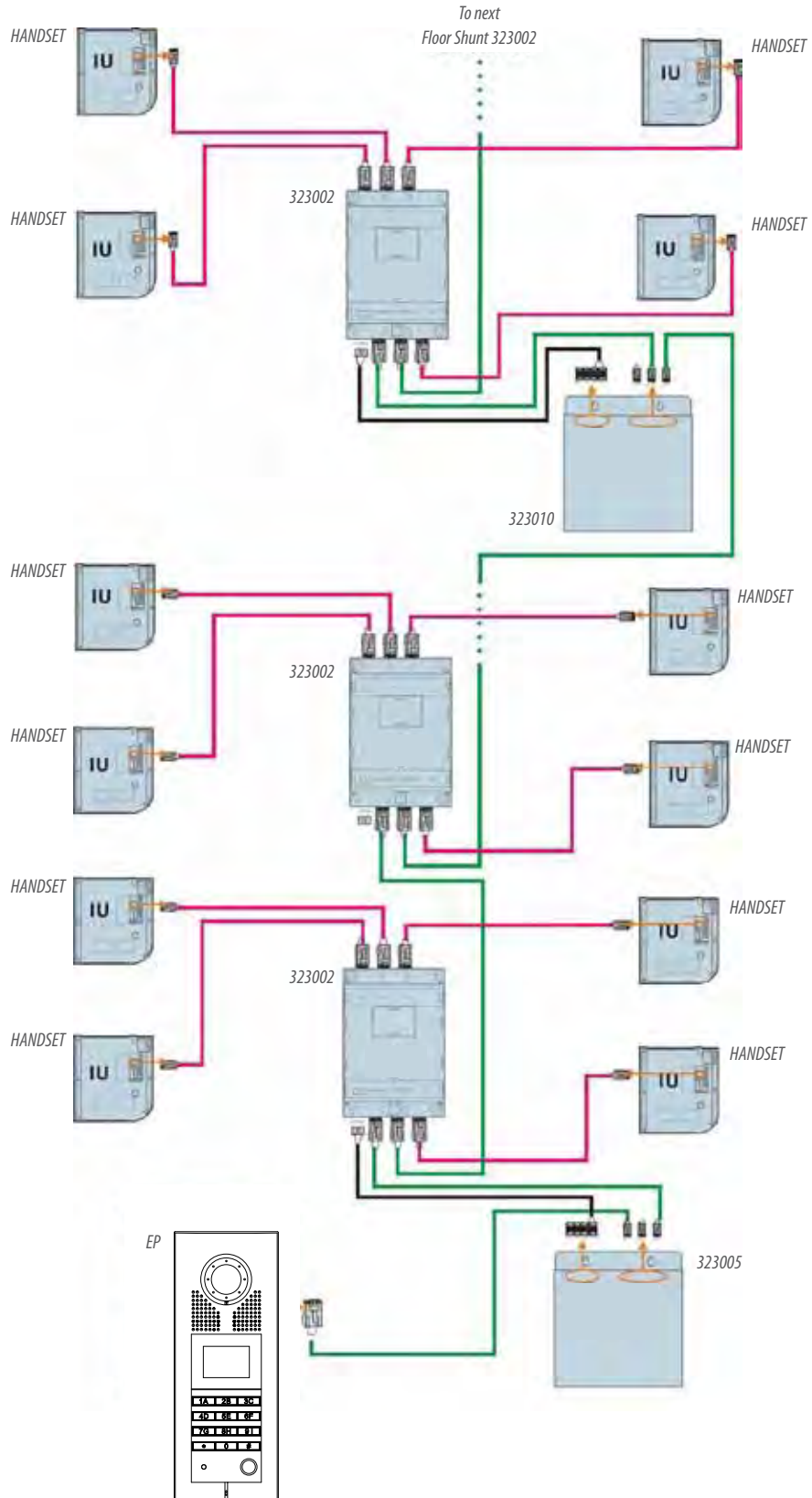
Remarks:

- When the total power consumption for all handsets connected to 323008 exceeds the limit, an auxiliary power supply (323010) is required.

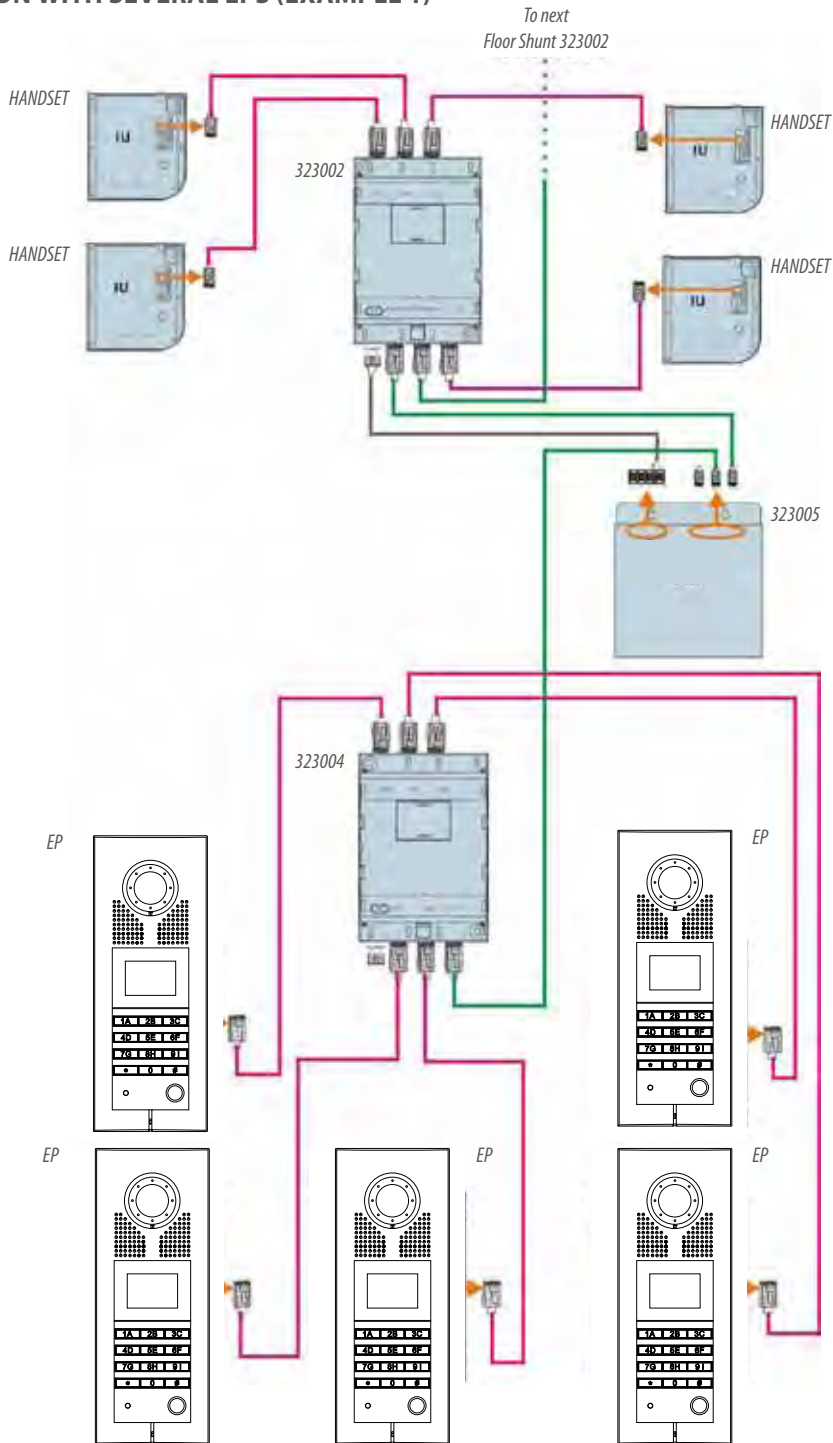
# Wiring diagrams

## DIAGRAM 3

### RISER HANDSETS CONNECTION WITH FLOOR SHUNT - 323002

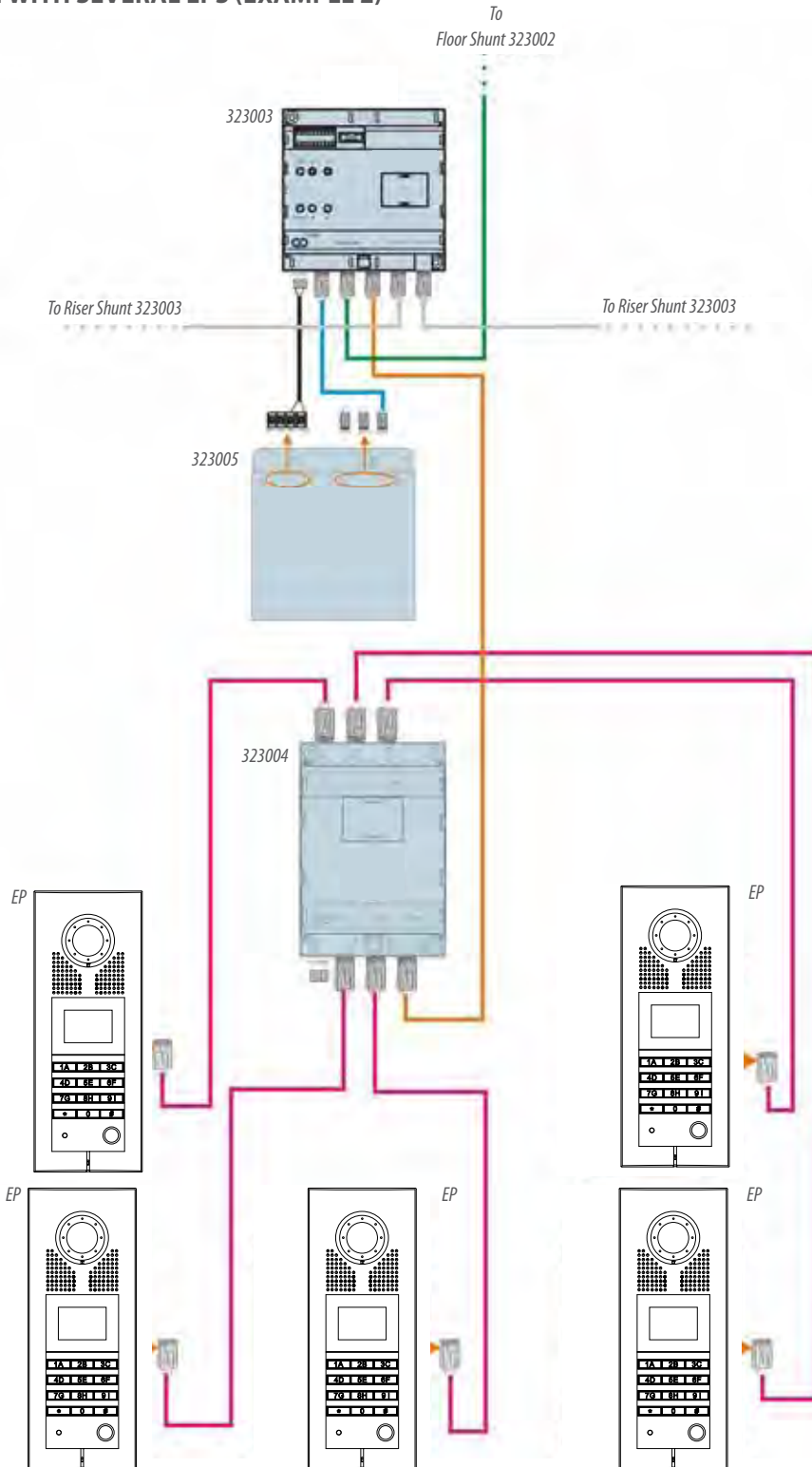


**DIAGRAM 4**  
**RISER CONNECTION WITH SEVERAL EPS (EXAMPLE 1)**

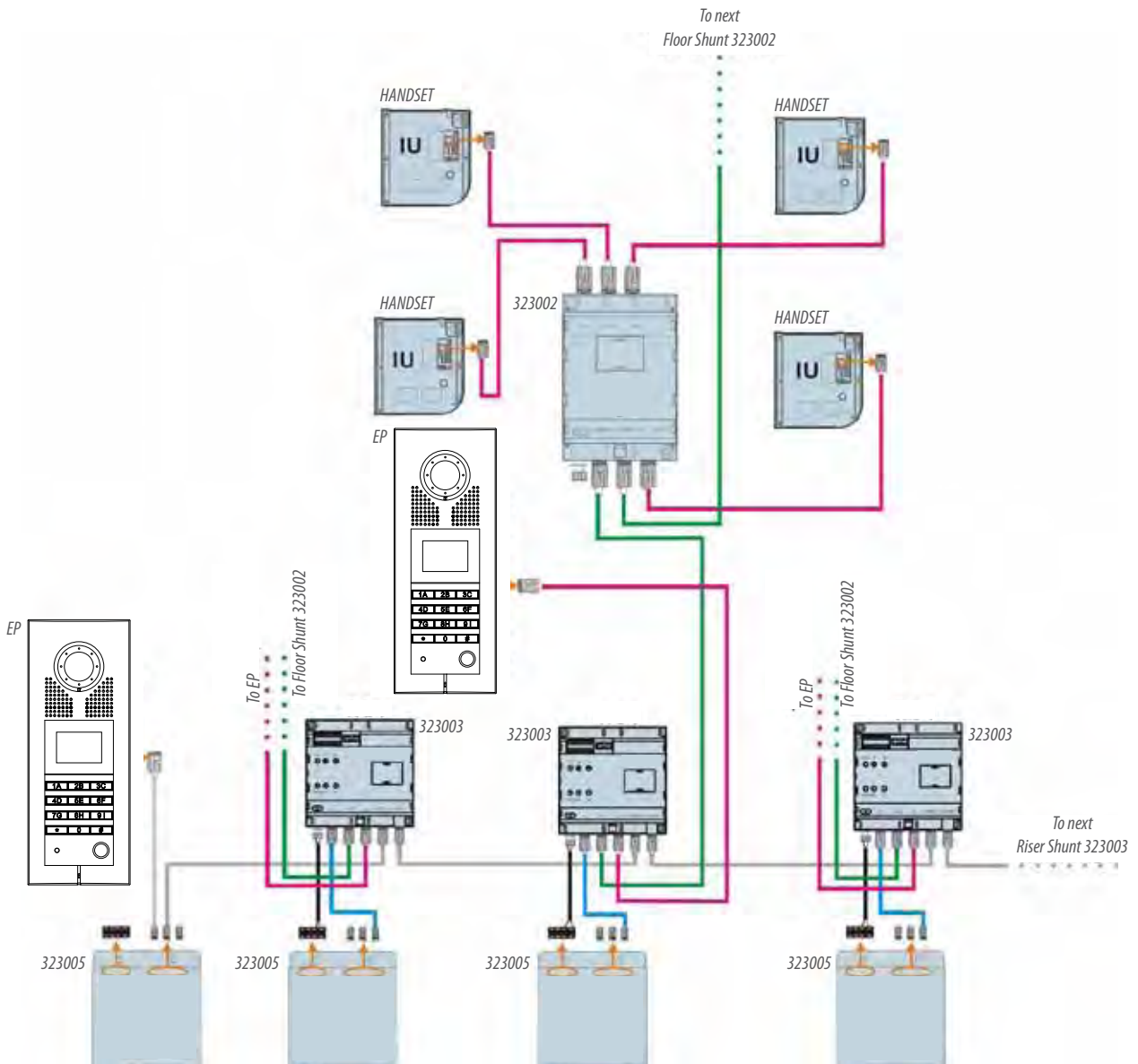


# Wiring diagrams

**DIAGRAM 5**  
**RISER CONNECTION WITH SEVERAL EPS (EXAMPLE 2)**

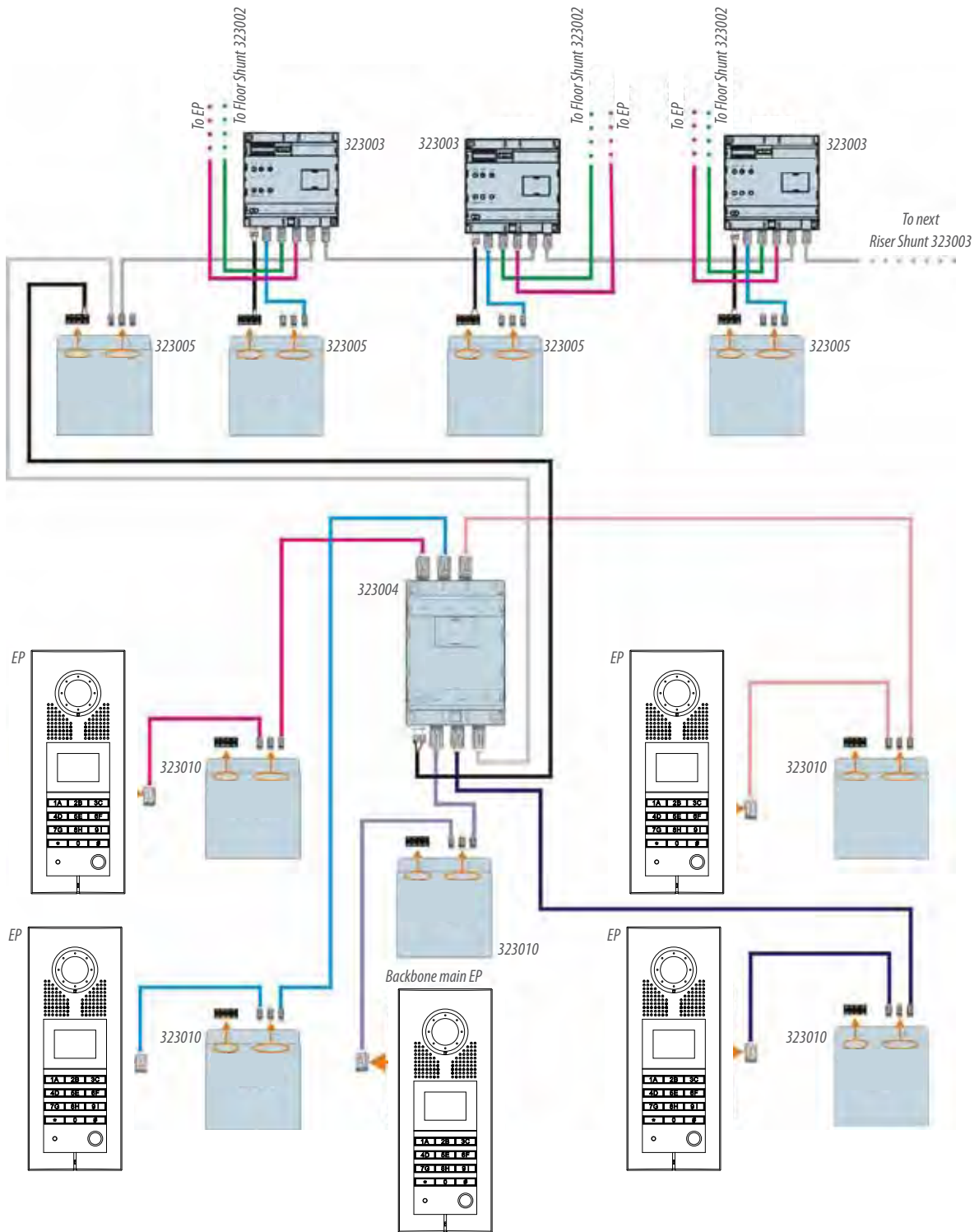


**DIAGRAM 6**  
**BACKBONE CONNECTION WITH 1 MAIN EP**



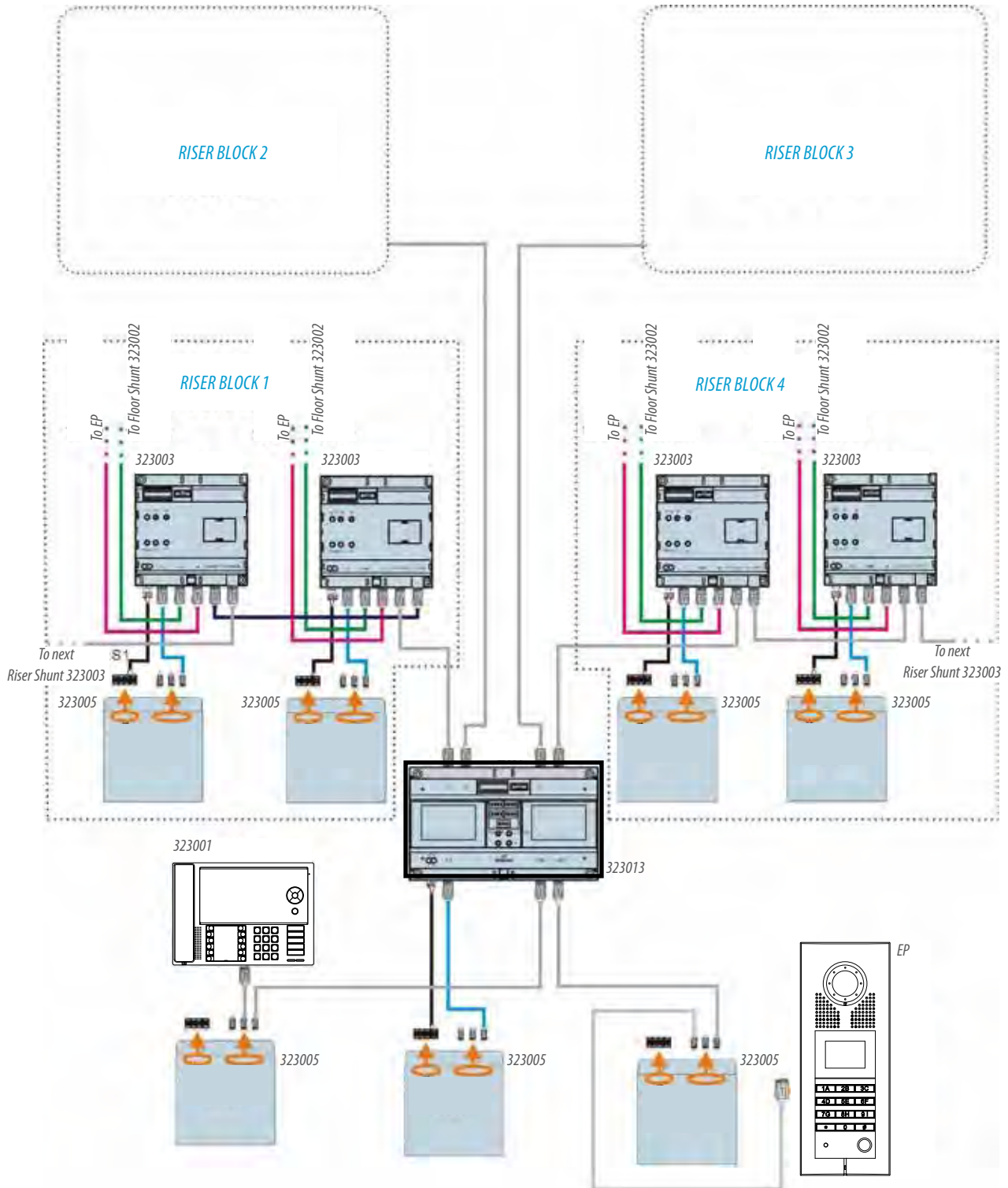


**DIAGRAM 8**  
**BACKBONE CONNECTION WITH SEVERAL MAIN EPS**

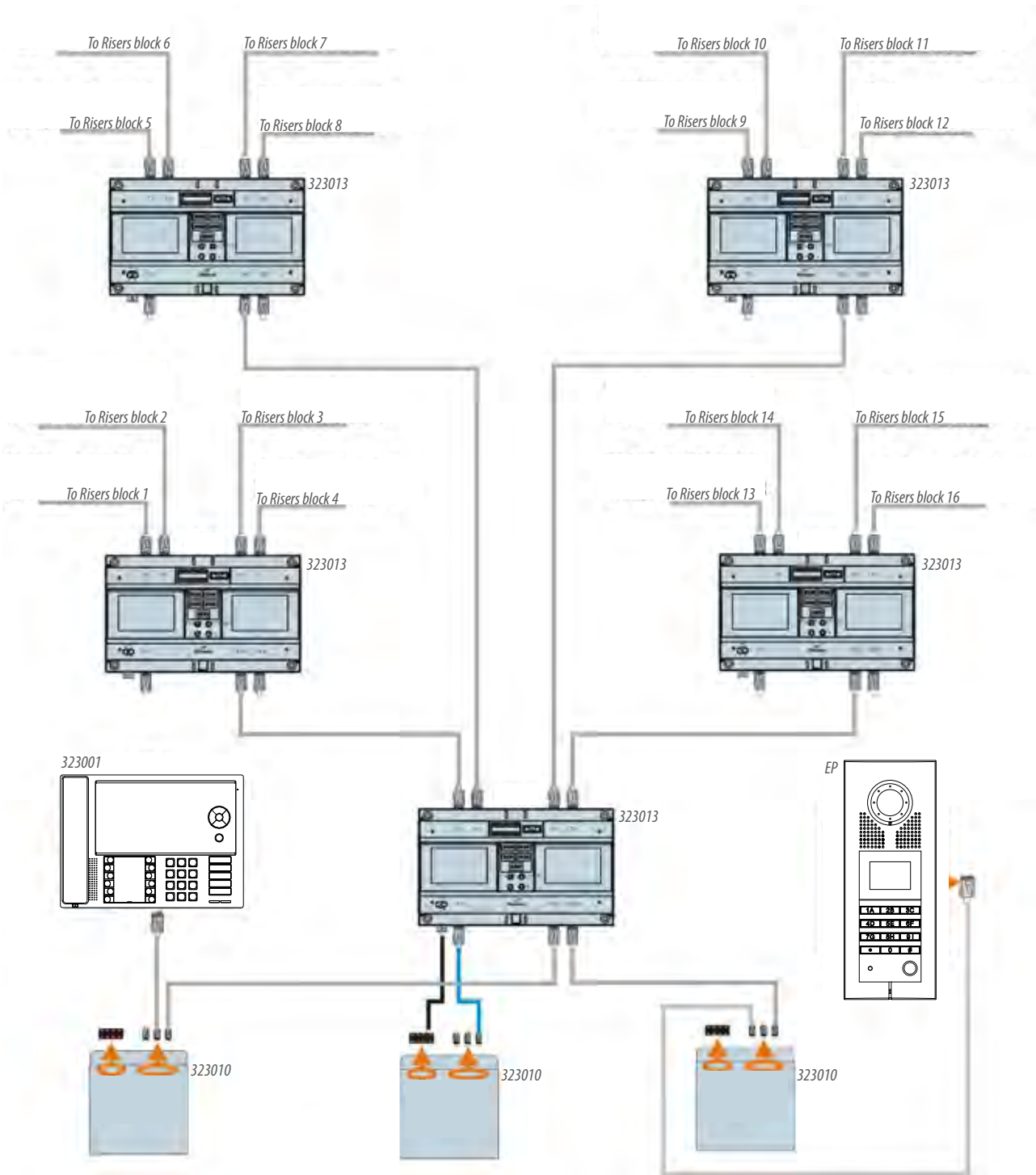


# Wiring diagrams

**DIAGRAM 9**  
**DISTRICT GENERATOR 323010 CONNECTION**

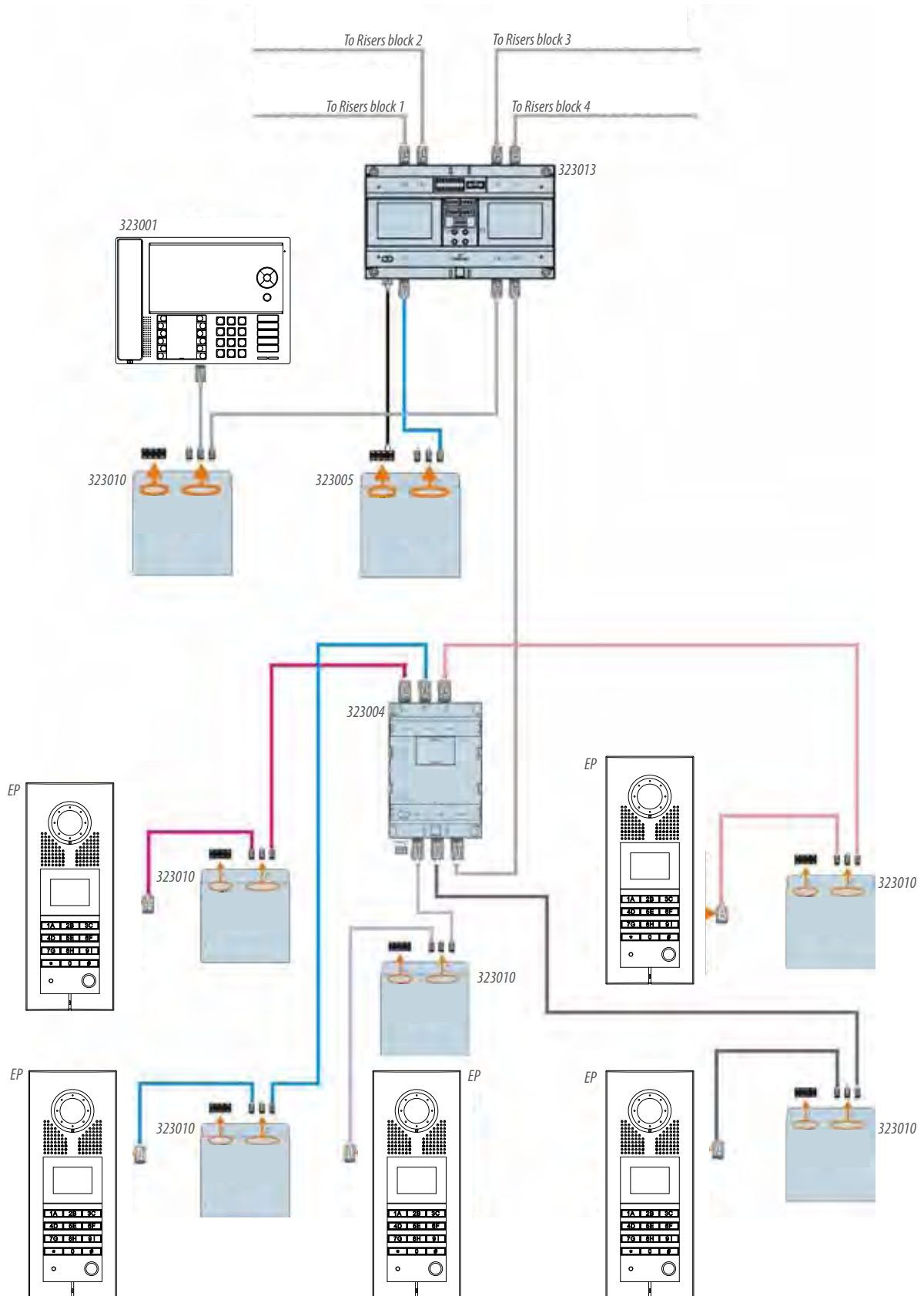


**DIAGRAM 10**  
**2 LAYER DISTRICT GENERATOR CONNECTIONS**

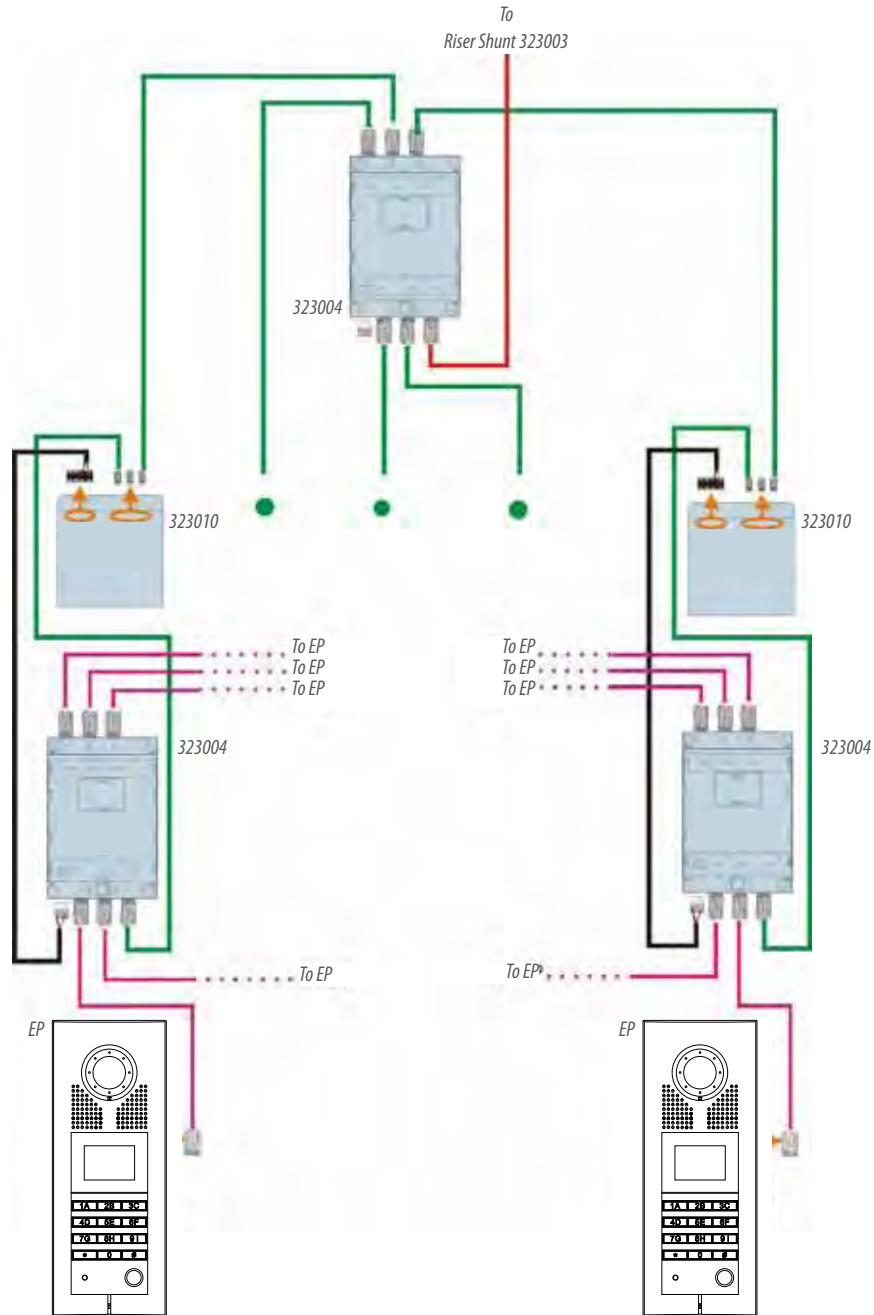


# Wiring diagrams

**DIAGRAM 11**  
**2 LAYER DISTRICT GENERATOR WITH SEVERAL EP CONNECTIONS**

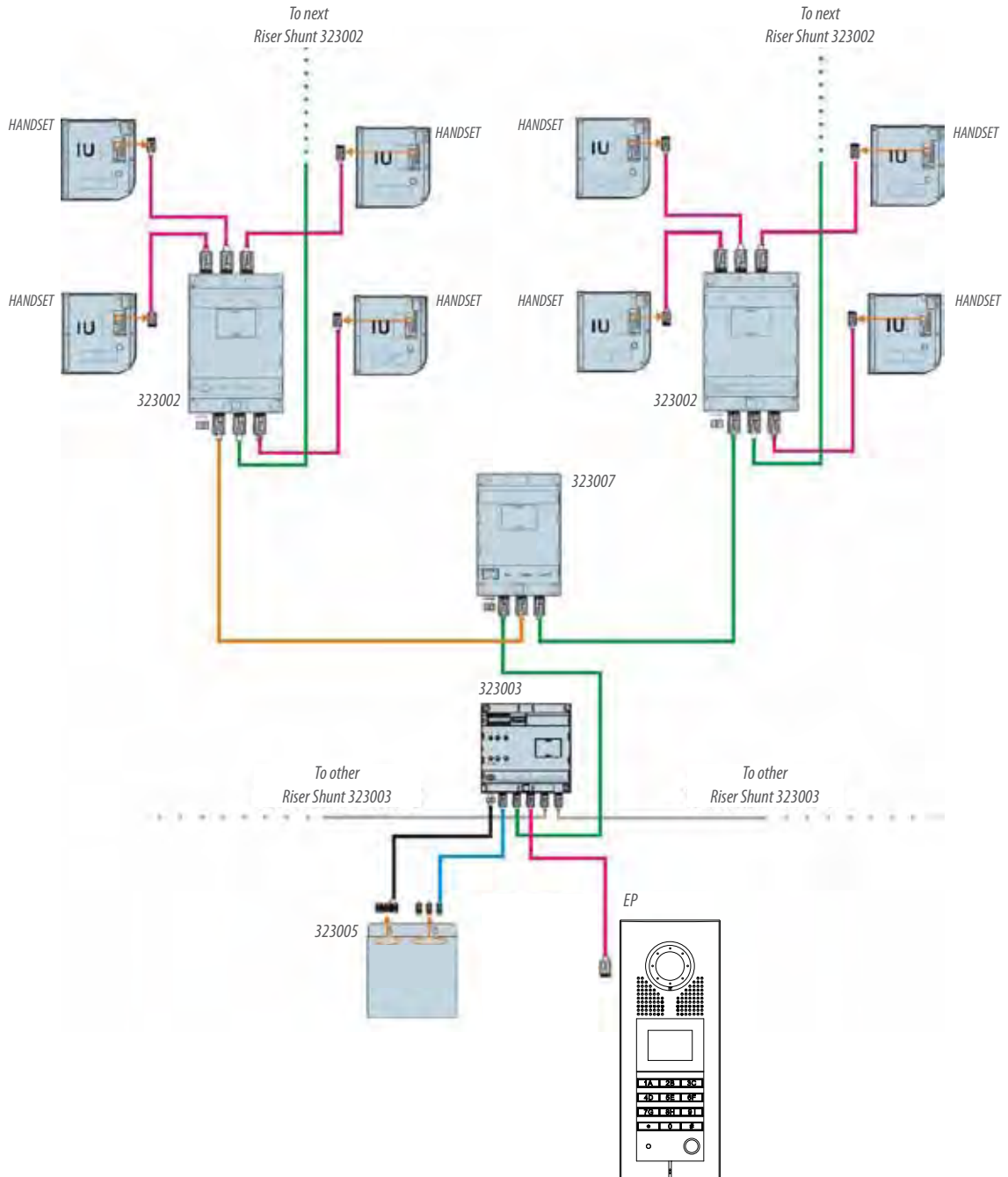


**DIAGRAM 12**  
**RISER WITH 323004 - VIDEO MIXER**

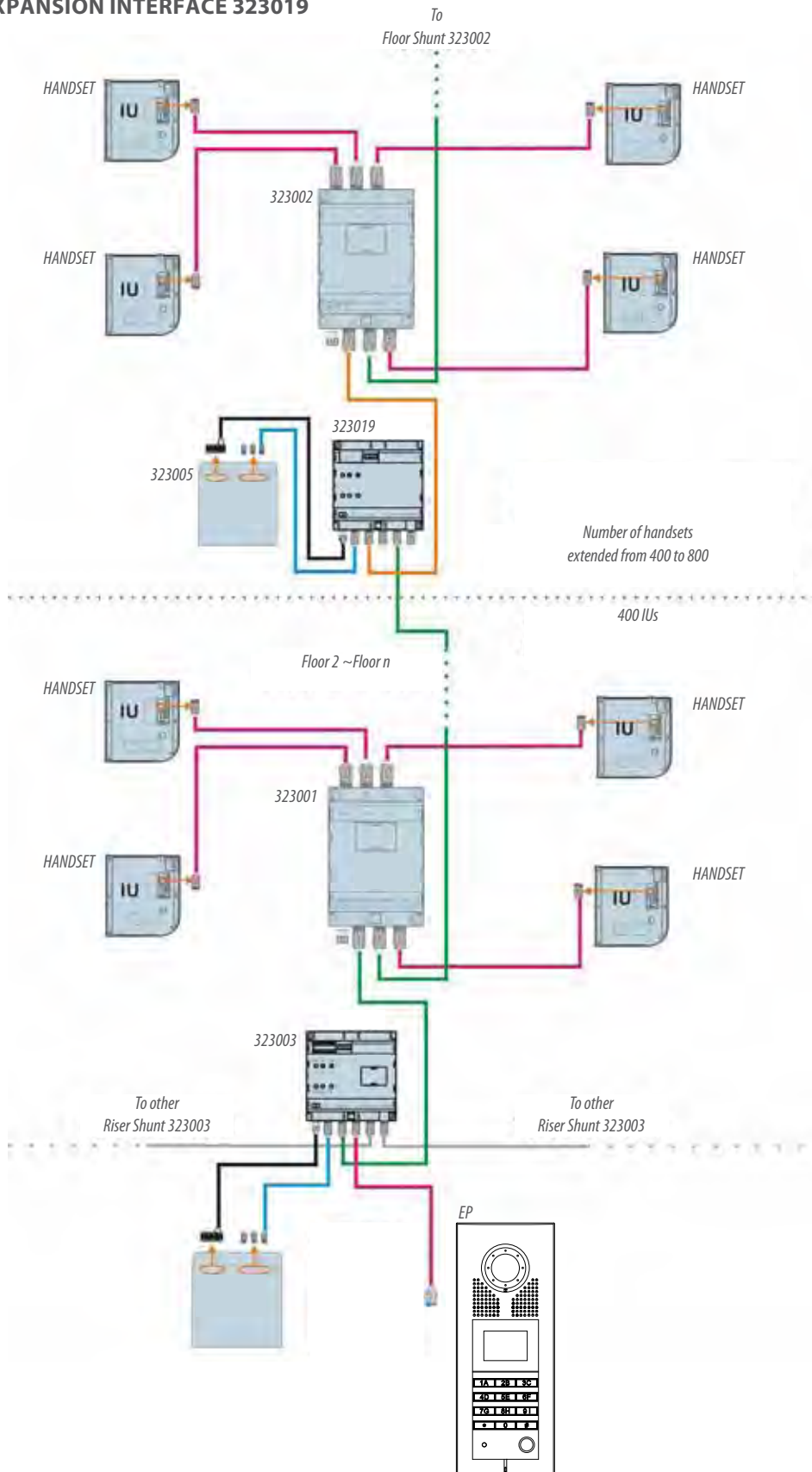


# Wiring diagrams

**DIAGRAM 13**  
**RISER WITH 2 BRANCHES VIDEO SPLITTER 323007**

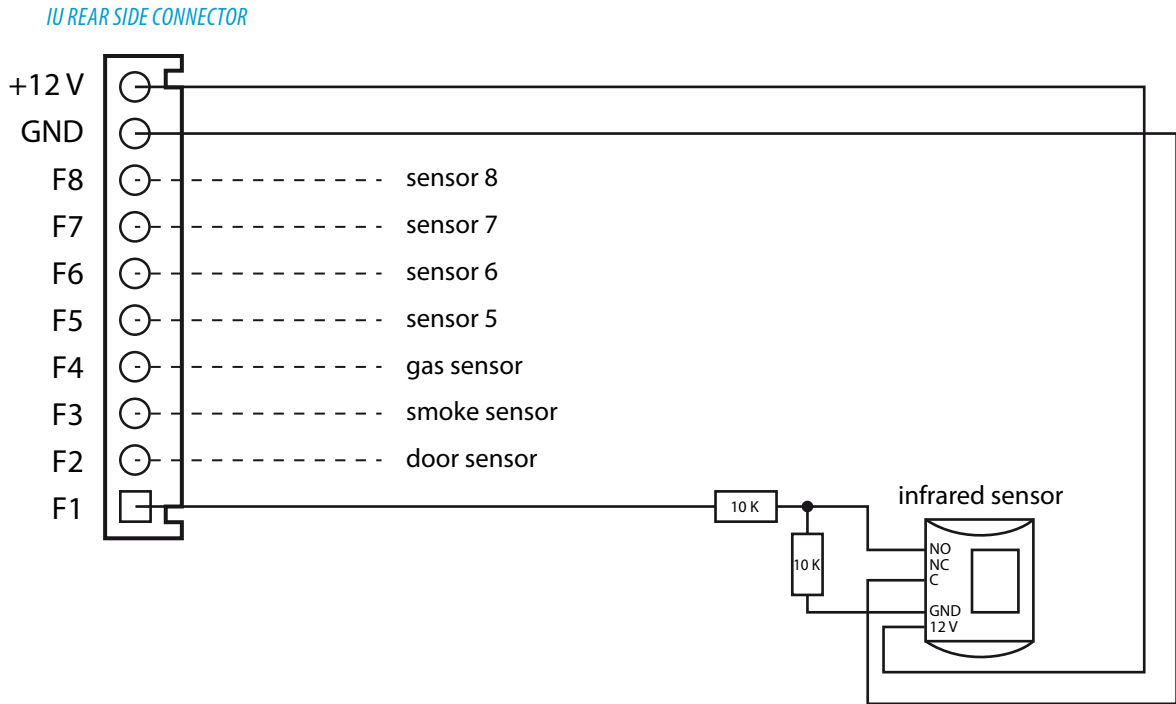


**DIAGRAM 14**  
**RISER WITH EXPANSION INTERFACE 323019**



# Wiring diagrams

**DIAGRAM 15**  
**INTERNAL UNIT ALARM SENSORS CONNECTIONS**

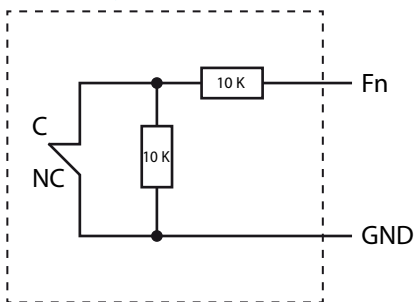


Note:

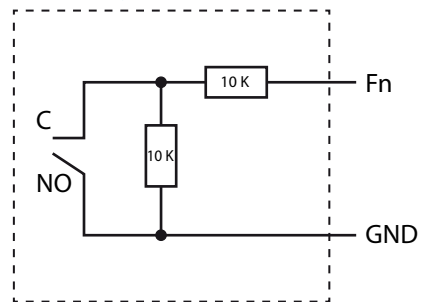
10 KΩ resistors are used to detect cable by cut or cable short circuited to GND. Resistors must be placed near the sensor. IU can afford sensor 12 Vdc - 300 mA max. type.

Connection way for NC and NO contacts:

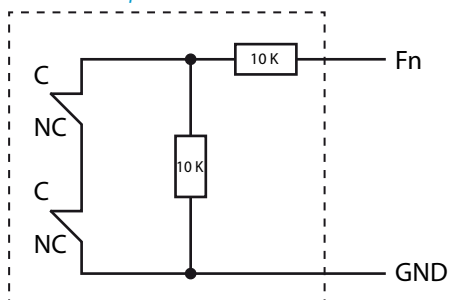
*NC mode - Single sensor*



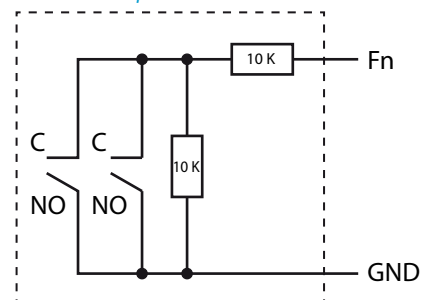
*NO mode - Single sensor*



*NC mode - Multiple sensors*



*NO mode - Multiple sensors*





**BTicino** SpA  
Via Messina, 38  
20154 Milano - Italia  
[www.bticino.com](http://www.bticino.com)